

PLAN
(For skew $\leq 30^\circ$)

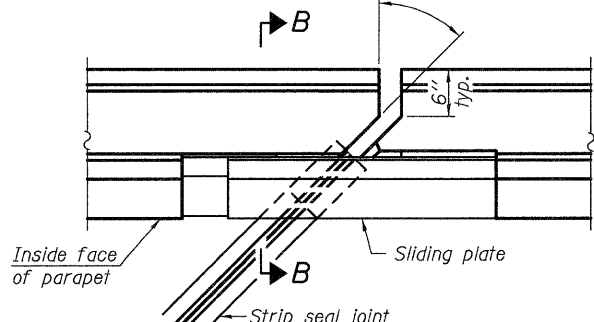

PLAN
(For skew $> 30^\circ$)
Showing point block

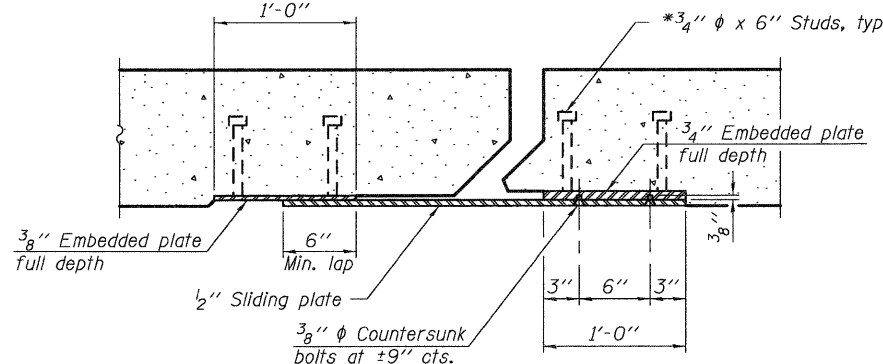

SECTION C-C

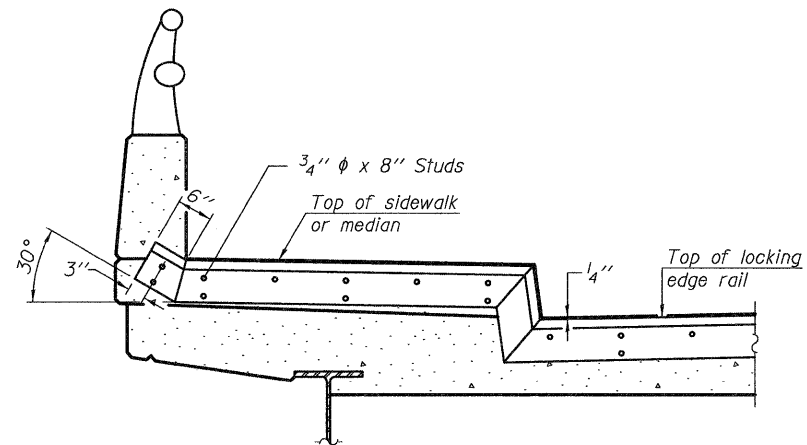

TYPICAL END TREATMENT AT SIDEWALK OR MEDIAN

Shorter plates with a single row of studs at 12" cts. may be necessary on medians which are shallower than 9". See manufacturer's recommendation.

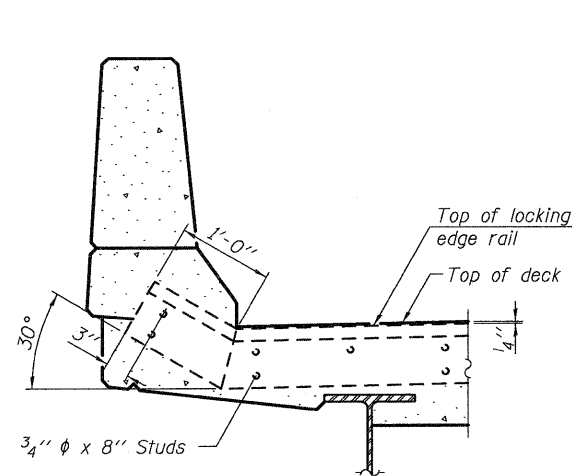

SECTION A-A

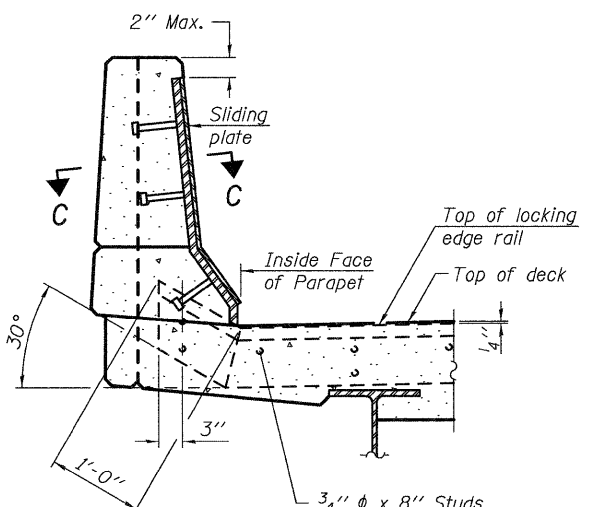

SECTION B-B

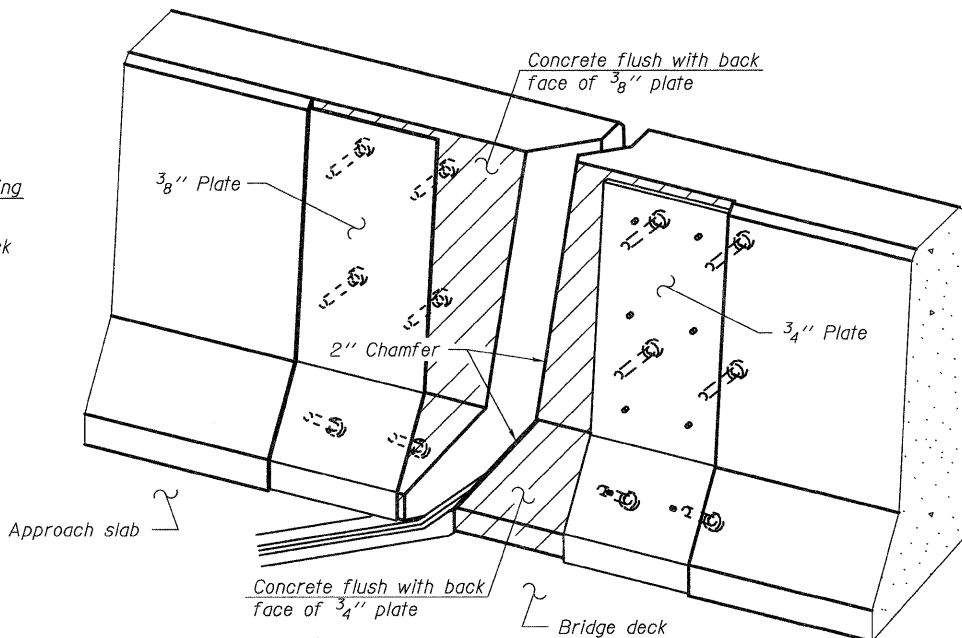

TRIMETRIC VIEW
(Showing back plates only)

Notes:
The strip seal shall be made continuous and shall have a minimum thickness of 1/4". The configuration of the strip seal shall match the configuration of the Locking Edge Rails. Open or "webbed" strip seal gland configurations are not permitted. The gland shall be sized for a maximum rated movement of 4 inches.

The Locking Edge Rails depicted are conceptual only, except for the minimum dimensions shown. The actual configuration of the Locking Edge Rails and matching strip seal may vary from manufacturer to manufacturer. Flanged edge rails will not be allowed. Locking Edge Rails may be spliced at slope discontinuities.

The manufacturer's recommended installation methods shall be followed.

The joint opening and deck dimensions detailed on the superstructure are based on a rolled rail expansion joint. If the Contractor elects to use the welded rail expansion joint, the opening and deck dimensions shall be modified according to the dimensions detailed on this sheet. Required modifications shall be made at no additional cost to the State.

All steel components shall be galvanized after fabrication according to Article 520.03 of the Standard Specifications.

Maximum space between rail segments at stage lines shall be 3/16", sealed with a suitable sealant.

Parapet plates and anchorage studs for skew $> 30^\circ$ included in the cost of Preformed Joint Strip Seal.

The inside of the Locking Edge Rail groove shall be free of weld residue.

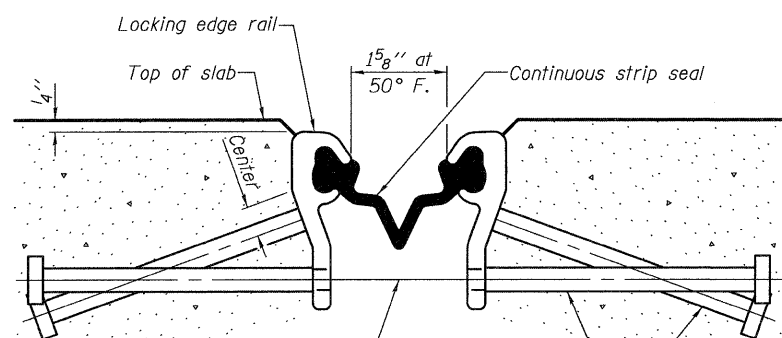

SECTION THRU STRIP SEAL JOINT FOR OVERLAY OVER DECK BEAMS

7/16" phi holes at 4'-0" cts. for 3/8" phi bolts. All bolts shall be burned, sawed, or chipped off flush with the plates after forms are removed, typ.

Place 1/2" phi x 6" granular or solid flux filled headed studs conforming to Article 1006.32 of the Std. Specs., automatically end welded at 1'-0" alt. cts.

* Omit weld at seal opening.

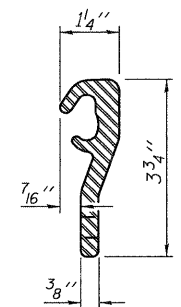

LOCKING EDGE RAIL

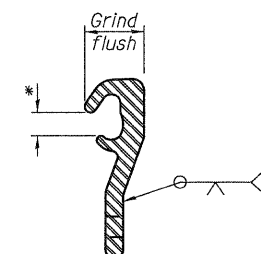

LOCKING EDGE RAIL SPLICE

BILL OF MATERIAL

Item	Unit	Total
Preformed Joint Strip Seal	Foot	146

DESIGNED - ADY	EXAMINED - <i>James F. Schell</i> ACTING ENGINEER OF STRUCTURAL SERVICES	DATE - MARCH 8, 2012
CHECKED - MKC	PASSED - <i>Carl Pomeroy</i> ACTING ENGINEER OF BRIDGES AND STRUCTURES	
DRAWN - Kyle M. Steffen		
CHECKED - ADY MKC		

STATE OF ILLINOIS
DEPARTMENT OF TRANSPORTATION

PREFORMED JOINT STRIP SEAL DETAILS
SN 101-0037 (NB) & 0038 (SB)

SHEET NO. 4 OF 6 SHEETS

F.A. RTE.	SECTION	COUNTY	TOTAL SHEETS	SHEET NO.
738	(5B-2)M	WINNEBAGO	22	14
CONTRACT NO. 64H23				
ILLINOIS FED. AID PROJECT				