

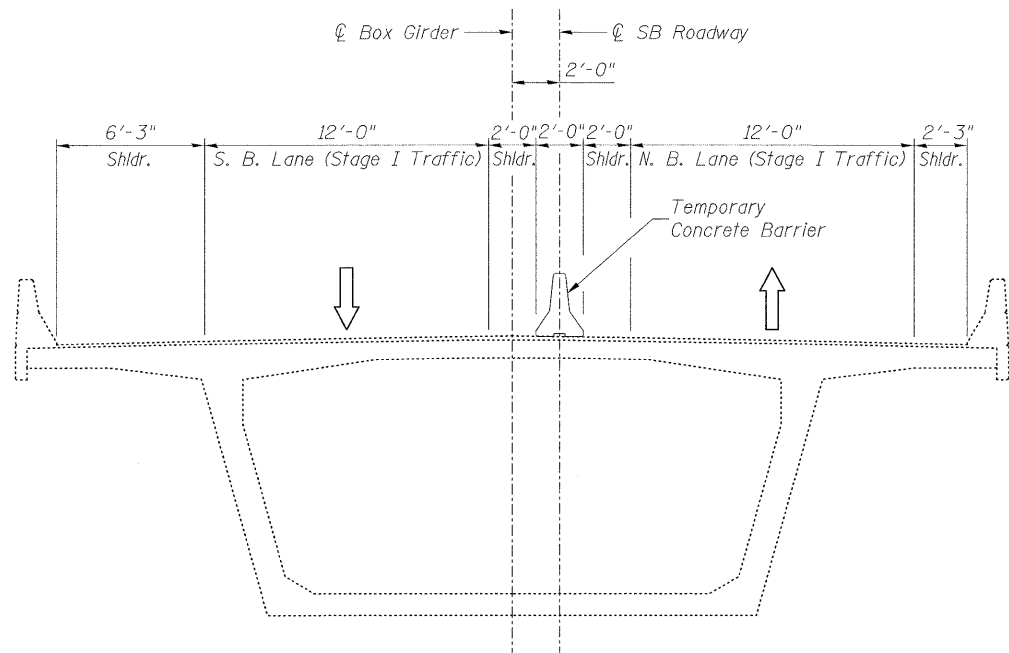

© Copyright Hanson Professional Services Inc. 2012

0:\work\101-0133\101-0133.dwg 05/14/12 5:00:14 PM
 05/14/12
 MTR00008

LAYOUT
 DRAWN
 REVIEWED



STAGE I - CONSTRUCTION
 (Looking North)

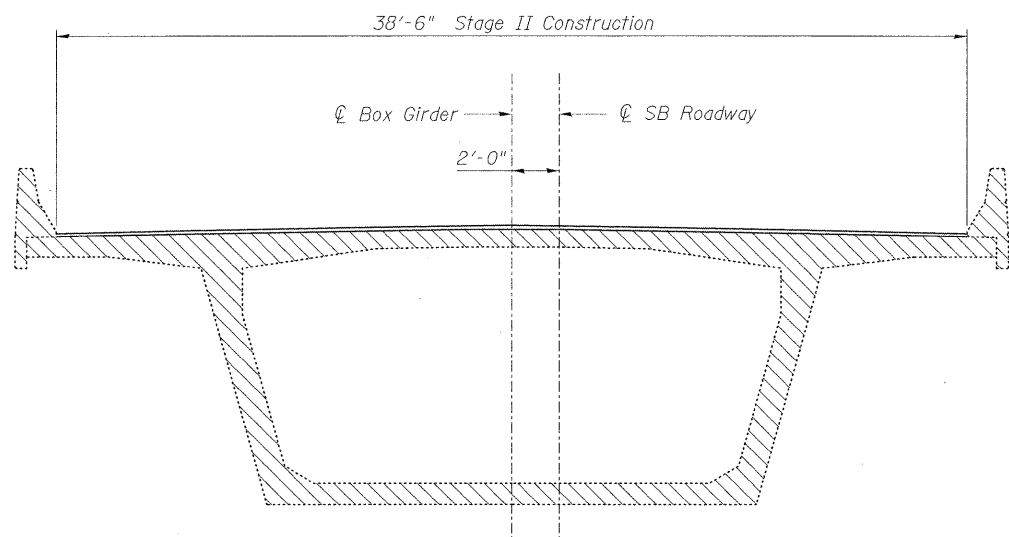
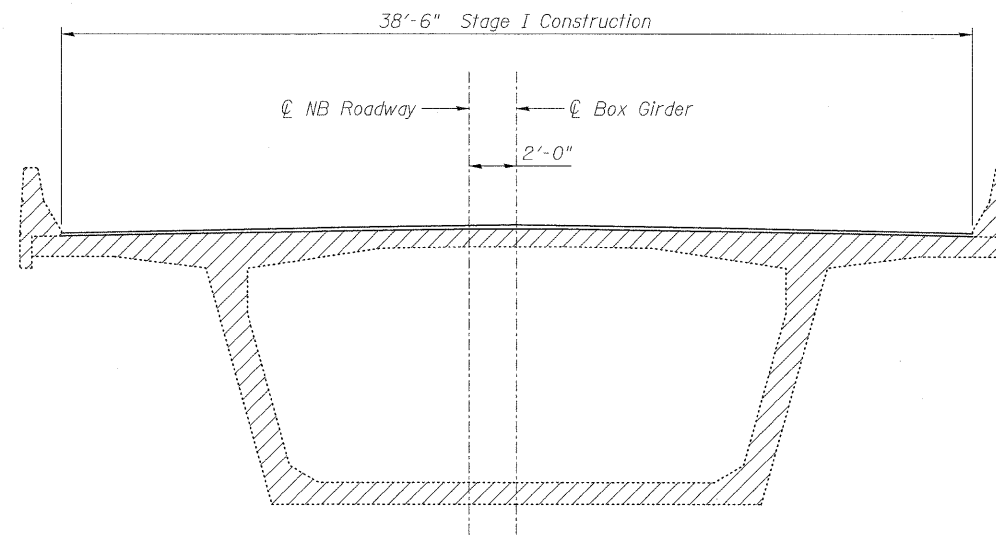

STAGE II - CONSTRUCTION
 (Looking North)

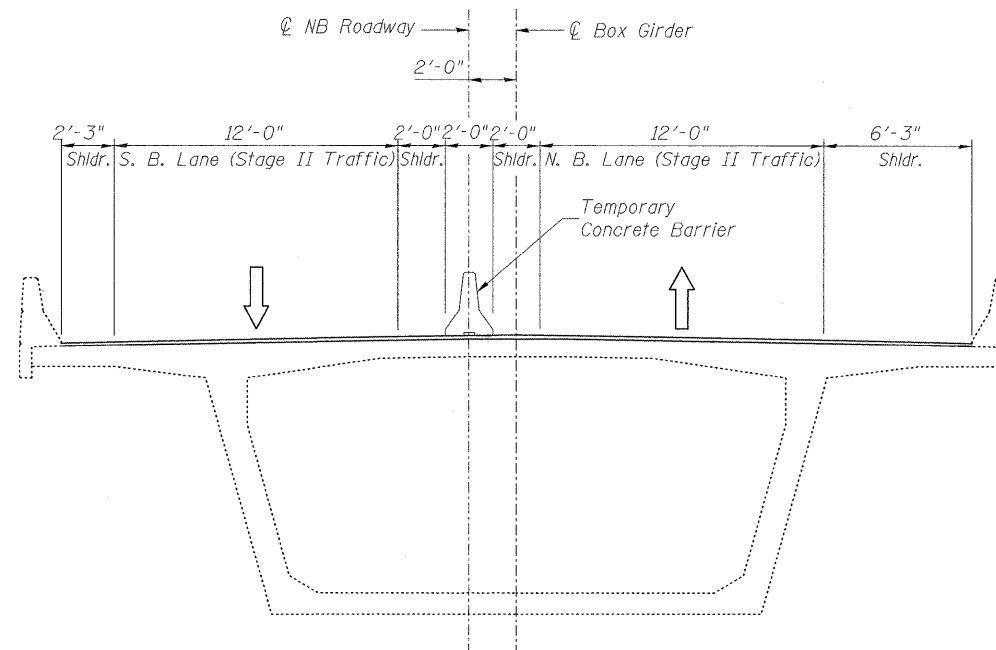

LEGEND:

Construction in this Stage

NOTES:
 Details for Temporary Concrete Barrier are on sheet 4 of 11.
 See Roadway Plans for Temporary Concrete Barrier Quantities.

FILE NAME =	USER NAME =	DESIGNED - MNM	REVISED
		CHECKED - TEH	REVISED
		DRAWN - Red (Parson's)	REVISED
		CHECKED - MNM	REVISED

**STATE OF ILLINOIS
 DEPARTMENT OF TRANSPORTATION**

**STAGE CONSTRUCTION DETAILS
 STRUCTURE NO. 101-0133 and 101-0134**

SHEET NO. 03 OF 11 SHEETS

F.A.J. RTE.	SECTION	COUNTY	TOTAL SHEETS	SHEET NO.
39	(201-1B)M-3	WINNEBAGO	38	30
CONTRACT NO. 64H72			ILLINOIS FED. AID PROJECT	