

ELEVATION

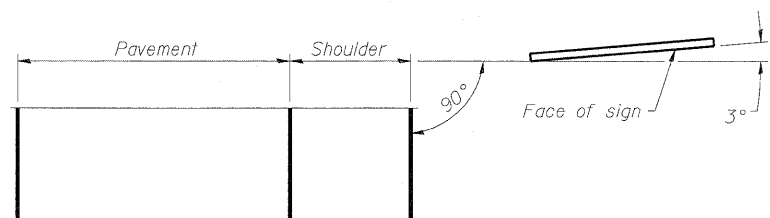

LOCATION SKETCH

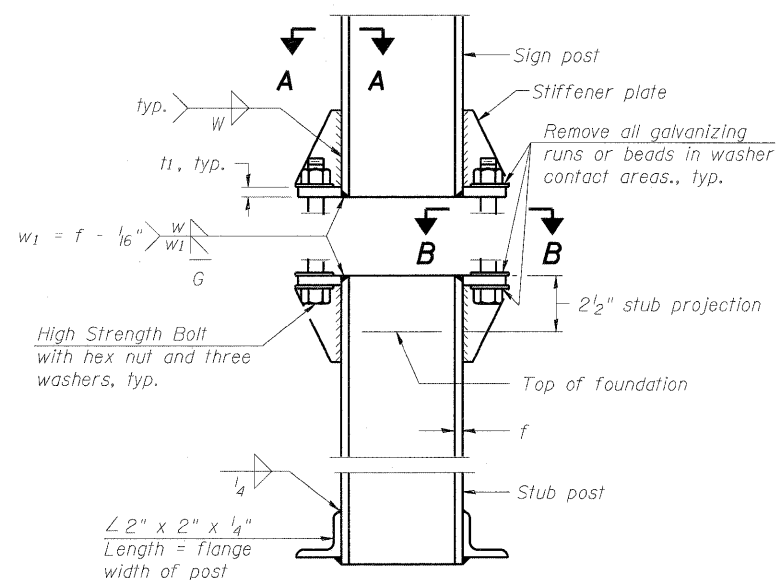

**ELEVATION
SIGN POST & STUB POST**

0.15W	2 spaces at 0.35W	0.15W	for 3 posts
0.125W	3 spaces at 0.25W	0.125W	for 4 posts
0.1W	4 spaces at 0.2W	0.1W	for 5 posts
0.1W	5 spaces at 0.16W	0.1W	for 6 posts
0.08W	6 spaces at 0.14W	0.08W	for 7 posts

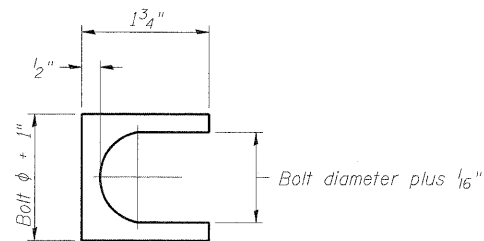

SHIM DETAIL

Furnish two 0.01" thick and two 0.03" thick stainless steel or brass (ASTM B36) shims per post.

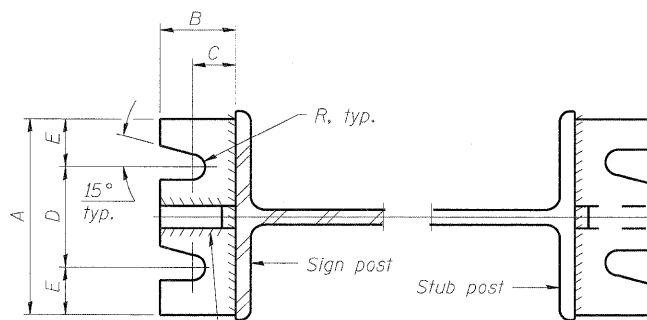

SECTION A-A

SECTION B-B

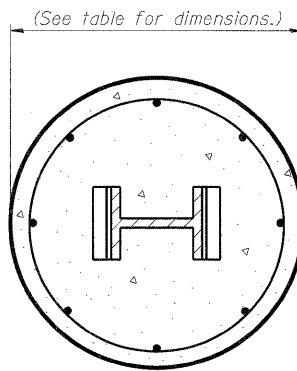

SECTION C-C

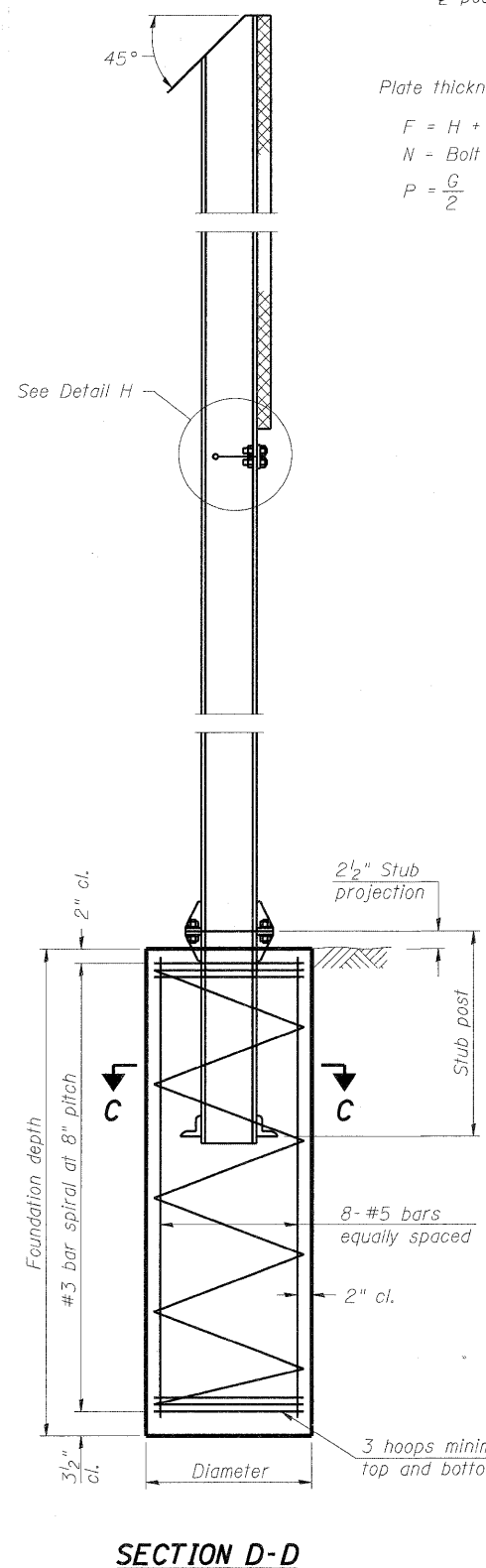

SECTION D-D

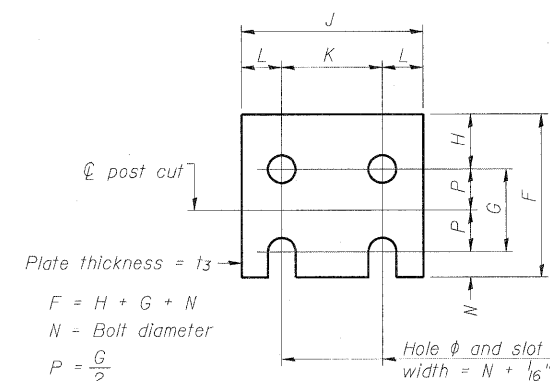

FUSE PLATE DETAIL

(Install with notches down.)

y = 3/16" maximum width of cut

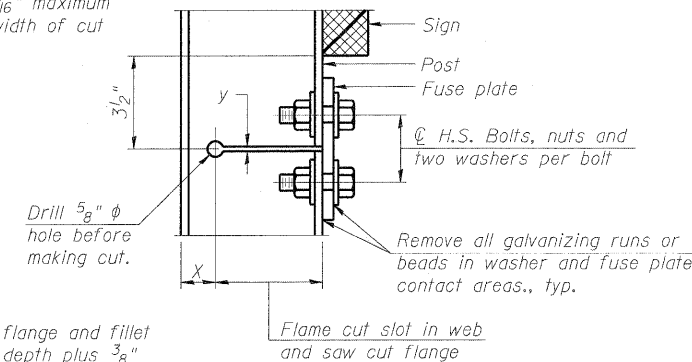

DETAIL H

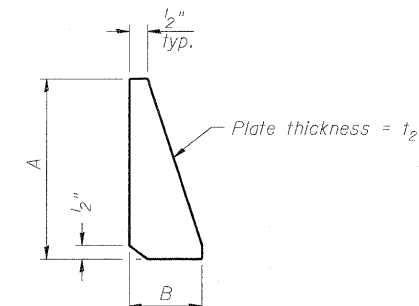

STIFFENER PLATE DETAIL

GENERAL NOTES

Posts shall be plumbed by using shims with post-to-stub post connection bolts snug tight only. Final tightening of all High Strength Bolts shall be in accordance with Article 727.05 and threads at the junction of the bolt and nut shall be burred or center punched to prevent the nut from loosening.

LOADING: 80 m.p.h. wind with 30% gust factor, normal to sign.

DESIGN STRESSES:
Structural steel - 20,000 p.s.i.
Reinforcing steel - 20,000 p.s.i.
Concrete - 1,400 p.s.i.
Footing soil pressure - 2,000 p.s.f.

After fabrication, the post, fuse plate and upper 6", min. of the stub post shall be hot-dip galvanized in accordance with AASHTO M111. All bolts, nuts and washers shall be hot-dip galvanized in accordance with AASHTO M232.

Work this sheet with Base Sheet BAW-A-2.

BAW-A-1

7-1-10

(Sheet 1 of 2)

FILE NAME =	USER NAME =	DESIGNED - PMK	REVISED -	STATE OF ILLINOIS DEPARTMENT OF TRANSPORTATION	BREAK-AWAY WIDE FLANGE STEEL SIGN POST DETAILS	F.A.I. RTE.	SECTION	COUNTY	TOTAL SHEETS	SHEET NO.
		CHECKED - MPW	REVISED -			82-1-RIA, 82-1-R(B)	ST. CLAIR	629	427	
		DRAWN - PMK	REVISED -			CONTRACT NO. 76C52				
		CHECKED - MPW	REVISED -			ILLINOIS FED. AID PROJECT				