

PLAN
(For skews $\leq 30^\circ$)

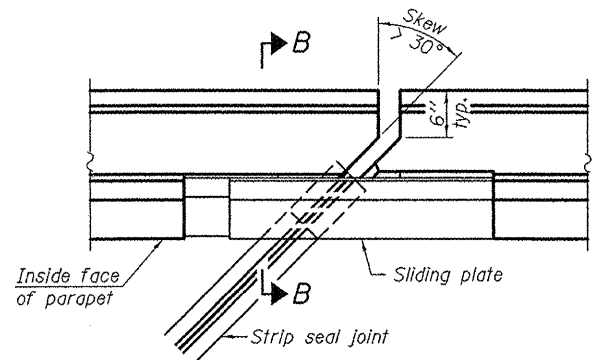

PLAN
(For skews $> 30^\circ$)
Showing point block

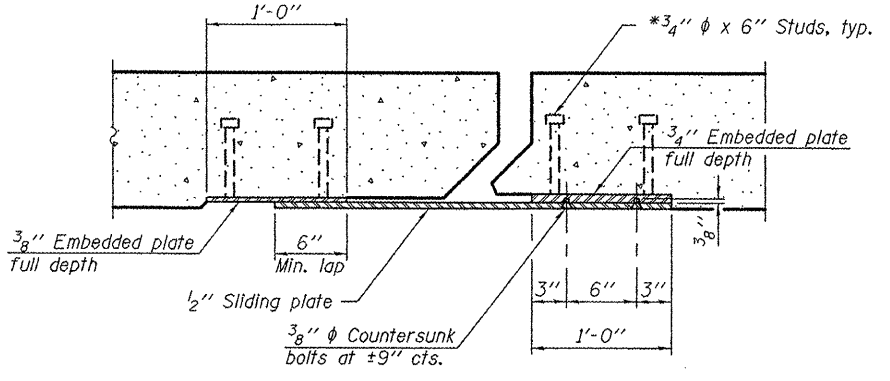

SECTION C-C

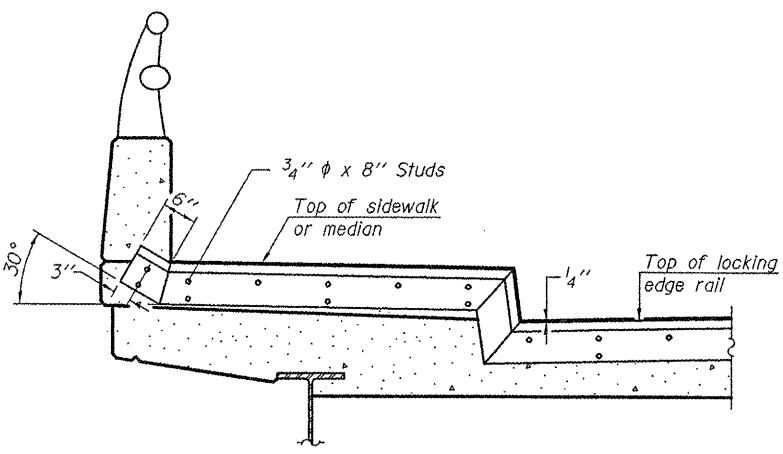

TYPICAL END TREATMENT AT SIDEWALK OR MEDIAN

Shorter plates with a single row of studs at 12" cts. may be necessary on medians which are shallower than 9". See manufacturer's recommendation.

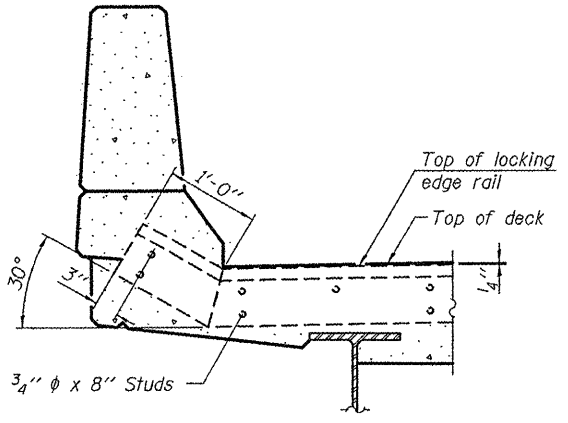

SECTION A-A

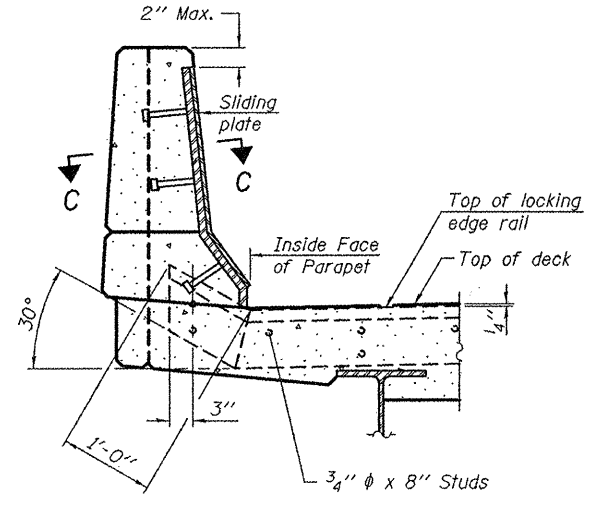

SECTION B-B

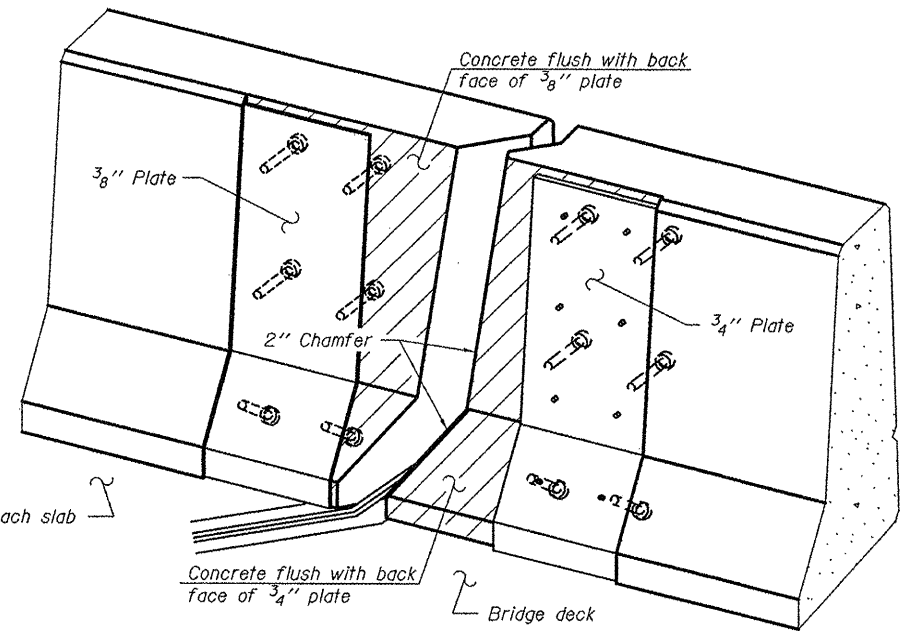

TRIMETRIC VIEW
(Showing back plates only)

Notes:

The strip seal shall be made continuous and shall have a minimum thickness of 1/4". The configuration of the strip seal shall match the configuration of the Locking Edge Rails. Open or "webbed" strip seal gland configurations are not permitted. The gland shall be sized for a maximum rated movement of 4 inches.

The Locking Edge Rails depicted are conceptual only, except for the minimum dimensions shown. The actual configuration of the Locking Edge Rails and matching strip seal may vary from manufacturer to manufacturer. Flanged edge rails will not be allowed. Locking Edge Rails may be spliced at slope discontinuities.

The manufacturer's recommended installation methods shall be followed.

The joint opening and deck dimensions detailed on the superstructure are based on a rolled rail expansion joint. If the Contractor elects to use the welded rail expansion joint, the opening and deck dimensions shall be modified according to the dimensions detailed on this sheet. Required modifications shall be made at no additional cost to the State.

All steel components shall be galvanized after fabrication according to Article 520.03 of the Standard Specifications.

Maximum space between rail segments at stage lines shall be 3/16", sealed with a suitable sealant.

Parapet plates and anchorage studs for skews $> 30^\circ$ included in the cost of Preformed Joint Strip Seal.

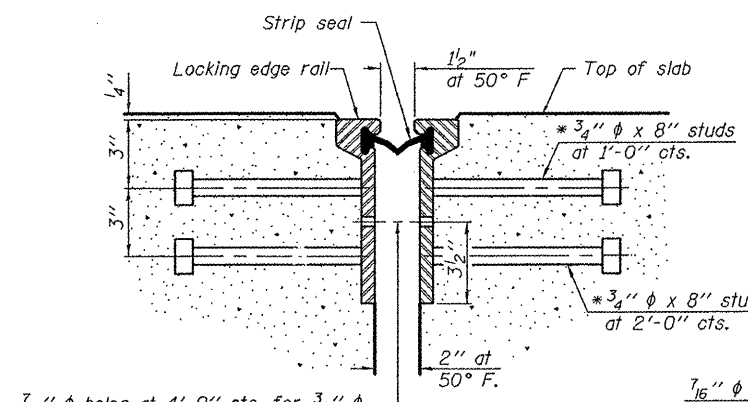

SECTION THRU ROLLED RAIL JOINT

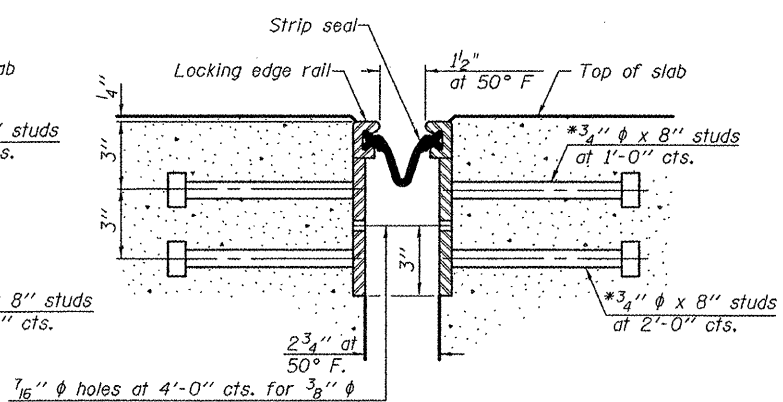

SECTION THRU WELDED RAIL JOINT

7/16" phi holes at 4'-0" cts. for 3/8" phi bolts. All bolts shall be burned, sawed, or chipped off flush with the plates after forms are removed, typ.

7/16" phi holes at 4'-0" cts. for 3/8" phi bolts. All bolts shall be burned, sawed, or chipped off flush with the plates after forms are removed, typ.

* Granular or solid flux filled headed studs conforming to Article 1006.32 of the Std. Specs., automatically end welded.

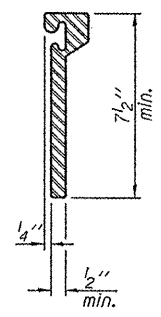

ROLLED EXTRUDED RAIL

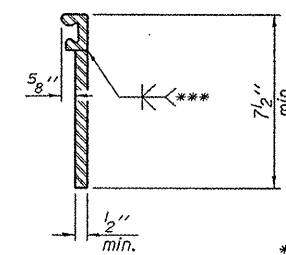

WELDED RAIL

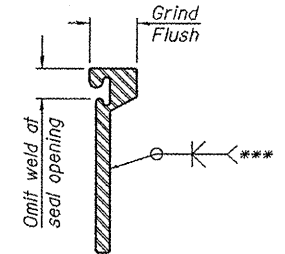

LOCKING EDGE RAIL SPLICE

The inside of the locking edge rail groove shall be free of weld residue. Rolled rail shown, welded rail similar.

*** Back gouge not required if complete joint penetration is verified by mock-up.

LOCKING EDGE RAILS

BILL OF MATERIAL

Item	Unit	Total
Preformed Joint Strip Seal	Foot	89.0

EJ-SSJ

7-1-10

DESIGNED - J. Uehle	EXAMINED	DATE - April 27, 2012
CHECKED - B. Williams	ENGINEER OF STRUCTURAL SERVICES	
DRAWN - J. Uehle	PASSED	REVISED
CHECKED - B. Williams	ENGINEER OF BRIDGES AND STRUCTURES	REVISED

STATE OF ILLINOIS DEPARTMENT OF TRANSPORTATION

PREFORMED JOINT STRIP SEAL SN 079-0007

SHEET NO. 3 OF 8 SHEETS

F.A.P. RTE. 861	SECTION 110BR-1	COUNTY RANDOLPH	TOTAL SHEETS 14	SHEET NO. 9
				CONTRACT NO. 76F07
ILLINOIS FED. AID PROJECT				