

- NOTES**
- Contractor may alternatively use standard aluminum drive-fit cap to close end.  $\frac{1}{2}$ "  $\phi$  drain hole in end plate/drive-fit cap. (Typ. at ends of all chords)
  - $5\frac{1}{2}$ " end dimension may vary by  $\pm 1$ " to provide uniform panel spacing (P).
  - Panel spacing (P) shall be uniform for entire truss and between 4'-0" and 5'-0" for Type I-A or 4'-0" and 5'-6" for Types II-A and III-A.
  - Vertical Diagonals in front and back face shall alternate.
  - Hidden lines show wind bracing alternates direction between planes of top and bottom chords.
  - All diagonals shall be detailed for minimum offset from the panel point based on the following: Offset shall be such as to provide a  $\frac{3}{4}$ " minimum to  $\frac{1}{2}$ " maximum clearance between any diagonal and any horizontal or vertical member, and to provide clearance for U-bolt connections of signs or walkway brackets.

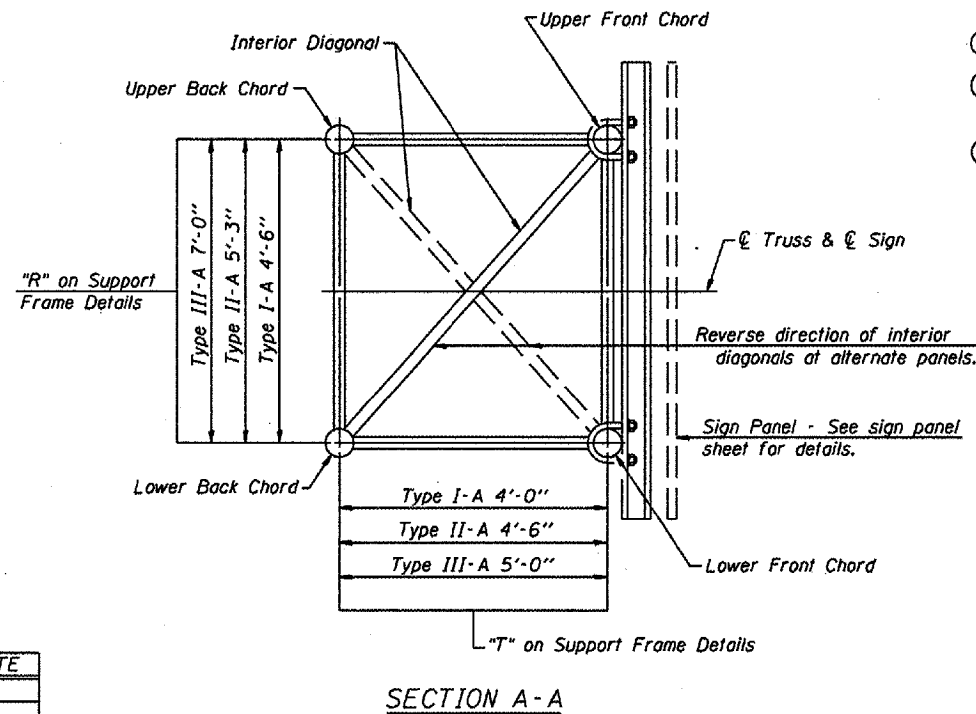
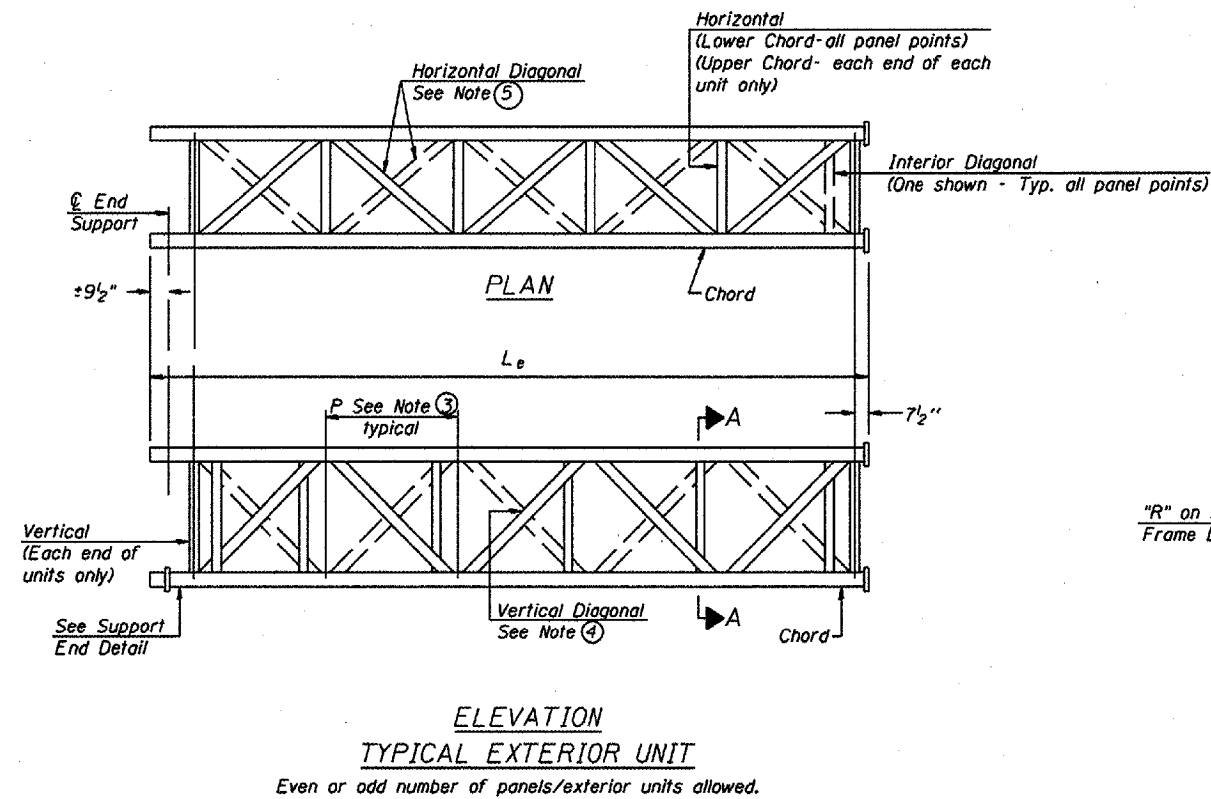

OVERHEAD SIGN STRUCTURES  
ALUMINUM TRUSS DETAILS  
FOR TRUSS TYPES I-A, II-A and III-A

District 2  
Overhead Sign  
Structure Replacement

DESIGNED -	20
CHECKED -	EXAMINED
DRAWN -	PASSED
CHECKED -	

ENGINEER OF BRIDGE DESIGN  
ENGINEER OF BRIDGES AND STRUCTURES

NUMBER	REVISION	DATE