

TRUSS UNIT TABLE

Structure Number	Station	Design Truss Type	Exterior Units (2)		Interior Unit		Upper & Lower Chord		Verticals; Horizontals; Vertical, Horizontal, and Interior Diagonals		Camber at Midspan	Splicing Flange								
			No. Panels per Unit	Unit Lgth.(L _u)	Panel Lgth.(P)	No. Req'd.	No. Panels per Unit	Unit Lgth.(L _i)	Panel Lgth.(P)	O.D.		Wall	O.D.	Wall	Bolts		Weld Sizes		A	B
															No./Splice	Dia.	W	W _i		
2S0371080L011.4	1026 + 40	I-A	5	25'-10"	4'-9 1/2"			5"	1/4"	2 1/2"	1/4"	1 1/4"	6	7/8"	5/16"	1/4"	8 3/4"	11 3/4"		
2S0501080R073.4	486 + 00	I-A	6	28'-9"	4'-5 3/4"	1	6	28'-1 1/2"	4'-5 3/4"	5"	5/16"	2 1/2"	5/16"	2 1/2"	6	7/8"	5/16"	1/4"	8 3/4"	11 3/4"

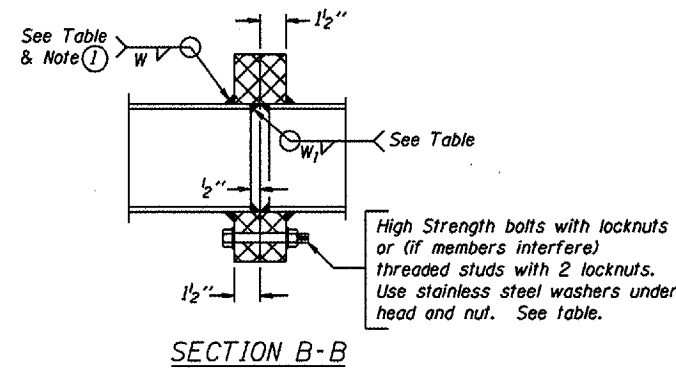

① Splicing Flanges shall be attached to each truss unit with the truss shop assembled to camber shown. Truss units shall be in proper alignment and flange surfaces shall be shop bolted into full contact before welding. Sufficient external welds or tacks shall be made to secure flanges until remaining welds are made after disassembly. Adjacent flanges shall be "match marked" to insure proper field assembly.

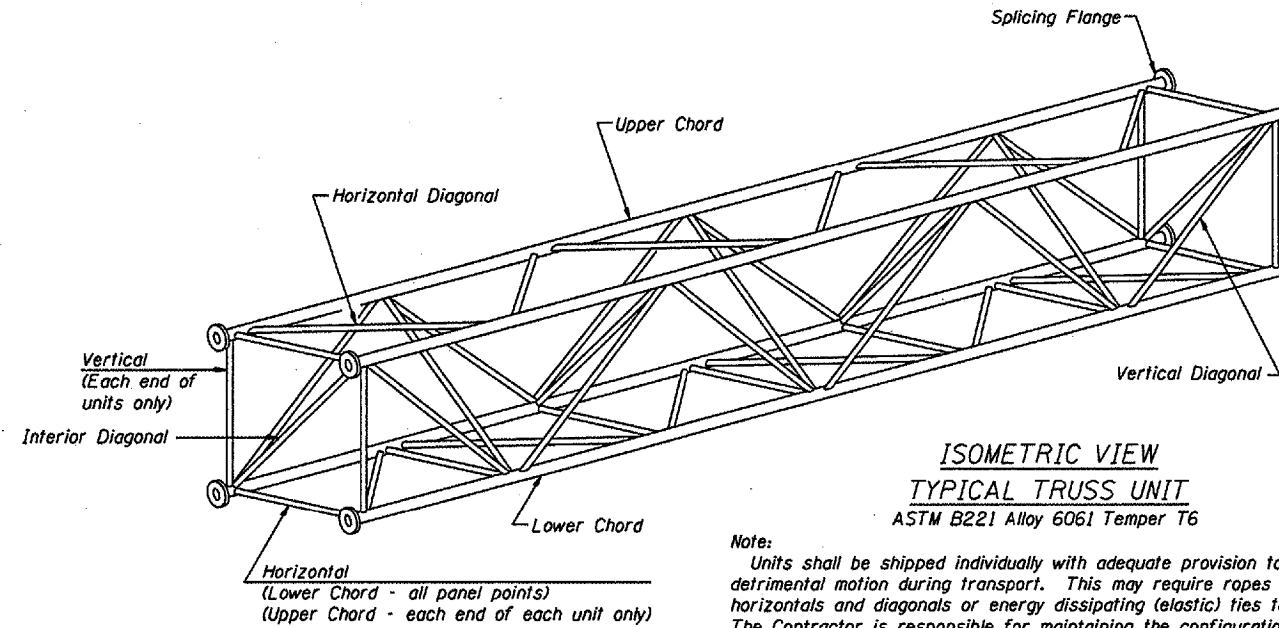

Note:
Units shall be shipped individually with adequate provision to prevent detrimental motion during transport. This may require ropes between horizontals and diagonals or energy dissipating (elastic) ties to the vehicle. The Contractor is responsible for maintaining the configuration and protection of the units.

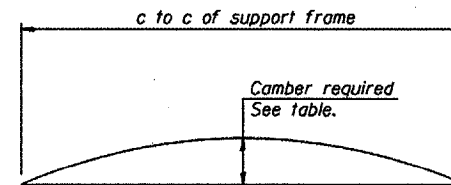

CAMBER DIAGRAM

Camber curve shown is theoretical. Actual camber attained by slope changes at splices between units.

CAMBER ATTAINMENT EXAMPLES:

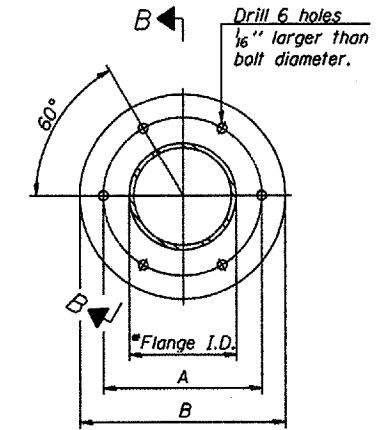
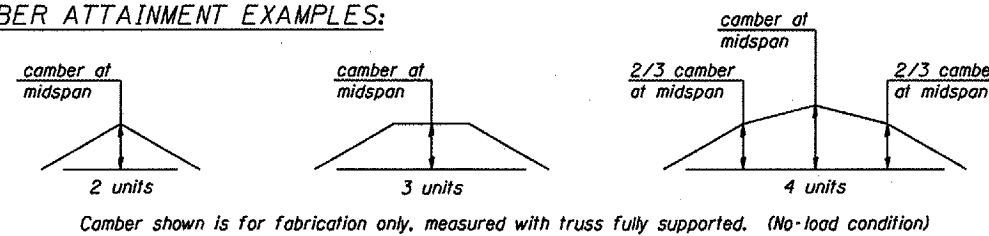

TRUSS TYPES I-A, II-A, & III-A

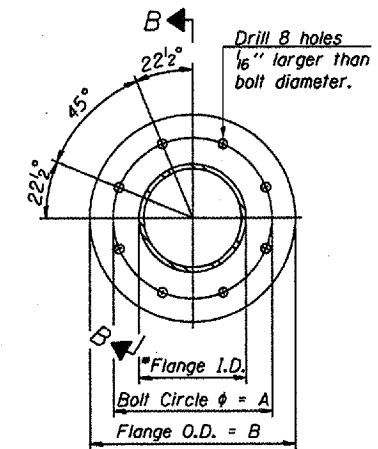

TRUSS TYPES II-A & III-A

SPLICING FLANGES

ASTM B221, Alloy 6061-T6
or ASTM B209, Alloy 6061-T651
*To fit O.D. of Chord with maximum gap of 1/16".

NUMBER	REVISION	DATE

DESIGNED -	20
CHECKED -	EXAMINED
DRAWN -	PASSED
CHECKED -	ENGINEER OF BRIDGES AND STRUCTURES

OS4-A-2

1-7-05

OVERHEAD SIGN STRUCTURES
ALUMINUM TRUSS DETAILS
FOR TRUSS TYPES I-A, II-A and III-A

District 2
Overhead Sign
Structure Replacement