

DETAIL B

Ribs shall be cut to fit slope of pipe.

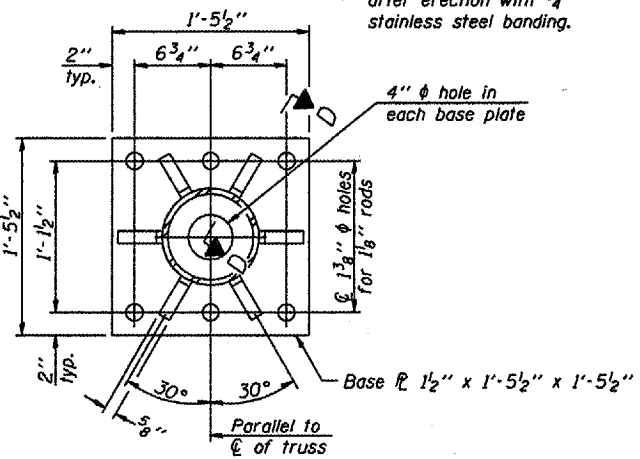

SECTION B-B

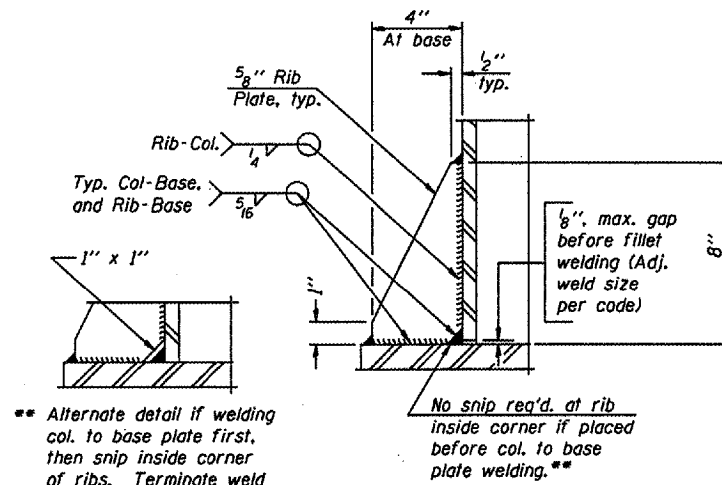

SECTION D-D

** Alternate detail if welding col. to base plate first, then snip inside corner of ribs. Terminate weld on rib 1/4" from snip.

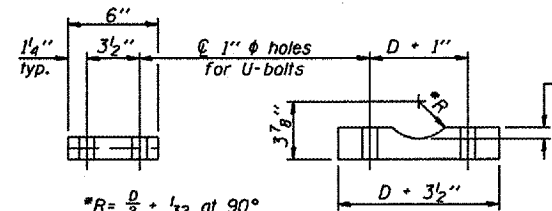

SADDLE SHIM DETAIL

ASTM B26 Alloy 356-F
or
ASTM B209 Alloy 6061-T651
(4 required per sign truss)

Truss Chord Nominal Dia.	a
5"	3/4"
5 1/2"	13/16"
6"	7/8"
6 1/2"	15/16"

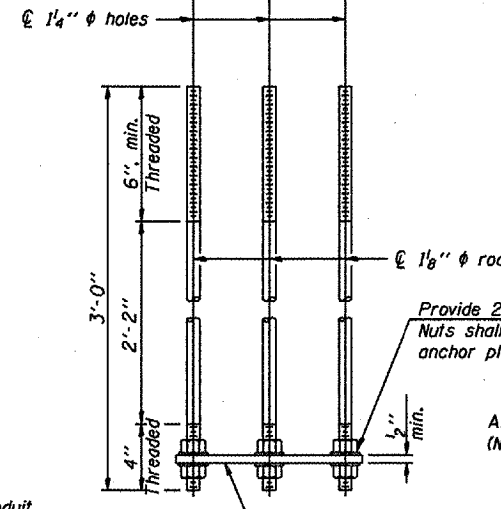
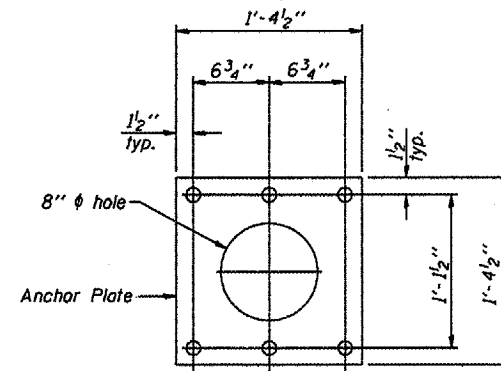

ANCHOR ROD DETAIL
Spread Footing Foundation

All Thread = NC (National Coarse)

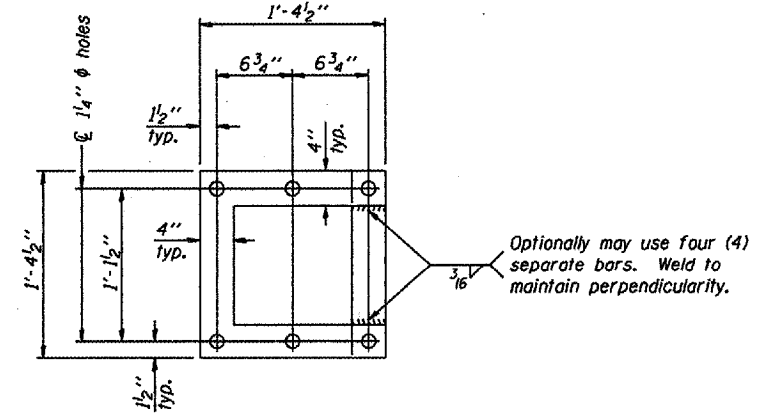

POSITIONING PLATE(S)

At each location, provide 1/4" thick positioning plate(s) and six (6) additional nuts to be used with leveling nuts to maintain anchor bolts position during concrete placement.

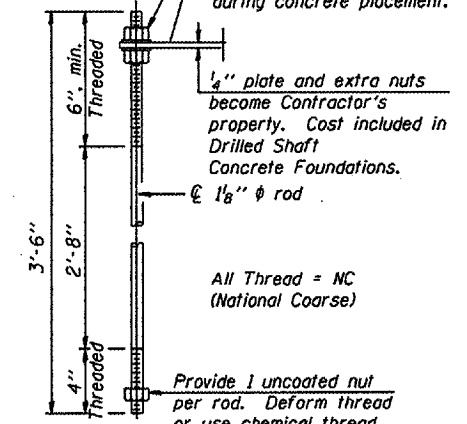

ANCHOR ROD DETAIL
Drilled Shaft Foundation

Anchor rods shall conform to AASHTO M314 Grade 36 or 55 and meet Charpy V-Notch (CVN) energy of 15 lb.-ft. at 40° F. Galvanize upper 12" per AASHTO M232. No welding shall be permitted on rods.

TYPE I-A TRUSS
8" ϕ PIPE SUPPORT FRAME DETAILS

OVERHEAD SIGN STRUCTURES
SUPPORT FRAME DETAILS ALUMINUM TRUSS

District 2
Overhead Sign
Structure Replacement

NUMBER	REVISION	DATE

DESIGNED -	20
CHECKED -	EXAMINED
DRAWN -	PASSED
CHECKED -	ENGINEER OF BRIDGES AND STRUCTURES

OS-A-4A

1-7-05

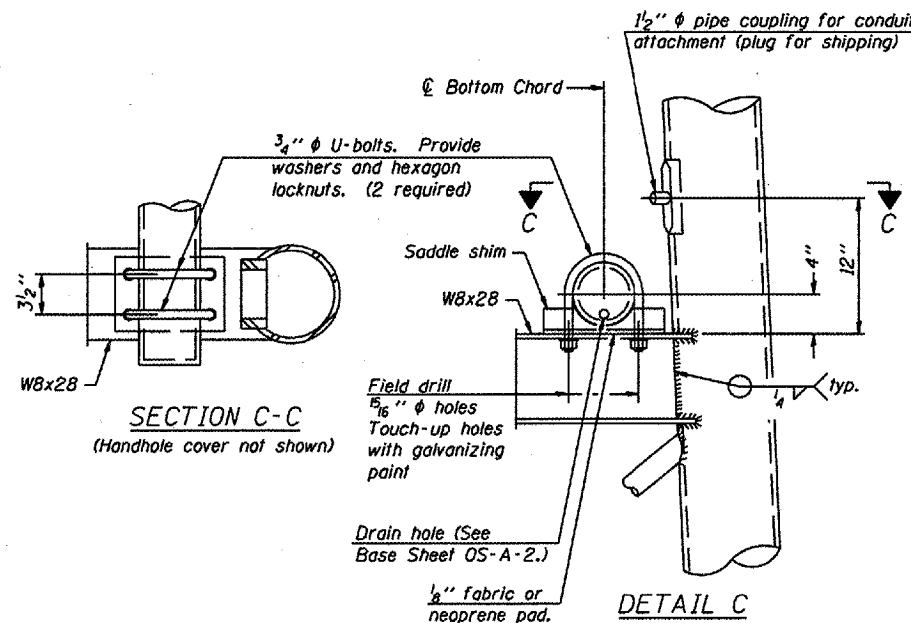

DETAIL C