

Center of horizontal to center of splice dimension may vary. Verify before drilling holes in mounting tube.

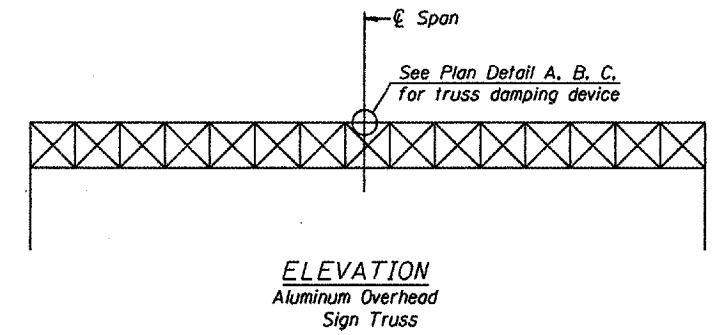

NOTES
Damper: One damper per truss.
(31 lbs. Stockbridge-Type Aluminum)
Cost included in Overhead Sign Structure...
Materials: Aluminum tubes shall be ASTM B221 alloy 6061 temper T6. Cost included in Overhead Sign Structure...

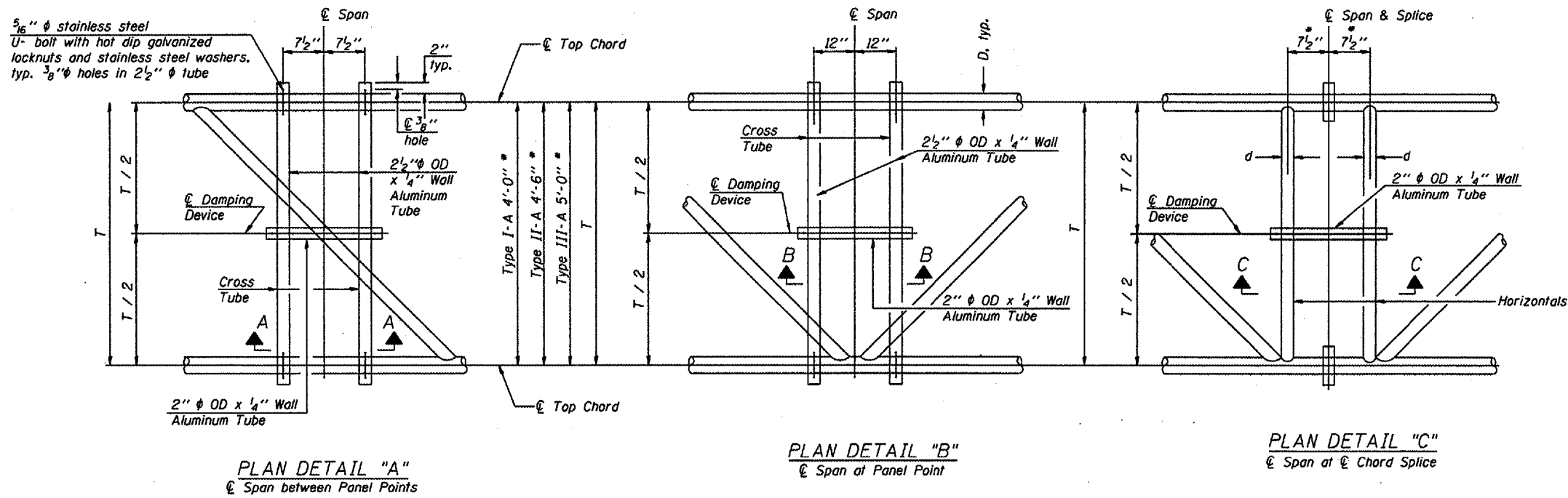
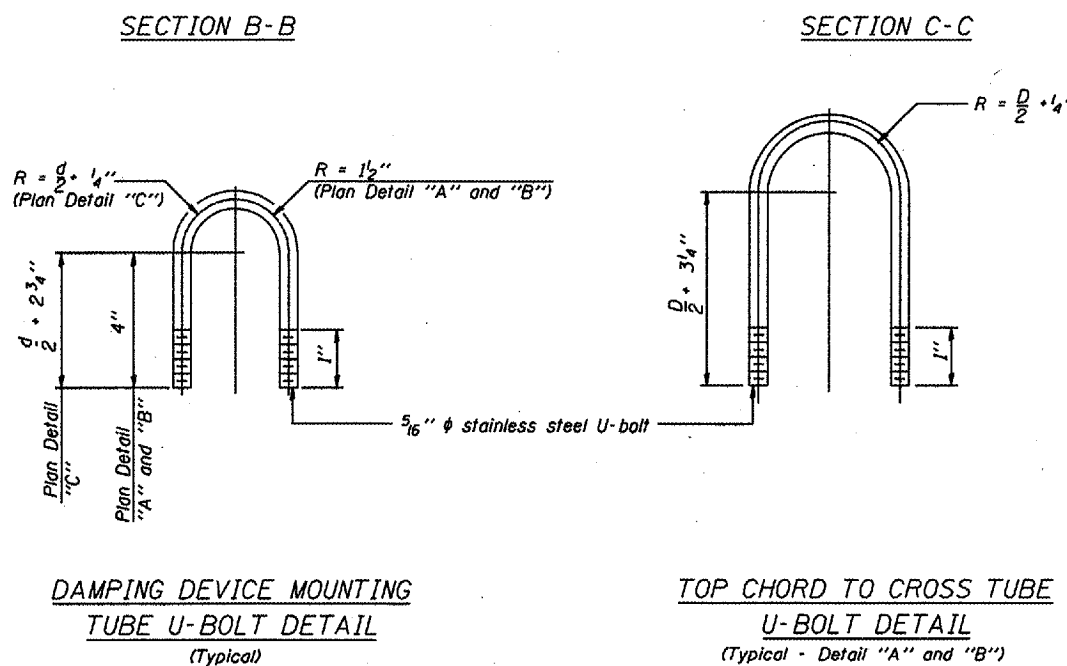
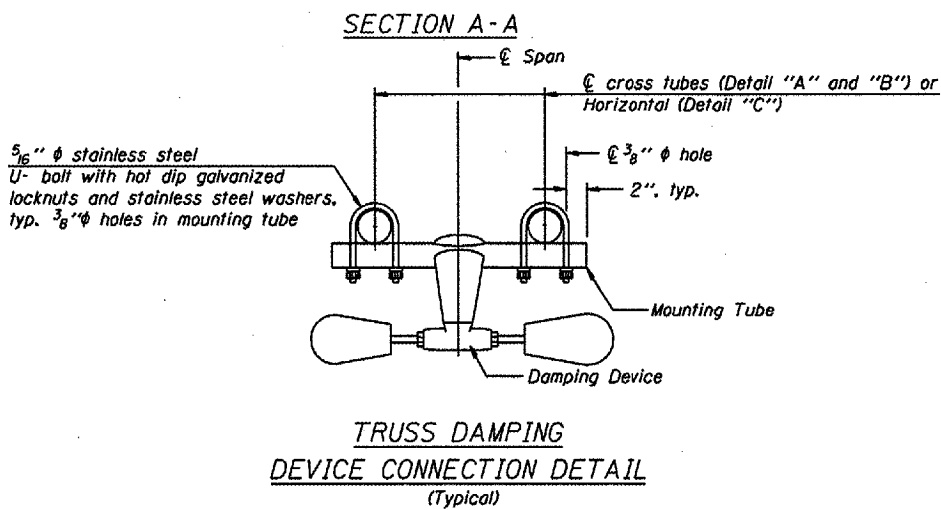
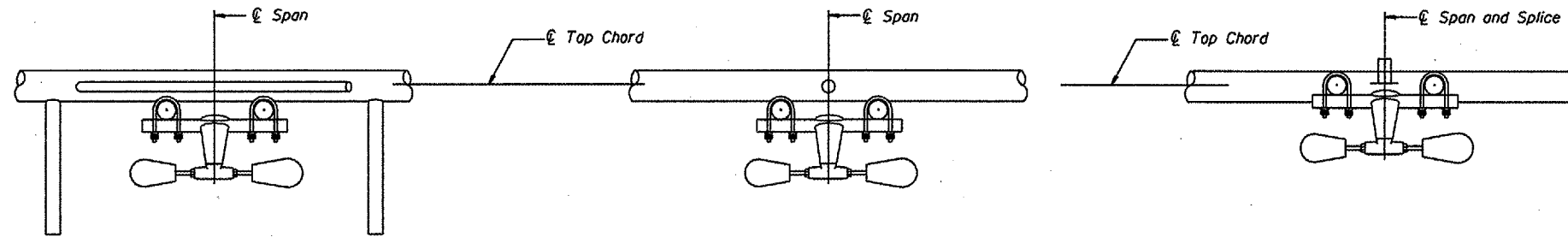

OVERHEAD SIGN STRUCTURE
DAMPING DEVICE

District 5
Overhead Sign Structure
Repair and Replacement

DESIGNED -	20
CHECKED -	EXAMINED
DRAWN -	PASSED
CHECKED -	ENGINEER OF BRIDGE DESIGN
	ENGINEER OF BRIDGES AND STRUCTURES