

PLAN DETAIL

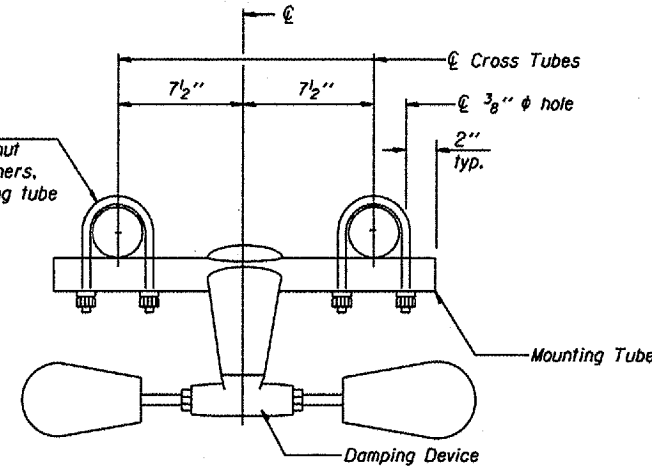

TRUSS DAMPING  
DEVICE CONNECTION DETAIL

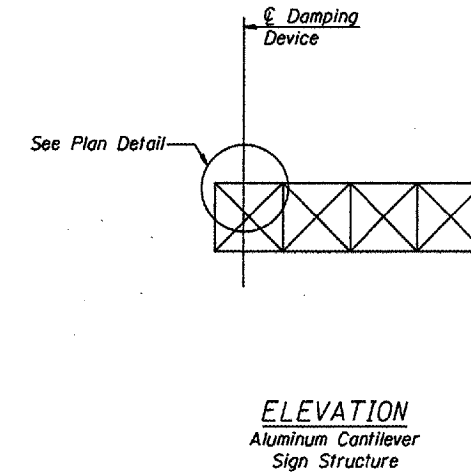

ELEVATION  
Aluminum Cantilever  
Sign Structure

GENERAL NOTES

- Damper: One damper per truss. (31 lbs. Stockbridge-Type Aluminum)
- Materials: Aluminum tubes shall be ASTM B221 alloy 6061 temper T6

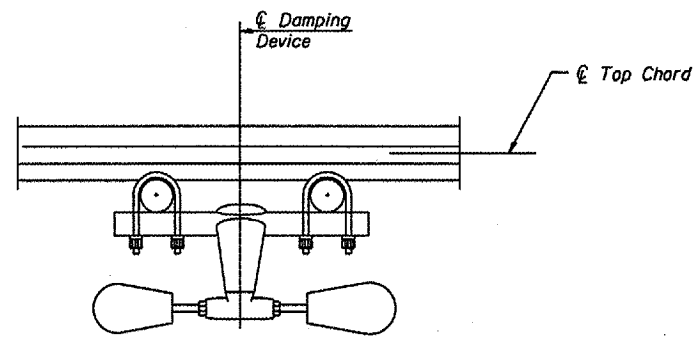

SECTION A-A

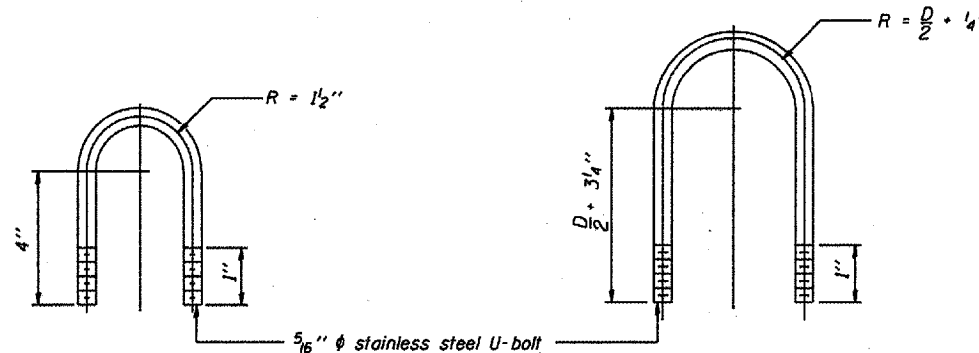

DAMPING DEVICE MOUNTING  
TUBE U-BOLT DETAIL  
(Typical)

TOP CHORD TO CROSS TUBE  
U-BOLT DETAIL  
(Typical)

DESIGNED -	20
CHECKED -	EXAMINED
DRAWN -	PASSED
CHECKED -	ENGINEER OF BRIDGES AND STRUCTURES

OSC-A-D

1-7-05

CANTILEVER SIGN STRUCTURE  
DAMPING DEVICE

District 7  
Overhead Sign Structure  
Repair and Replacement