

# STATE OF ILLINOIS DEPARTMENT OF TRANSPORTATION

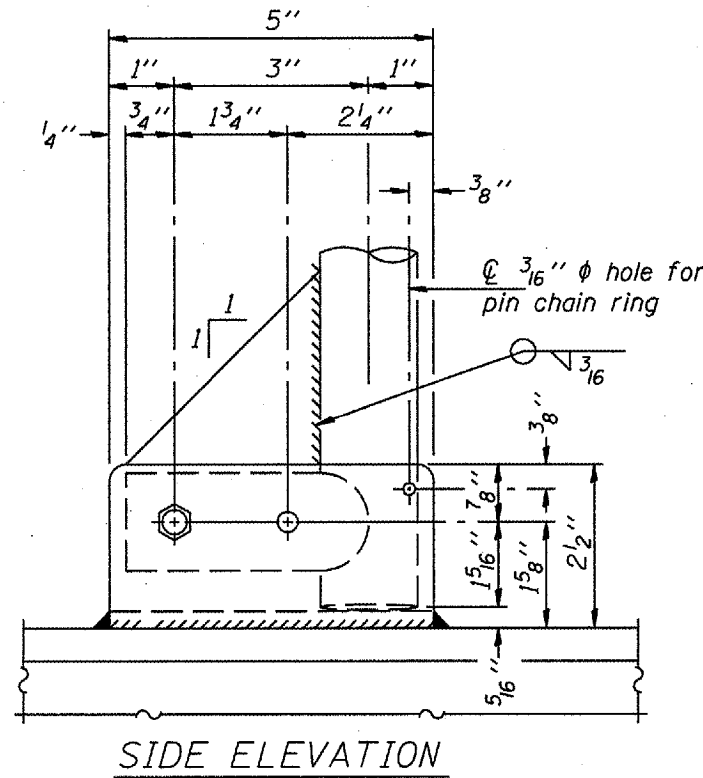

SIDE ELEVATION

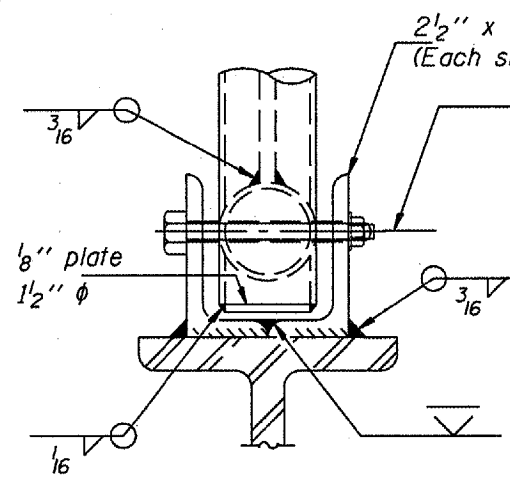

FRONT ELEVATION

**The existing locking pin hole to be reamed for proper alignment and a new oversized stainless steel pin to be installed.**

Details not shown same as "ELEVATION" at right.

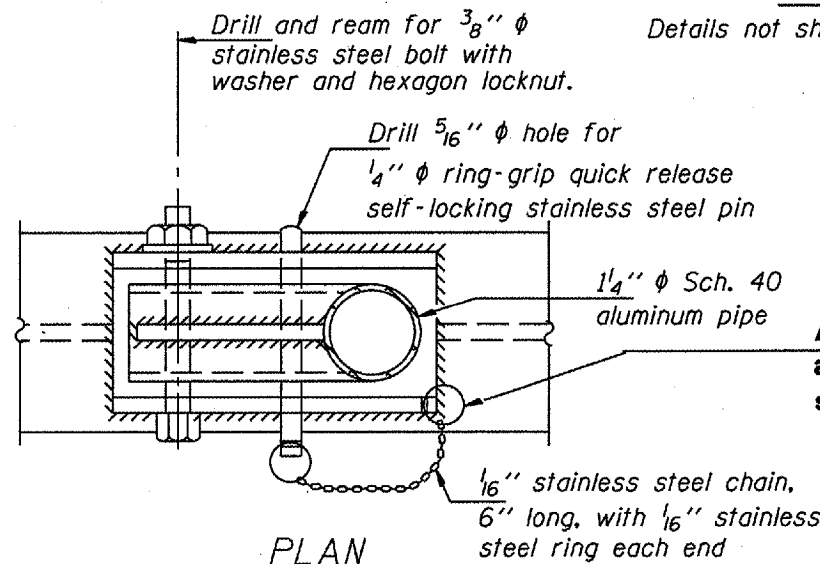

PLAN  
DETAIL E HANDRAIL HINGE

**A new stainless steel chain shall be attached to the angle with a 1/16" stainless steel ring.**

OVERHEAD SIGN STRUCTURES  
 HANDRAIL HINGE REPAIR DETAIL