

PIPE UNDERDRAIN 6", AT ROADWAY SAGS

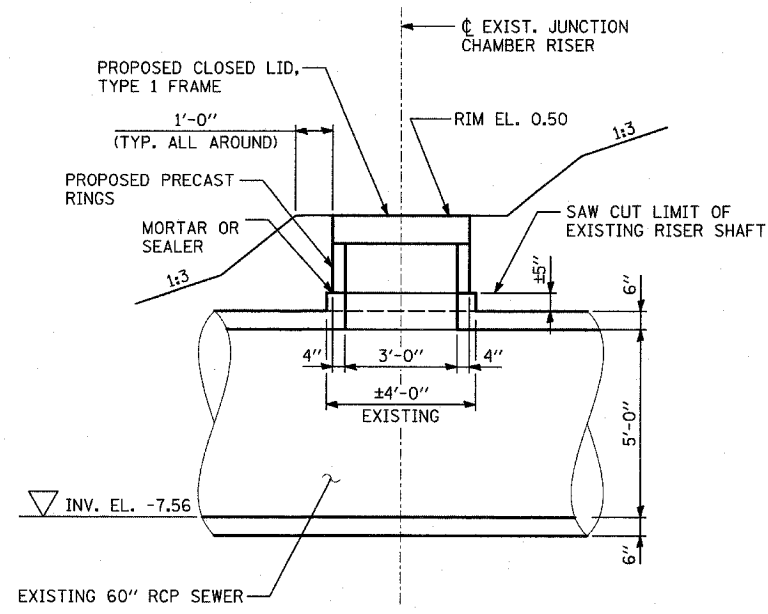

RISER SHAFT RECONSTRUCTION DETAIL

NOTE:
1. TO BE PAID FOR AS "MANHOLES TO BE RECONSTRUCTED"

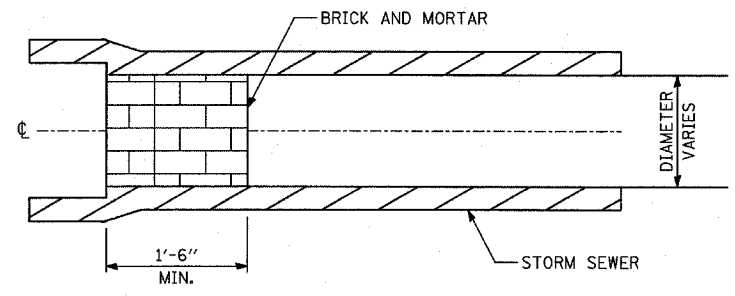

STORM SEWER PLUG

- NOTES:**
1. THIS WORK CONSISTS OF FURNISHING BRICKS AND MORTAR AS SHOWN AND AS DIRECTED BY THE ENGINEER AT LOCATIONS SHOWN IN THE PLANS TO PLUG THE EXISTING AND/OR PROPOSED STORM SEWER LATERAL STUBS. THIS PLUG WILL BE REMOVED BY OTHERS FOR FUTURE EXTENSION OF THE STORM SEWER.
 2. THIS WORK SHALL NOT BE PAID FOR SEPARATELY, PER ARTICLE 550.05.

REVISIONS	
NAME	DATE