

**DETAIL AT OVERHEAD SIGN FOUNDATIONS**  
NO SCALE

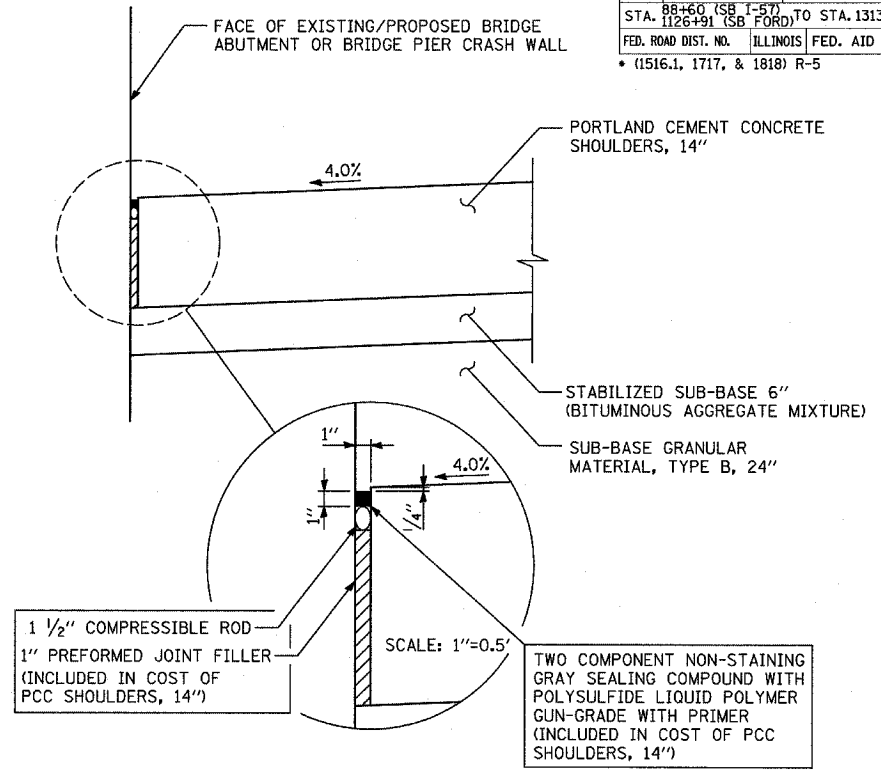

**PCC SHOULDERS ADJACENT TO BRIDGE ABUTMENT/CRASH WALL**  
SCALE: 1"=0.5"

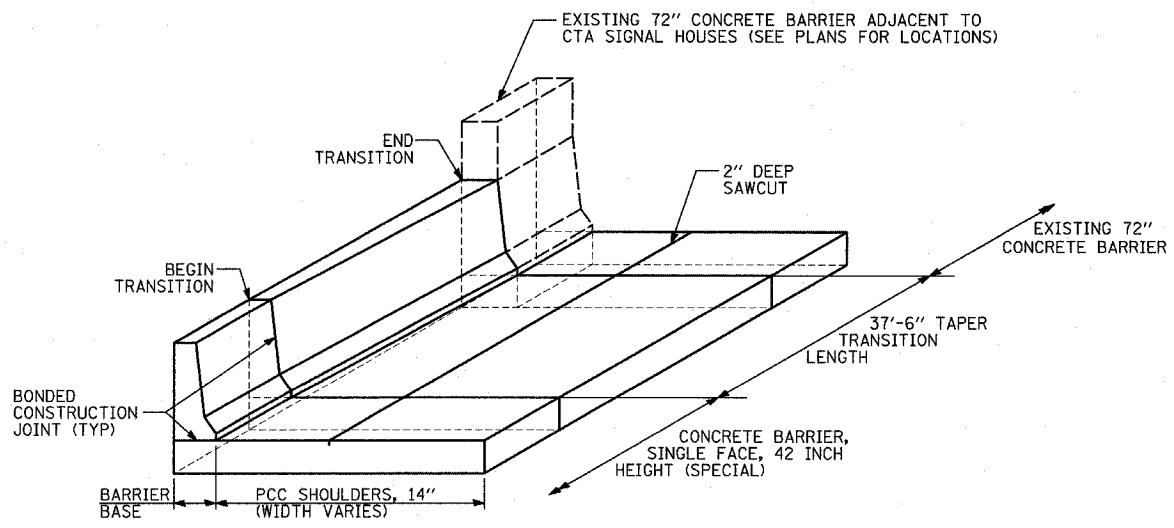

**72" CONCRETE BARRIER TRANSITION DETAIL**  
NO SCALE

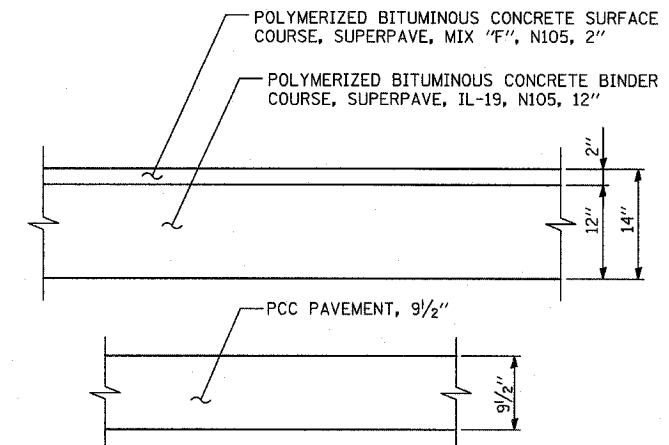

**TEMPORARY PAVEMENT DETAILS**  
(CONTRACTOR HAS THE OPTION OF USING BITUMINOUS OR PCC SECTION FOR TEMPORARY PAVEMENT)  
SCALE: 1"=1'-0"

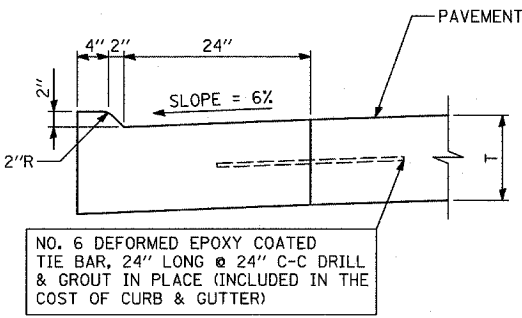

**COMBINATION CONCRETE CURB & GUTTER, TYPE M-2.24**  
SCALE: 1"=1'-0"

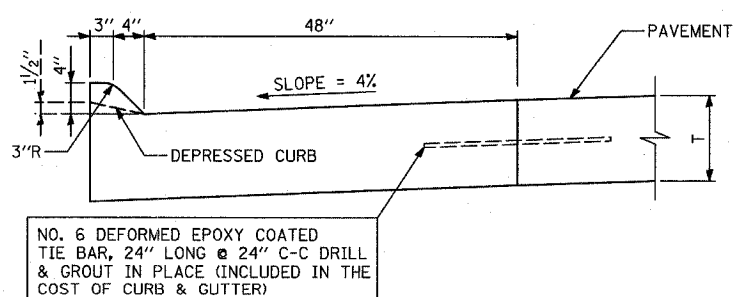

**COMBINATION CONCRETE CURB & GUTTER, TYPE M-4.48**  
SCALE: 1"=1'-0"

REVISIONS	
NAME	DATE