

ELEVATION
CTA FENCE (SPECIAL) ON CONCRETE BARRIER WALL

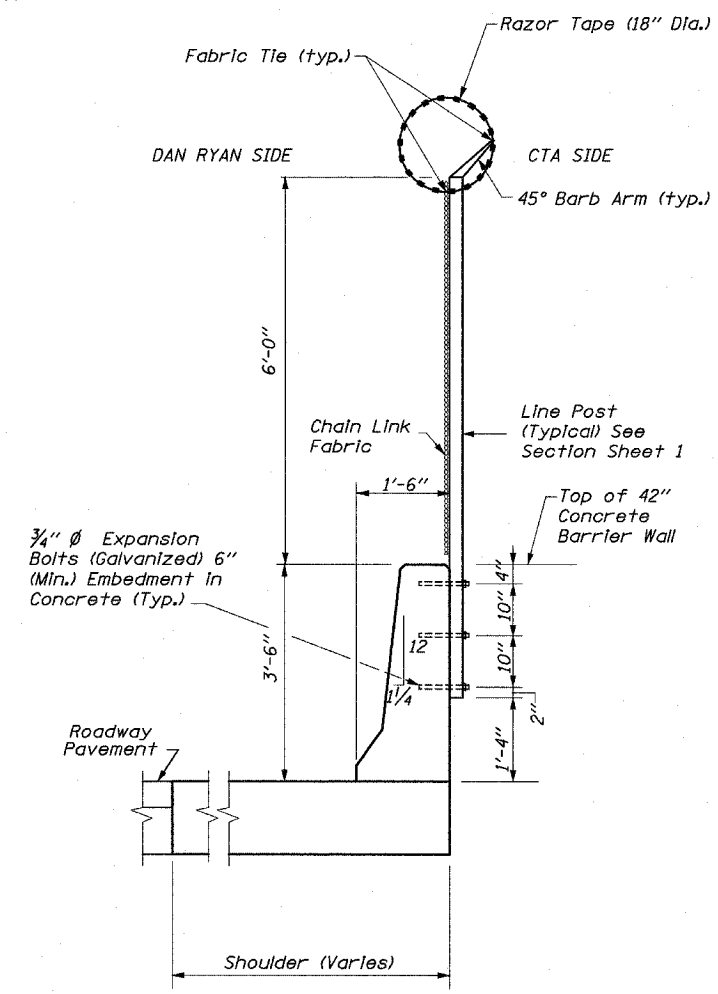

SECTION 3-3

NOTE:
Where the fence meets bridge piers and other vertical structures taller than the fence a maximum gap of 2" clear between the terminal post and the structure shall be provided.

TYLIN INTERNATIONAL

REVISIONS	
NAME	DATE

ILLINOIS DEPARTMENT OF TRANSPORTATION
F.A.I. 94 (DAN RYAN EXPRESSWAY)

CTA FENCE (SPECIAL)
ELEVATIONS AND DETAILS
SHEET 2 OF 4

SCALE: NONE
DATE: MARCH 1, 2006
DRAWN BY: MPG
CHECKED BY: TGB