

F.A.S. RTE.	SECTION	COUNTY	TOTAL SHEETS	SHEET NO.
567	04-00027-01-PV	MASON	79	72
STA.		TO STA.		
FED. ROAD DIST. NO.		ILLINOIS	FED. AID PROJECT	

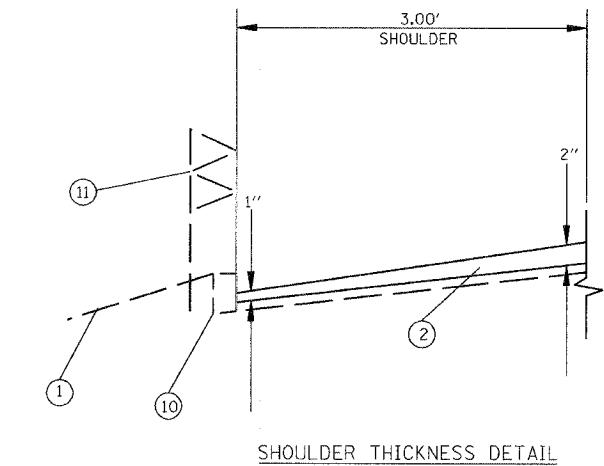
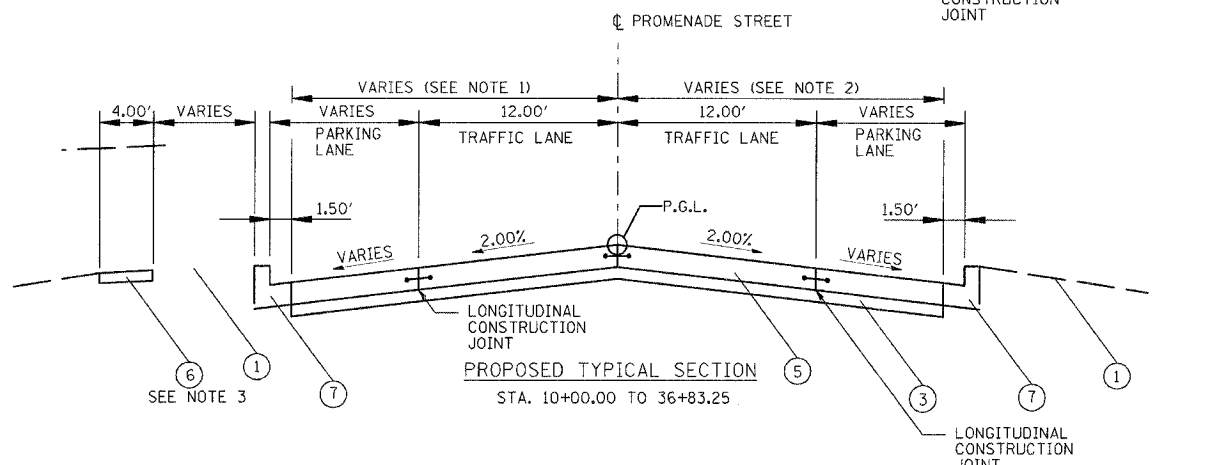
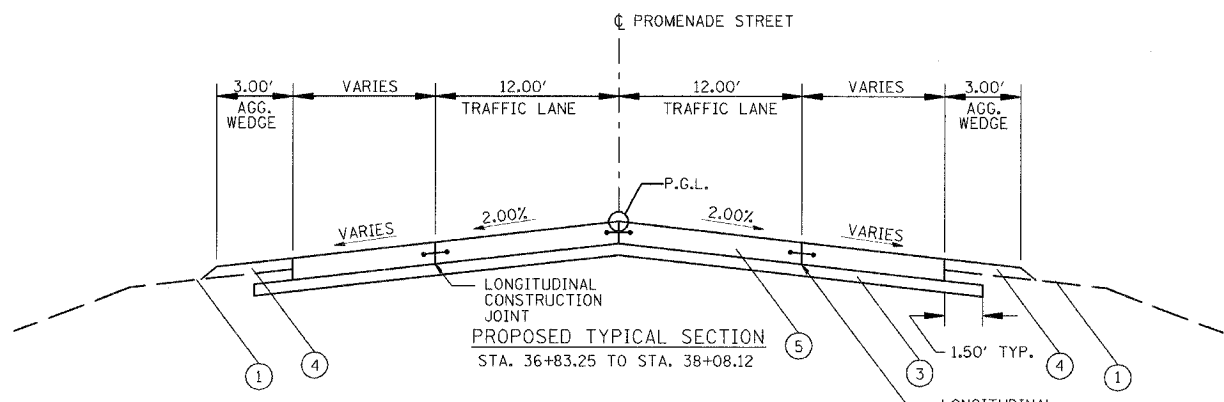
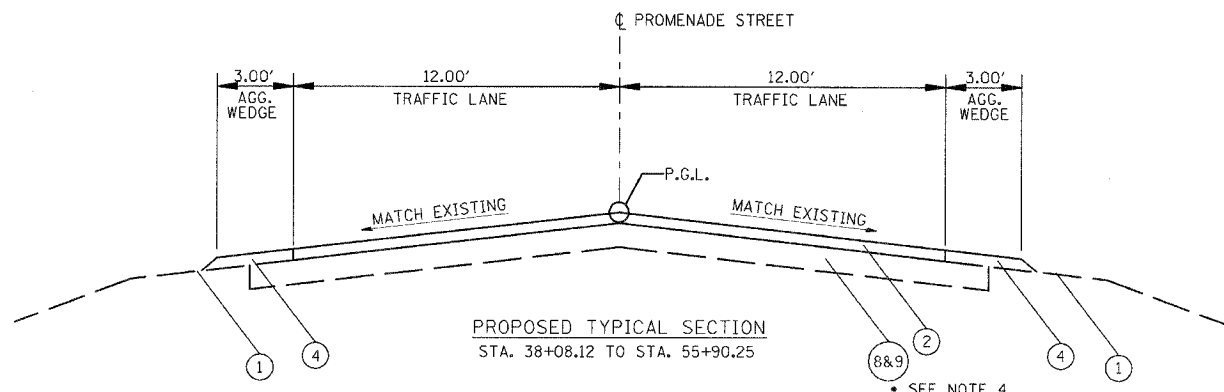
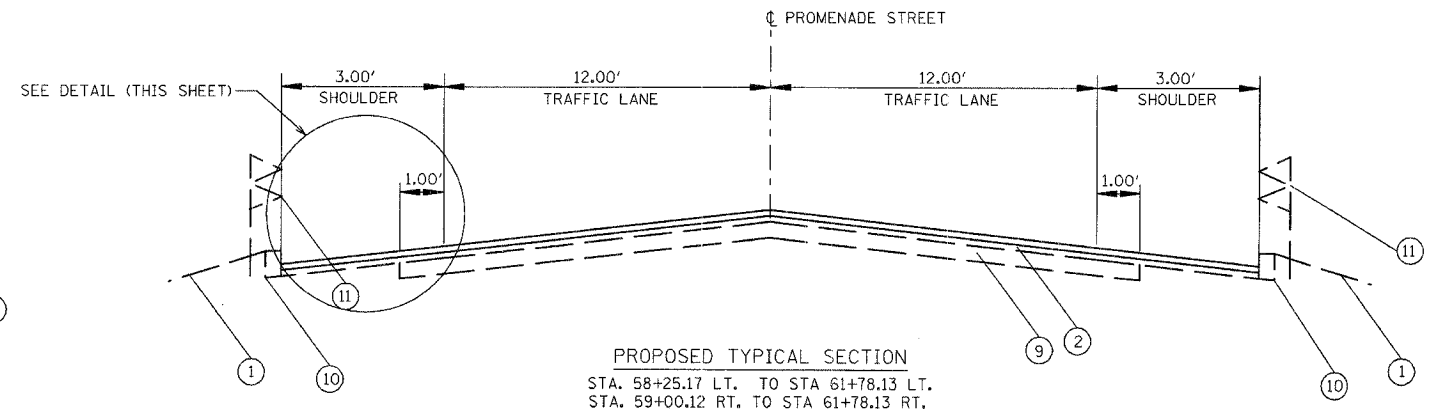
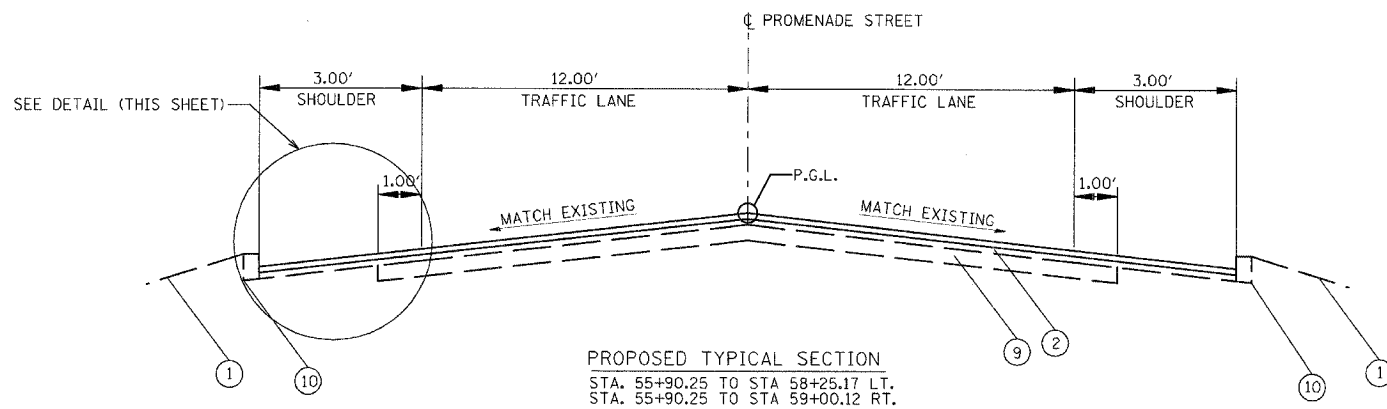

PROPOSED LEGEND

- ① EXISTING GROUND
- ② PROPOSED POLYMERIZED BITUMINOUS CONCRETE SURFACE COURSE, SUPERPAVE, MIX "D", N50 2"
- ③ PROPOSED SUBBASE GRANULAR MATERIAL, TYPE B 4"
- ④ PROPOSED AGGREGATE SHOULDER, TYPE B
- ⑤ PROPOSED PORTLAND CEMENT CONCRETE PAVEMENT
- ⑥ PROPOSED PORTLAND CEMENT CONCRETE SIDEWALK 4"
- ⑦ EXISTING CONCRETE CURB AND GUTTER, TYPE 5 (MODIFIED)
- ⑧ EXISTING 8" AGGREGATE SUBBASE W/ BITUMINOUS SURFACE (CLASS A/ CLASS I)
- ⑨ EXISTING SOIL CEMENT BASE COURSE - 6.50"
- ⑩ EXISTING BITUMINOUS CURB
- ⑪ EXISTING GUARDRAIL

STRUCTURAL DESIGN TRAFFIC:	YEAR	2015
PV =	88	SU = 4 MU = 8
ROAD / STREET CLASSIFICATION:	CLASS	II
PERCENT OF STRUCTURAL DESIGN TRAFFIC IN DESIGN LANE:	P =	50 S = 50 M = 50
TRAFFIC FACTOR:	ACTUAL TF =	4.04 AC TYPE =
	MINIMUM TF =	3.00
PG GRADE:	BINDER =	8 1/4" PCCP JOINTED W/ 1 1/2" DOWELS @ 15' MAX. JT. SPACING
SUBGRADE SUPPORT RATING:	SSR =	POOR (STA. 10+00.00 TO 38+08.12 )
	SSR =	(STA. TO )

- NOTES:
- 18.00' FROM STA 10+00 TO STA 12+69.10 INTERSECTION CONSTRUCTION FROM STA 12+69.10 TO STA 13+47.56  
 18.25' FROM STA 13+47.56 TO STA 16+65.27  
 INTERSECTION CONSTRUCTION FROM STA 16+65.27 TO STA 17+46.42  
 18.50' FROM STA 17+46.42 TO STA 20+65.09  
 INTERSECTION CONSTRUCTION FROM STA 20+65.09 TO STA 21+64.32  
 18.50' FROM STA 21+64.32 TO STA 24+92.32  
 INTERSECTION CONSTRUCTION FROM STA 24+92.32 TO STA 25+77.00  
 18.50' FROM STA 25+77.00 TO STA 28+88.31  
 INTERSECTION CONSTRUCTION FROM STA 28+88.31 TO STA 29+68.21  
 18.50' FROM STA 29+68.21 TO STA 36+83.25
  - 19.00' FROM STA 10+00 TO STA 12+92.03 INTERSECTION CONSTRUCTION FROM STA 12+92.03 TO STA 13+51.71  
 18.25' FROM STA 13+51.71 TO STA 16+65.28  
 INTERSECTION CONSTRUCTION FROM STA 16+65.28 TO STA 17+45.72  
 18.25' FROM STA 17+45.72 TO STA 20+65.09  
 INTERSECTION CONSTRUCTION FROM STA 20+65.09 TO STA 21+64.32  
 18.50' FROM STA 21+64.32 TO STA 24+92.12  
 INTERSECTION CONSTRUCTION FROM STA 24+92.12 TO STA 25+71.31  
 18.50' FROM STA 25+71.31 TO STA 28+87.83  
 INTERSECTION CONSTRUCTION FROM STA 28+87.83 TO STA 29+97.47  
 18.50' FROM STA 29+97.47 TO STA 36+83.25
  - SEE PCC SIDEWALK 4" SCHEDULE FOR NEW PCC SIDEWALK 4" LOCATIONS
  - ⑧ ENDS AT STATION 49+48.66 AND ⑨ BEGINS

REVISIONS	
NAME	DATE

ILLINOIS DEPARTMENT OF TRANSPORTATION  
 PROMENADE STREET (C.H. 20)  
 PROPOSED TYPICAL SECTIONS

SCALE: VERT. NTS  
 HORIZ.  
 DATE 8/04/05  
 DRAWN BY RDJ  
 CHECKED BY RXC

01:22:30 PM  
 02/14/2006 01:22 PM  
 FILES  
 LAYOUT KET B/04/05  
 DRAWN ICI 1/23/06  
 REVIEWED RXI 2/03/06