

F.A.S. RTE.	SECTION	COUNTY	TOTAL SHEETS	SHEET NO.
567	04-00027-01-PV	MASON	79	69
STA.	TO STA.			
FED. ROAD DIST. NO.	ILLINOIS	FED. AID PROJECT		

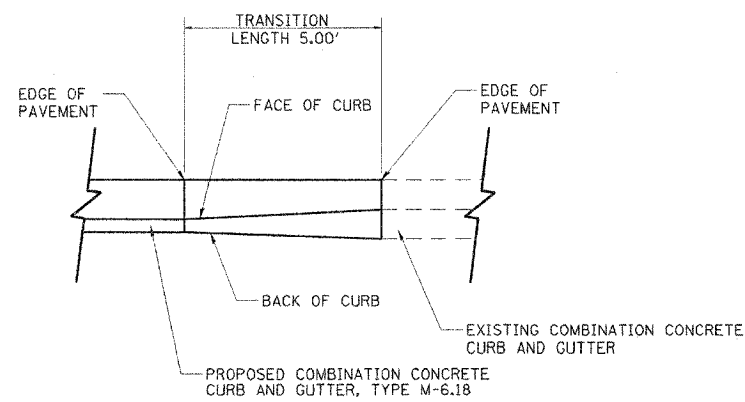

PLAN VIEW

TRANSITION FROM CONCRETE CURB & GUTTER M-6.18 TO EXISTING CURB AND GUTTER  
TO BE PAID FOR AS COMBINATION CONCRETE CURB AND GUTTER, TYPE M 6.18

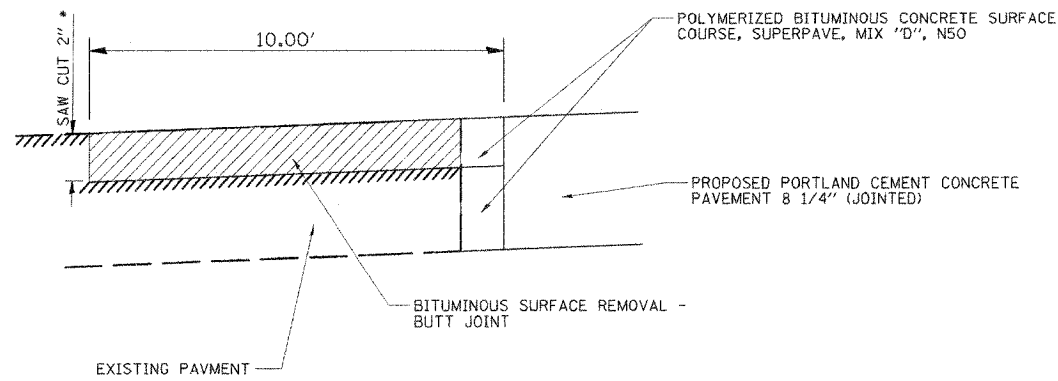

BUTT JOINT DETAIL  
STA 10+00.00

SAW CUT TO BE INCLUDED IN THE COST OF THE BITUMINOUS SURFACE REMOVAL - BUTT JOINT

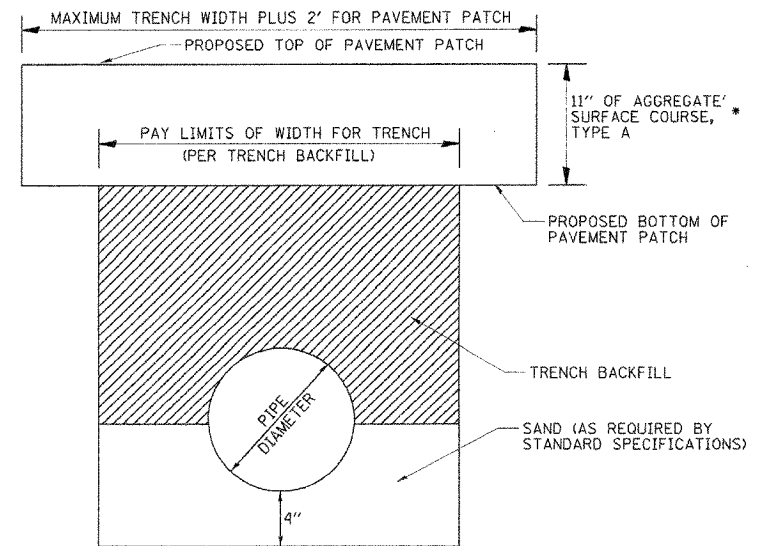

TEMPORARY PAVEMENT PATCH DETAIL  
LOCATIONS AS NOTED IN THE PLANS

TO BE PAID FOR AS TEMPORARY PAVEMENT PATCH

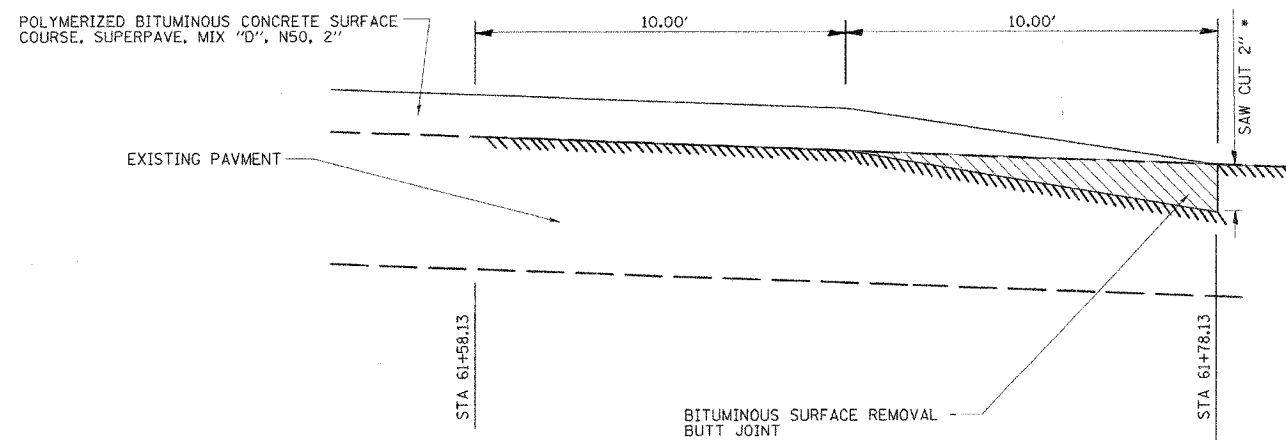

BUTT JOINT DETAIL  
STA 61+58.13

SAW CUT TO BE INCLUDED IN THE COST OF THE BITUMINOUS SURFACE REMOVAL - BUTT JOINT

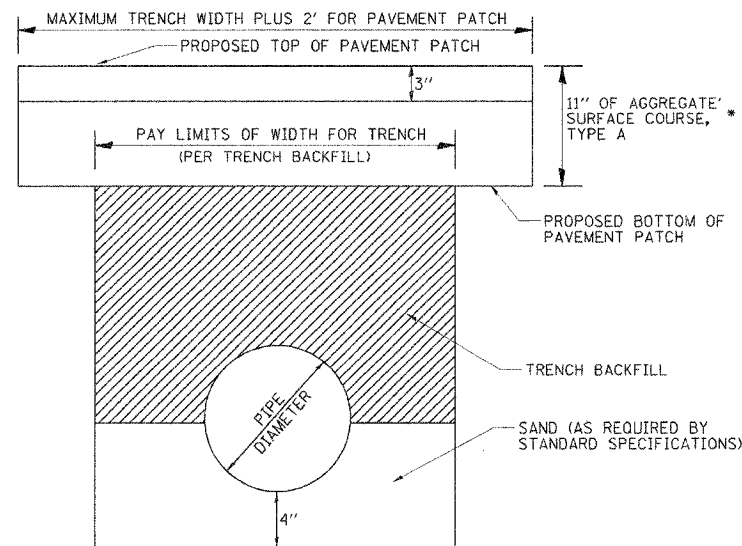

PAVEMENT PATCHING SPECIAL DETAIL  
LOCATIONS AS NOTED IN THE PLANS

TO BE PAID FOR AS PAVEMENT PATCHING SPECIAL

NOTE:

THIS CONDITION STATED WILL EXIST AS A TEMPORARY CONDITION UNTIL THE CONTRACTOR CAN RETURN TO REMOVE 3" OF AGGREGATE SURFACE COURSE, TYPE A AND REPLACE WITH THE 3" OF POLYMERIZED BITUMINOUS CONCRETE SURFACE COURSE, SUPERPAVE, MIX D, N50. THE INITIAL PLACEMENT OF THE 11" OF AGGREGATE SURFACE COURSE, TYPE A AND THE REMOVAL OF THE 3" OF AGGREGATE SURFACE COURSE, TYPE A AND SUBSEQUENT REPLACEMENT OF 3" OF POLYMERIZED BITUMINOUS CONCRETE SURFACE COURSE, SUPERPAVE, MIX D, N50 IS TO BE INCLUDED IN THE COST OF PAVEMENT PATCHING SPECIAL.

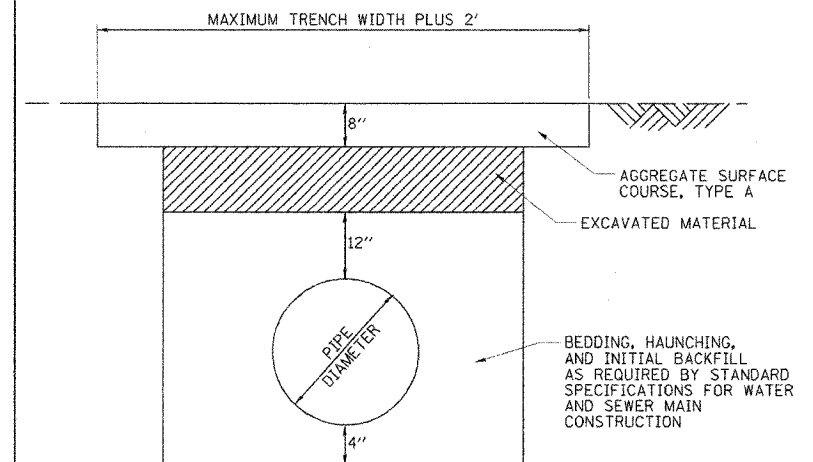

BACKFILL DETAIL  
WATERLINE LT STA 23+34

REVISIONS	
NAME	DATE

ILLINOIS DEPARTMENT OF TRANSPORTATION  
PROMENADE STREET (C.H. 20)  
MISCELLANEOUS ROADWAY DETAILS

SCALE: VERT. HORIZ. DATE 02/01/06

DRAWN BY JLW  
CHECKED BY RXC

03/25/06 PM 02:02:2806 03/25 PM #FILED

LAYOUT	KET	8/04/05
DRAWN	ELM	2/01/06
REVIEWED	JAD	2/02/06