

Holes in galvanized steel post and aluminum collar = bolt  $\phi + \frac{1}{16}$ ".  
Holes in stainless steel sleeve = bolt  $\phi + \frac{3}{16}$ ".

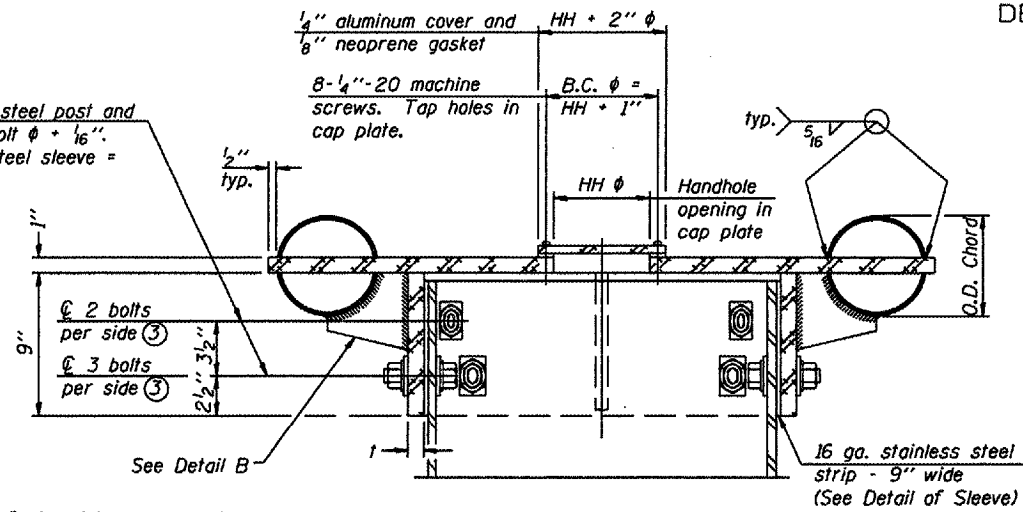

**SECTION B-B**  
Bolts, washers (including contoured washers), and locknuts shall be stainless steel.

④ Collar I.D. shall be manufactured to correspond to O.D. of actual galvanized post and stainless steel sleeve plus  $\frac{1}{8}$ " ( $\pm \frac{1}{16}$ "). Maximum gap between post and collar at any location equals  $\frac{1}{8}$ " before tightening bolts.

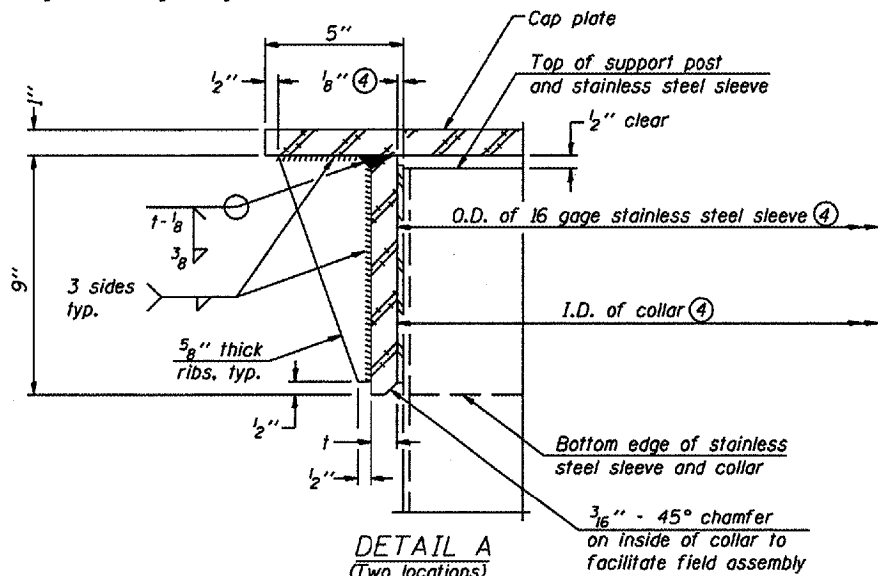

**DETAIL A**  
(Two locations)

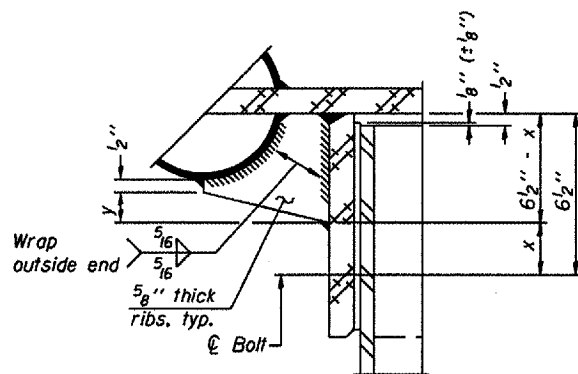

**DETAIL B**  
Two locations  
(For details not shown, see Detail C)

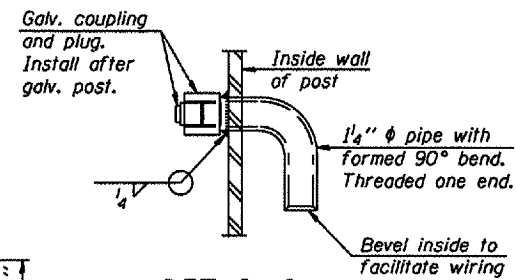

**DETAIL D**

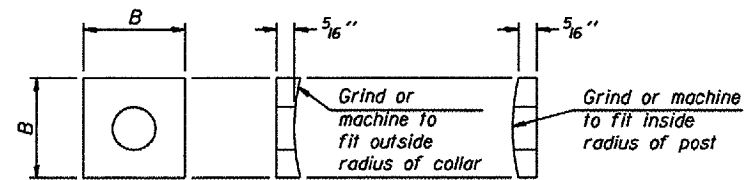

**CONTOURED WASHERS**

Bolt Size	Contoured Washers	
	Hole Dia.	B
7/8"	1"	2 1/2"
1"	1 1/8"	3"
1 1/4"	1 3/8"	3 1/4"

**DETAIL OF STAINLESS STEEL SLEEVE**

Weld to post after galvanizing.  
(Prepare post surface to insure tight, uniform fit and allow welding.)  
Welds to be 1/2" long at 6" cts. along top edge and at 1/4" opening.

NUMBER	REVISION	DATE

DESIGNED -	20
CHECKED -	EXAMINED
DRAWN -	PASSED
CHECKED -	ENGINEER OF BRIDGE DESIGN
	ENGINEER OF BRIDGES AND STRUCTURES

OSC-A-3 1-7-05

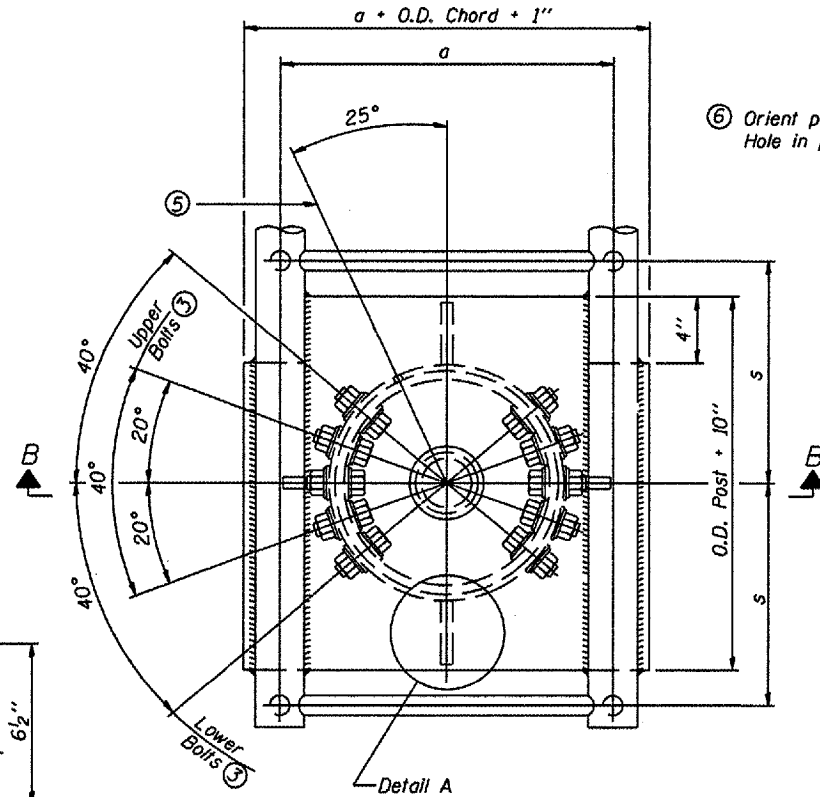

**PLAN VIEW - TOP OF COLUMN**

⑤ Optional full penetration weld in collar.  
(Two locations maximum....(180° apart)....X-ray or UT 100%)

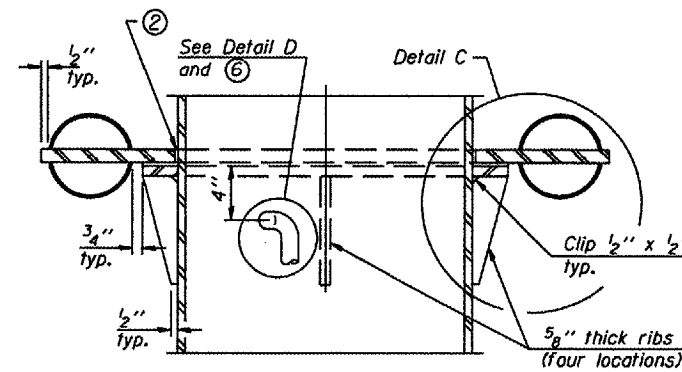

**SECTION C-C**

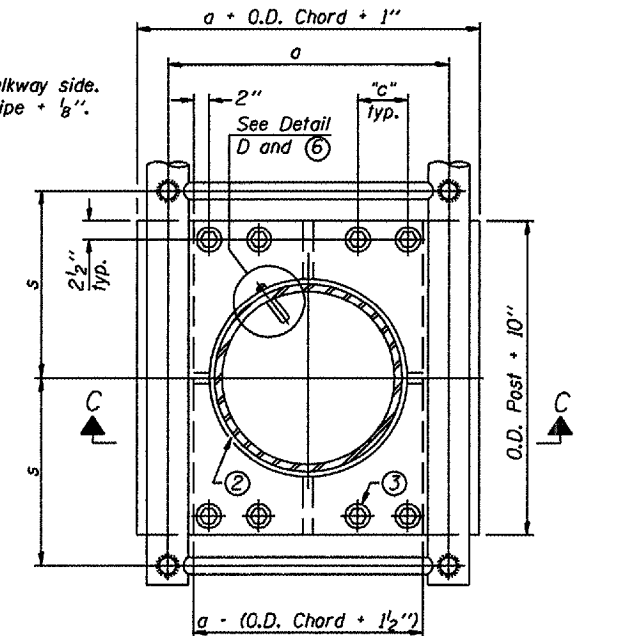

**SECTION THRU POST ABOVE LOWER CHORDS**

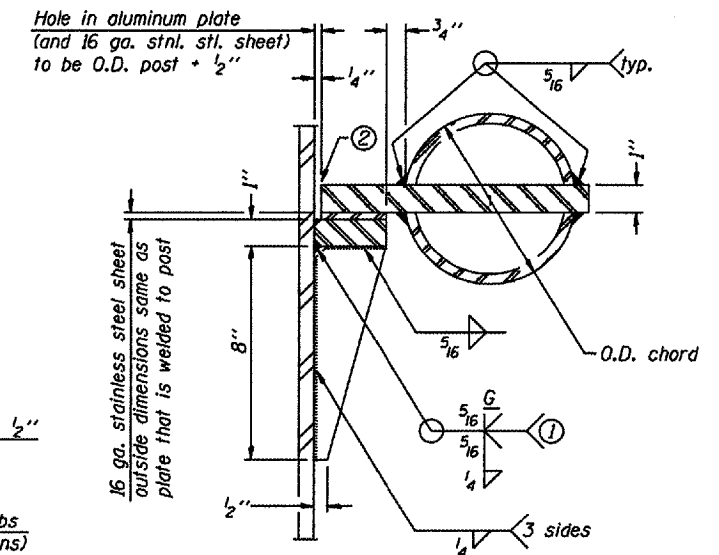

**DETAIL C**

① Grind top if required to fully seat aluminum plate and stainless steel sheet.

② After tightening lower connection bolts, fill gap with non-hardening, silicone caulk suitable for exterior exposure and acceptable to the Engineer. Cost is included in Overhead Sign Structure Cantilever.

Truss Type	Post Size	Upper & Lower Connection Bolt Diameter ③	Lower Juncture Bolt Spacing Dimension "c" ③	Opening in Cap Plate "HH"	Collar Thickness (t)	Side Ribs	
						x	y
I-C-A	16" $\phi$ (83#/' )	7/8"	3 1/4"	8"	5/8"	1 3/4"	2 1/4"
II-C-A	24" $\phi$ (125#/' )	1"	3 1/2"	12"	7/8"	2"	1 1/4"
III-C-A (35' max.)	24" $\phi$ (125#/' )	1 1/4"	3 1/2"	12"	7/8"	2"	1"
III-C-A (>35' to 40')	24" $\phi$ (171#/' )	1 1/4"	3 1/2"	12"	7/8"	2"	1"

③ Upper and lower connection bolts in collar and bolts at lower chord connection shall be high strength with matching locknuts. Connection bolts shall have 2 stainless steel flat washers each.

CANTILEVER SIGN STRUCTURES  
JUNCTURE DETAILS  
ALUMINUM TRUSS & STEEL POST

District 2  
Truss Repair & Replacement