

* Center of horizontal to center of splice dimension may vary. Verify before drilling holes in mounting tube.

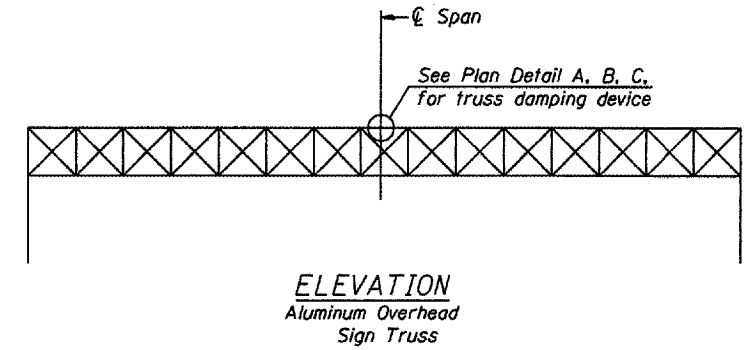
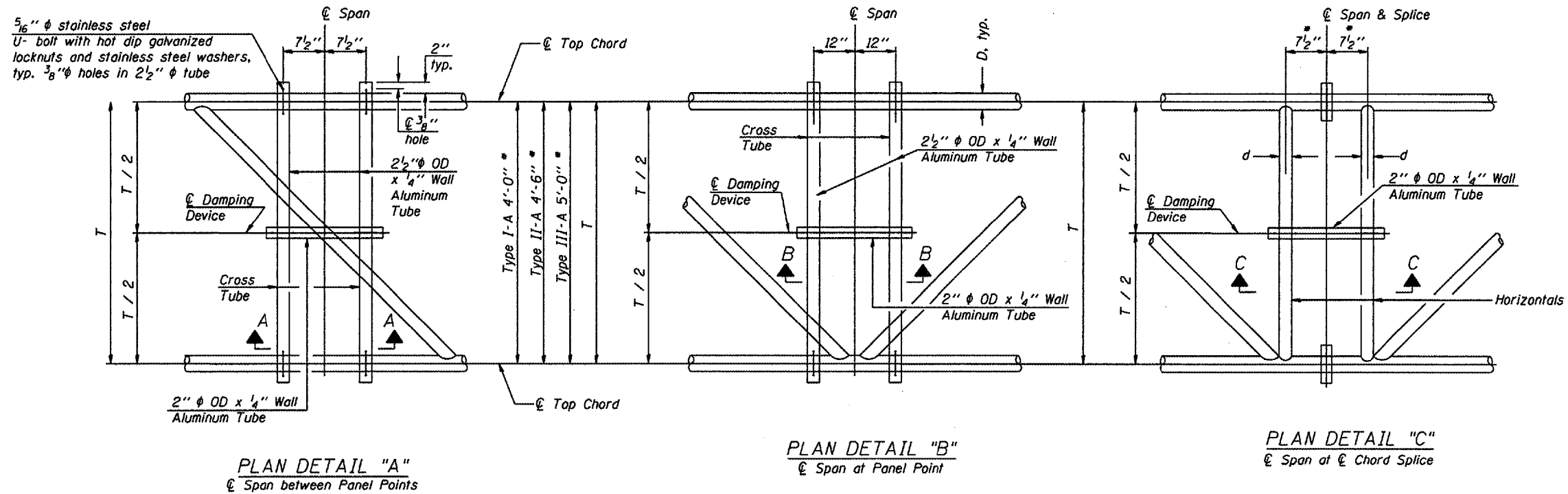

NOTES

Damper: One damper per truss.
(31 lbs. Stockbridge-Type Aluminum)
Cost included in Overhead Sign Structure...

Materials: Aluminum tubes shall be ASTM B221 alloy 6061 temper T6. Cost included in Overhead Sign Structure...

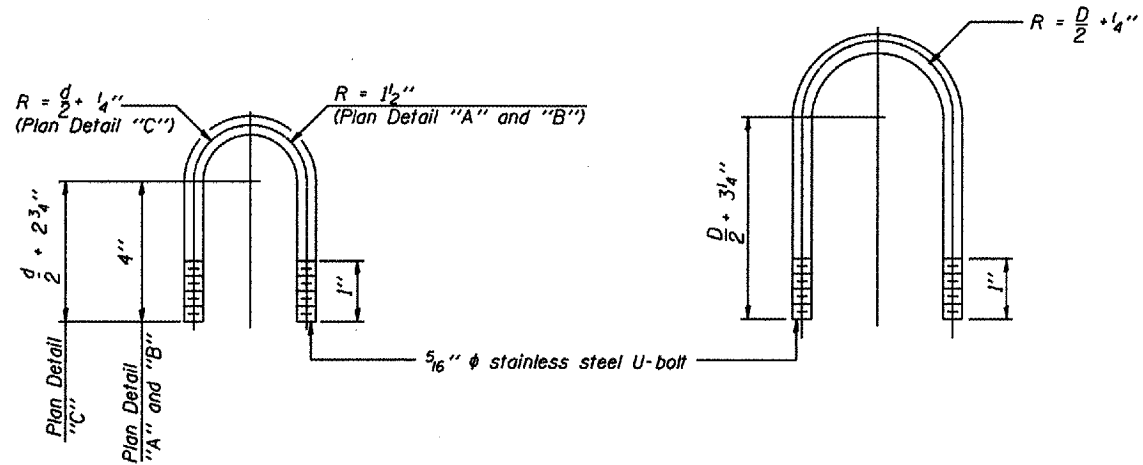
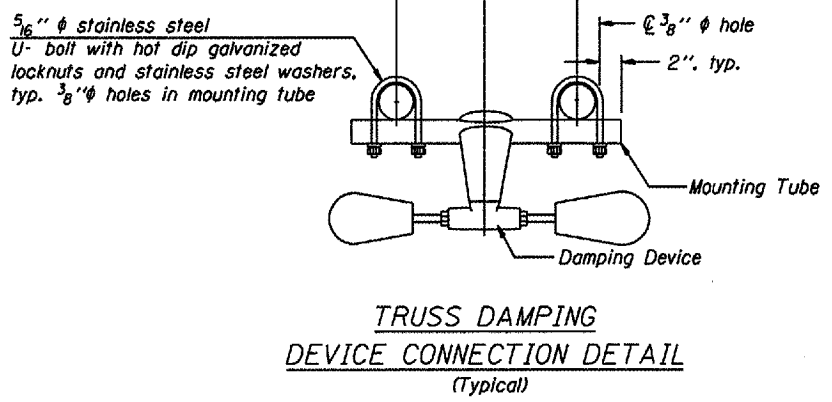
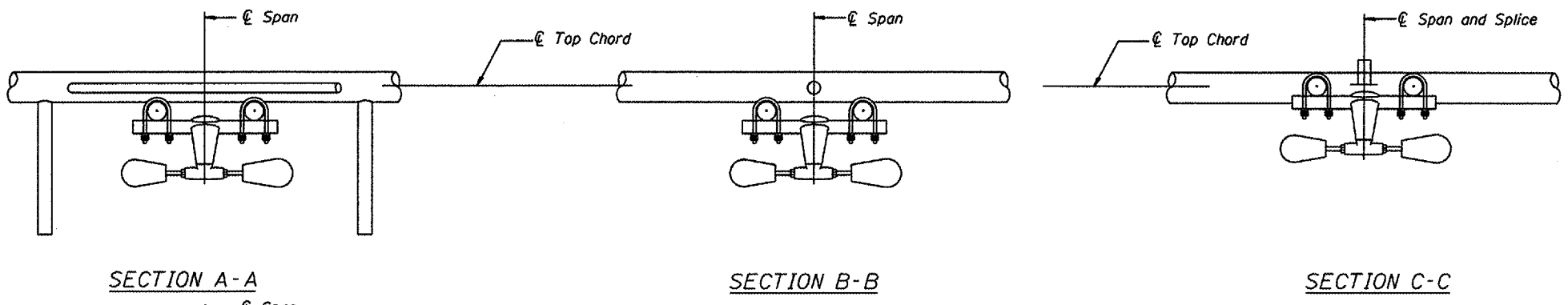

DESIGNED -	20
CHECKED -	EXAMINED
DRAWN -	ENGINEER OF BRIDGE DESIGN
CHECKED -	PASSED
	ENGINEER OF BRIDGES AND STRUCTURES

OVERHEAD SIGN STRUCTURE
DAMPING DEVICE

District 5
Truss Repair & Replacement