

F.A.I. RTE.	SECTION	COUNTY	TOTAL SHEETS	SHEET NO.
74	*	TAZEWELL	1366	61
STA.		TO STA.		
FED. ROAD DIST. NO.		ILLINOIS FED. AID PROJECT		
* (90-IDR-2; 9003,14,14-IDR-1				

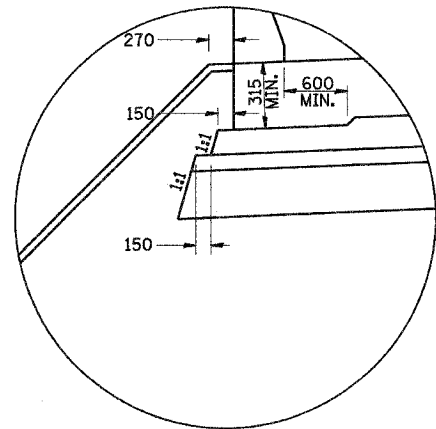

TYPICAL SUB-BASE DETAIL
(TO SHOW DIMENSIONS ONLY)

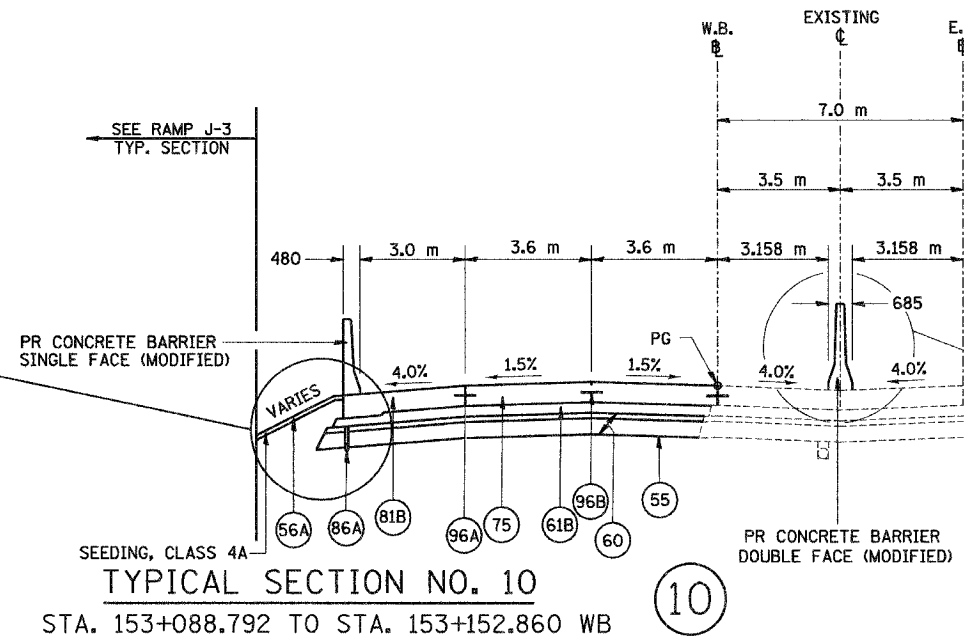

TYPICAL SECTION NO. 10
STA. 153+088.792 TO STA. 153+152.860 WB

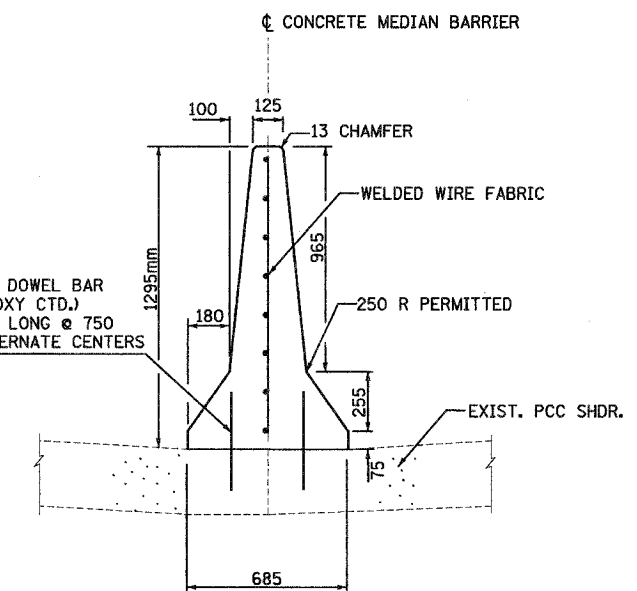

SECTION
TYPICAL CONCRETE BARRIER, DOUBLE FACE (MODIFIED). SEE I-74 STD. 637001-174.

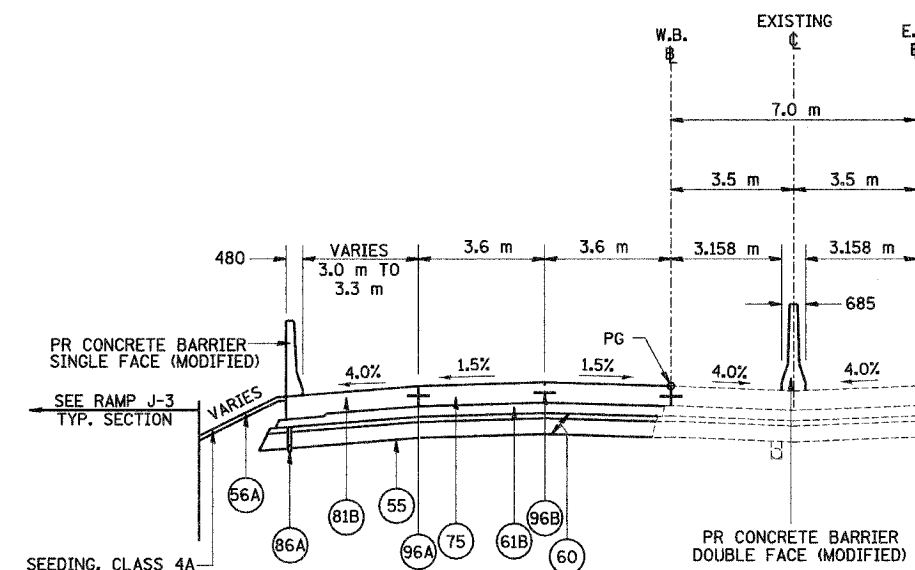

TYPICAL SECTION NO. 11
STA. 153+152.860 TO STA. 153+167.850 WB

NOTES:
SHOULDERS ADJACENT TO THE HIGH SIDE OF SUPERELEVATED PAVEMENT SHALL BE 4% OR 8% MINUS THE RATE OF SUPER, WHICHEVER IS LESS. ADJACENT TO THE LOW SIDE OF SUPERELEVATED PAVEMENT SHOULDERS SHALL HAVE A SLOPE OF 4% OR THE RATE OF SUPER, WHICHEVER IS GREATER.

ALL DIMENSIONS ARE IN MILLIMETERS (mm) UNLESS OTHERWISE STATED.

(60) IS SHOWN IN TWO LAYERS TO DENOTE THE TWO GRADATIONS THAT MAKE UP THIS PAY ITEM.

LEGEND		
(55) PR GEOTECHNICAL FABRIC FOR GROUND STABILIZATION	(81A) PR PORTLAND CEMENT CONCRETE SHOULDERS 250 MM	(89K) PR COMB. CONCRETE C&G, TYPE B-15.45
(56A) PR FURNISH AND PLACE TOPSOIL, 100 MM	(81B) PR PORTLAND CEMENT CONCRETE SHOULDERS, 290 MM	(96A) PR LONGITUDINAL CONSTRUCTION JOINT (TYPICAL)
(60) PR AGGREGATE SUB-BASE, 300 MM	(82) PR RETAINING WALL (SEE WALL PLANS)	(96B) PR SAWED LONGITUDINAL JOINT (TYPICAL)
(61A) PR BITUMINOUS CONCRETE BINDER COURSE, SUPERPAVE, IL-19.0L (LOW ESAL), 100MM	(86A) PR PIPE UNDERDRAINS, 100 MM	
(61B) PR BITUMINOUS CONCRETE BINDER COURSE, SUPERPAVE, IL-19.0L (LOW ESAL), 150MM	(86B) PR PIPE UNDERDRAINS, 150 MM	
(71D) PR PORTLAND CEMENT CONCRETE PAVEMENT 250MM (JOINTED)	(88) PR CONCRETE GUTTER, TYPE A (MODIFIED)	
(75) PR CONTINUOUSLY REINFORCED PORTLAND CEMENT CONCRETE PAVEMENT, 290 MM	(89B) PR COMB. CONCRETE C&G, TYPE B-15.60	
(79) PR AGGREGATE SHOULDERS, TYPE B		

REVISIONS	
NAME	DATE

ILLINOIS DEPARTMENT OF TRANSPORTATION
FAI ROUTE 74 (I-74)
PROPOSED TYPICAL SECTIONS
FAI ROUTE 74 (I-74) (WB)
NUMBERS 10 & 11
DRAWN BY DER
CHECKED BY MLB
DATE 12-20-04

