

ROUTE NO.	SECTION	COUNTY	TOTAL SHEETS	SHEET NO.
F.A.I. 74	90-13HVB	TAZEWELL	1366	506
FED. ROAD DIST. NO. 7	ILLINOIS	FED. AID PROJECT-		

SHEET NO. 58
68 SHEETS

STATE OF ILLINOIS
DEPARTMENT OF TRANSPORTATION

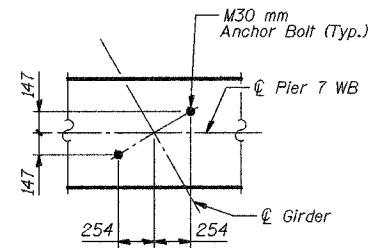

DETAIL 2

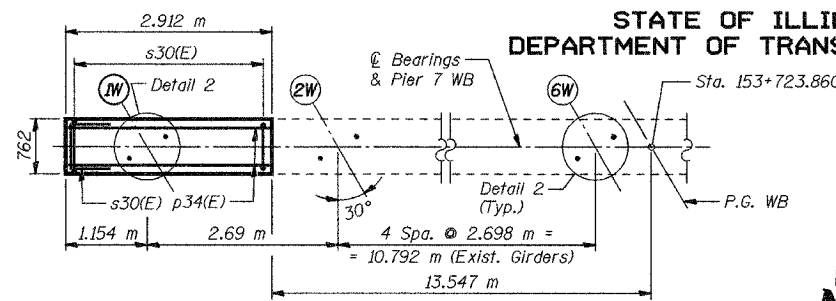

TOP PLAN

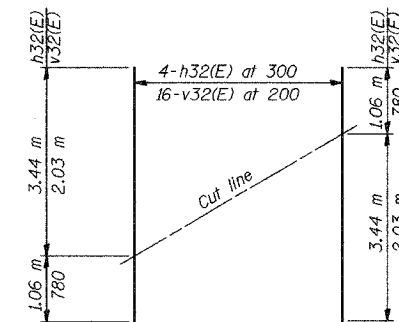

FIELD CUTTING DIAGRAM

* Order h32(E) and v32(E) bars full length. Cut to fit and use the remainder of bars in opposite face.

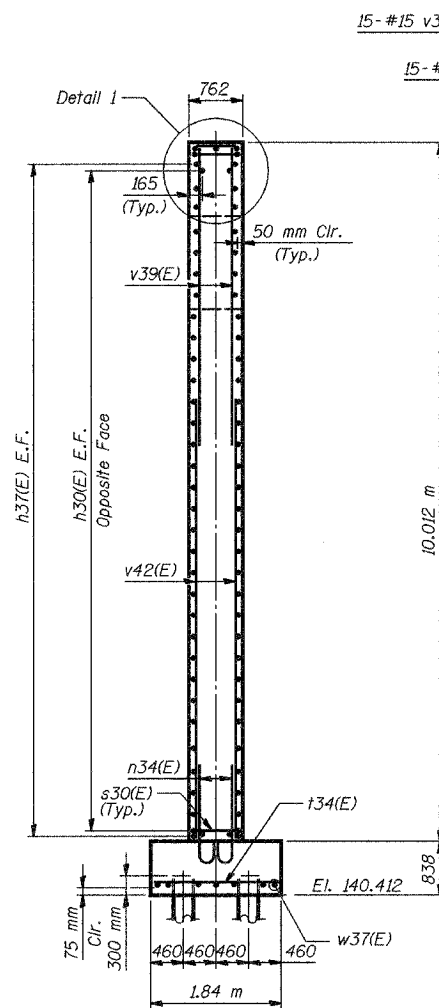

END VIEW

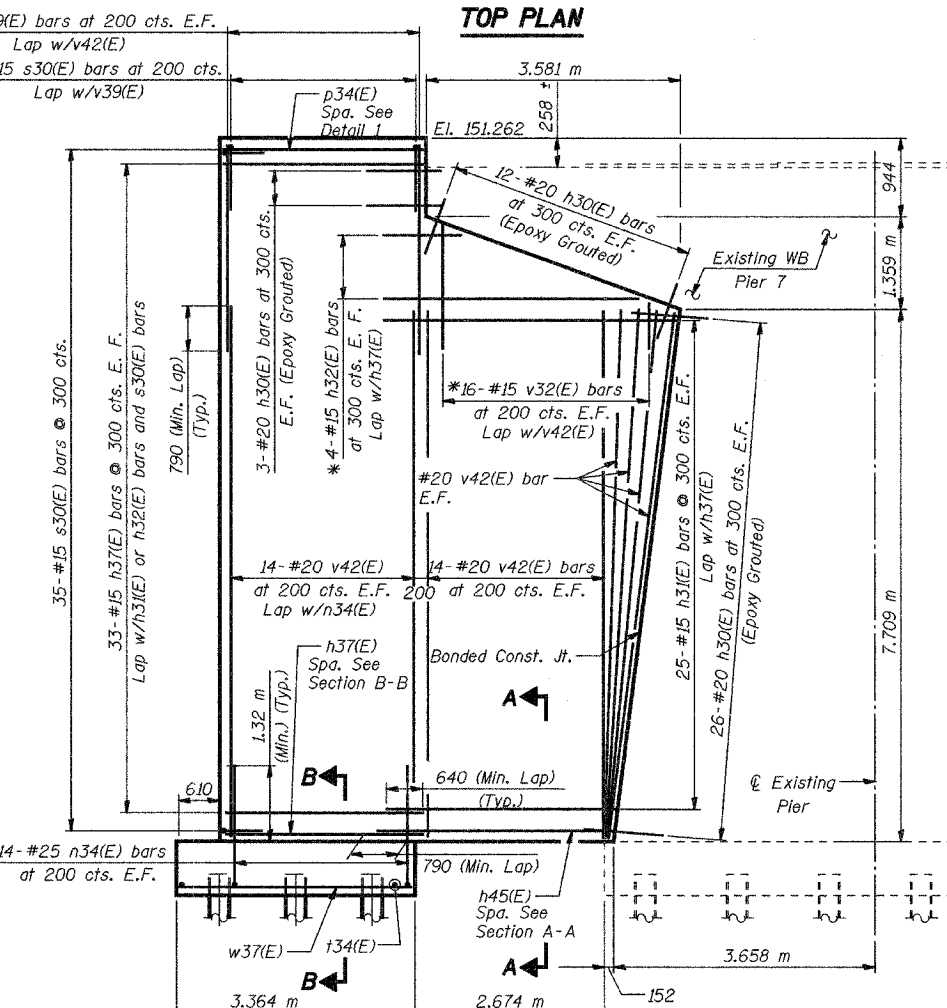

ELEVATION (LOOKING SOUTH)

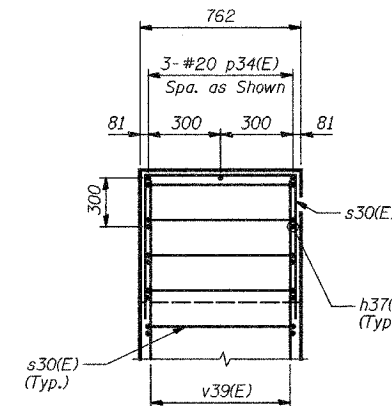

DETAIL 1

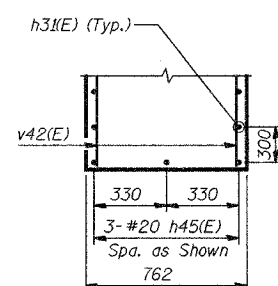

SECTION A-A

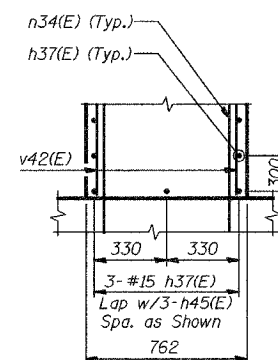

SECTION B-B

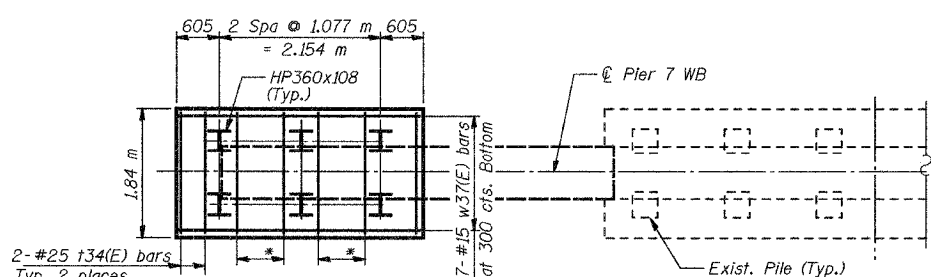

FOOTING PLAN

PILE DATA

Type Steel HP 360x108
Capacity Driven to refusal
Est. Length 11.5 m
No. Required 6

BILL OF MATERIAL

Bar	No.	Size	Length (m)	Shape
h30(E)	82	#20	1.00	—
h31(E)	50	#15	4.3	—
h32(E)	4	#15	4.5	—
h37(E)	69	#15	2.81	—
h45(E)	3	#20	4.1	—
n34(E)	28	#25	2.33	—
p34(E)	3	#20	2.81	—
s30(E)	50	#15	1.62	—
t34(E)	14	#25	1.74	—
v32(E)	16	#15	2.81	—
v39(E)	30	#15	3.2	—
v42(E)	64	#20	7.66	—
w37(E)	7	#15	3.26	—
Structure Excavation		m ³	72	
Concrete Structures		m ³	40	
Reinforcement Bars, Epoxy Coated		kg	2,810	
Furnishing Steel Piles HP360x108		m	69	
Driving Steel Piles		m	69	
Bridge Seat Sealer		m ²	11.9	

NOTES:

1. Reinforcement bars designated (E) shall be epoxy coated.
2. Concrete clear cover shall be 50 mm minimum unless noted otherwise.
3. Space Reinforcement in Cap to miss Anchor Bolts.
4. Epoxy Grout Bar h30(E) in minimum 230 mm deep drilled holes.
5. The material and installation shall be in accordance with IDOT Standard Specification Section 584.
6. Bonded Construction Joint at Interface between existing concrete and proposed concrete shall be in accordance with Standard Specifications Article 503.09(a)(2).
7. For Anchor Bolt Details, see Sheet 41.
8. All edges shall have standard 20 mm chamfers except as noted.
9. Min. Lap for Bar #15=640 mm, #20=790 mm, #25=1.32 m.
10. Space h30(E) bar to miss existing reinforcement in Pier.
11. All dimensions are in millimeters (mm) except as noted.
12. Clean exist. WB Pier beam seats and apply Bridge Seat Sealer to new and the exist. beam seats.

PIER 7 EXTENSION DETAILS

Date	Designed EV	WESTBOUND F.A.I. ROUTE 74 OVER CAMP STREET, FARM CREEK, AND TP&W RR F.A.I. RTE. 74 SECTION (90-13HVB)BY TAZEWELL COUNTY STATION 153+625.193 STRUCTURE NO. 090-0009	Sheet No.
Revisions	Drawn EV		58
	Checked NPP		of 68
	Approved NPP		
Prepared By: BRW, Inc. A Division of URS		1701 Golf Rd., Suite 1000 Rolling Meadows, IL.	BRW Job No. 17049-071