

ROUTE NO.	SECTION	COUNTY	TOTAL SHEETS	SHEET NO.
F.A.I. 74	(90-14HB)BR	TAZEWELL	1366	540
FED. ROAD DIST. NO. 7	ILLINOIS	FED. AID PROJECT		

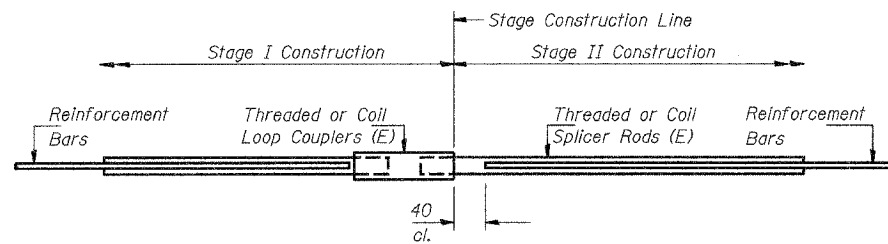

BAR SPLICER ASSEMBLY DETAIL

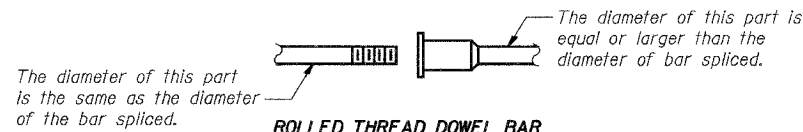

ROLLED THREAD DOWEL BAR



**** ONE PIECE**

Wire Connector



WELDED SECTIONS

BAR SPLICER ASSEMBLY ALTERNATIVES

** Heavy Hex Nuts conforming to ASTM A 563M, Grade C, D or DH may be used.

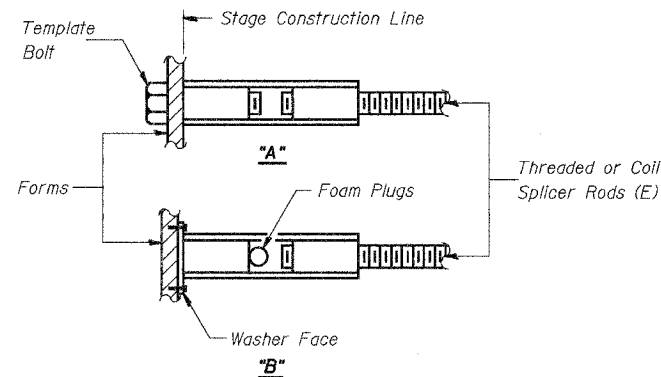

INSTALLATION AND SETTING METHODS

"A" : Set bar splicer assembly by means of a template bolt.
"B" : Set bar splicer assembly by nailing to wood forms or cementing to steel forms.
(E) : Indicates epoxy coating.

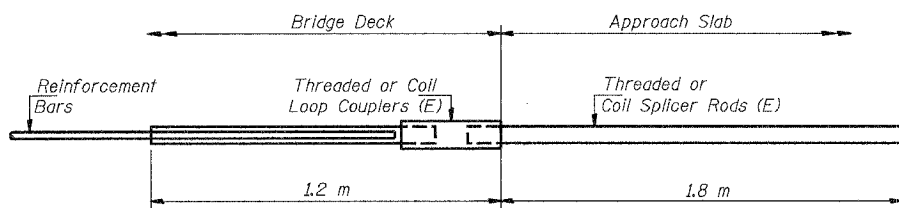

**INTEGRAL ABUTMENT
BAR SPLICER ASSEMBLY DETAIL
FOR #15 BAR**

Min. Capacity = 100 kN - tension
Min. Pull-out Strength = 40 kN - tension
No. Required = 103

NOTES

Bar splicer assemblies shall be of an approved type and shall develop in tension at least 125 percent of the yield strength of the lapped reinforcement bars.
Splicer rods shall be of minimum 400 MPa yield strength, threaded or called full length. All reinforcement bars shall be lapped and tied to the splicer rods or dowel bars. Bar splicer assemblies shall be epoxy coated according to the requirements for reinforcement bars.
Other systems of similar design may be submitted to the Engineer for approval. Approval shall be based on certified test results from an approved testing laboratory that the proposed bar splicer assembly satisfies the following requirements:

- ① Minimum Capacity = $1.25 \times 10^{-3} \times f_y \times A_t$
(Tension in kN)
- ② Minimum *Pull-out Strength = $1.25 \times 10^{-3} \times f_{s\ allow} \times A_t$
(Tension in kN)

Where f_y = Yield strength of lapped reinforcement bars in MPa.
 $f_{s\ allow}$ = Allowable tensile stress in lapped reinforcement bars in MPa (Service Load)
 A_t = Tensile stress area of lapped reinforcement bars (mm²).
* = 28 day concrete

BAR SPLICER ASSEMBLIES			
Bar Size to be Spliced	Splicer Rod or Dowel Bar Length	Strength Requirements	
		Min. Capacity kN - tension	Min. Pull-Out Strength kN - tension
#15	610 mm	100	40
#20	790 mm	150	60
#25	1.32 m	250	100
#30	1.85 m	350	140

Bar splicer (E) assemblies shall be according to Section 508 of the Standard Specifications, except as noted. The furnishing and installation of bar splicer assemblies will be measured and paid for at the contract unit price each for BAR SPLICERS.

The unused half of the bar splicers from the construction of SN 090-0162 were bundled together, clearly labeled with structure number, size, and location within the structure (for example: SN 090-0163 #15 bar splicers for deck) and stored by IDOT. These shall be supplied by IDOT and installed by the Contractor. Cost is included with Reinforcement Bars, Epoxy Coated.

All dimensions are in millimeters (mm) except as noted.

BAR SPLICER ASSEMBLY DETAILS

Date	Designed TDN	INTERSTATE 74 AND RAMPS L-1 AND L-4 OVER E. WASHINGTON STREET F.A.I. RTE. 74 SECTION (90-14HB)BR TAZEWELL COUNTY STATION 153+868.540 STRUCTURE NO. 090-0163 (WB)	Sheet No.
Revisions	Drawn BKN		23
	Checked DCS		
	Approved KWB		
Prepared By:	URS 3040 North University Avenue Decatur, IL 62526		