

F.A. RTE.	SECTION	COUNTY	TOTAL SHEETS	SHEET NO.
			1366	1382
STA.		TO STA.		
FED. ROAD DIST. NO.		ILLINOIS FED. AID PROJECT		

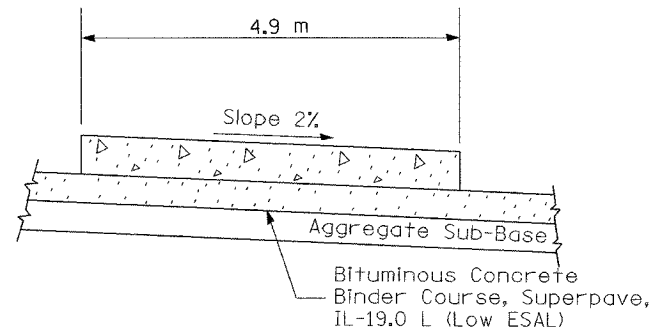

SECTION A-A
(TYPICAL 1-LANE RAMP WITH SHOULDERS)

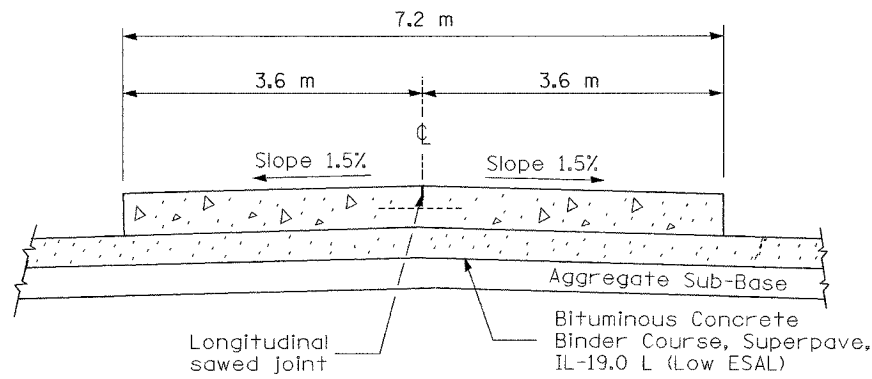

SECTION B-B
(TYPICAL 2-LANE RAMP WITH SHOULDERS)

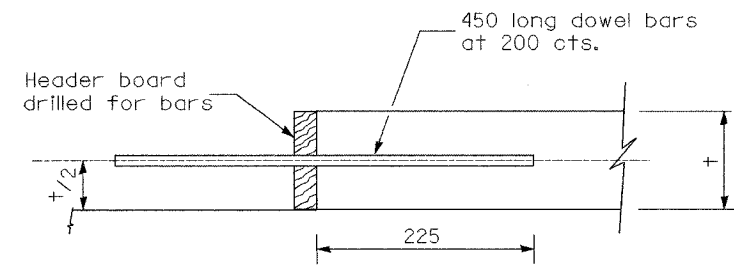

TRANSVERSE CONSTRUCTION JOINT

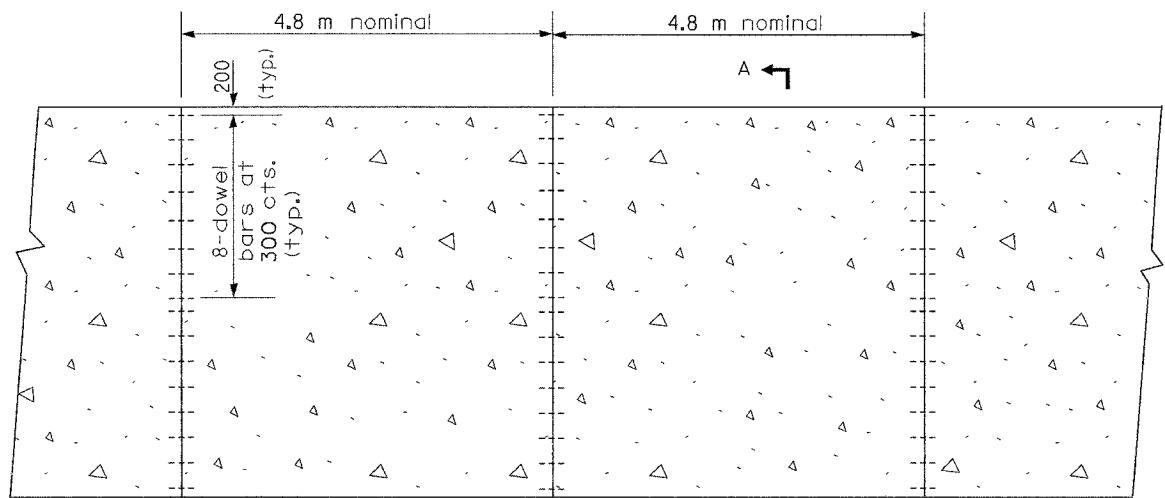

1-LANE RAMP PLAN

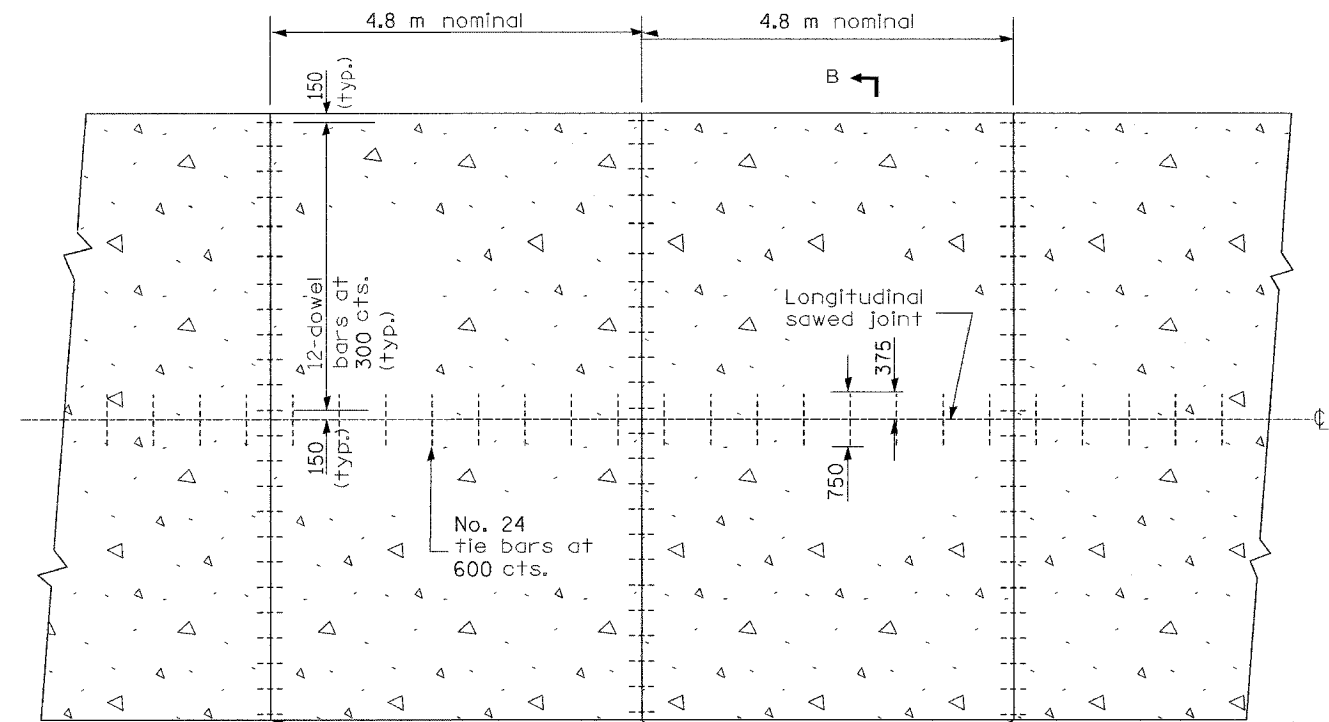

2-LANE RAMP PLAN

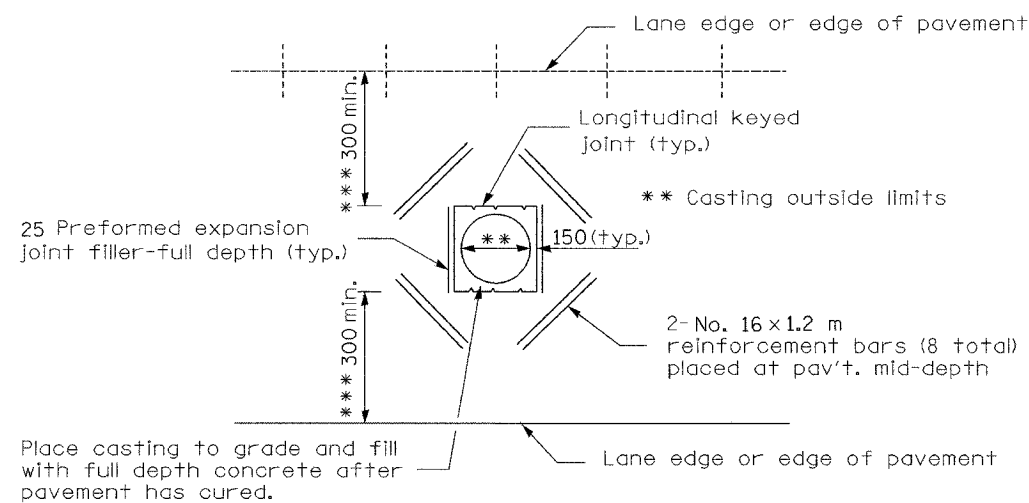

DETAIL OF ADDED REINFORCEMENT FOR PAVEMENT BLOCKS-OUTS

GENERAL NOTES

Details of joints as shown on Standard 420001 except as otherwise shown herein.

All dimensions are in millimeters unless otherwise shown.

SHEET 2 OF 14

A longitudinal sawed joint or a longitudinal construction joint with No. 24 tie bars at 600 cts. shall be provided when the width of ramp pavement exceeds 4.9 m.

*** When the 300 minimum cannot be achieved, the transverse joints shall be extended to either the longitudinal joint or edge of pavement.

REVISIONS	
NAME	DATE
INC. COMMENTS	3/7/02
REM. ENGL.	3/22/02
REM C-JOINT	12/9/02
H.S. 2004	9/26/03

ILLINOIS DEPARTMENT OF TRANSPORTATION
I-74 PROJECT STANDARD 420101-I74
JOINTED PCC PAVEMENT FOR RAMPS

DATE 9/21/01
DRAWN BY
CHECKED BY

CONTRACT I-74 PLAN SET 3 OF 4 FINAL PLANS 1/05