

NOTE:  
BARRIER TRANSITION CENTERED ON HIGH MAST TOWER FOUNDATION.

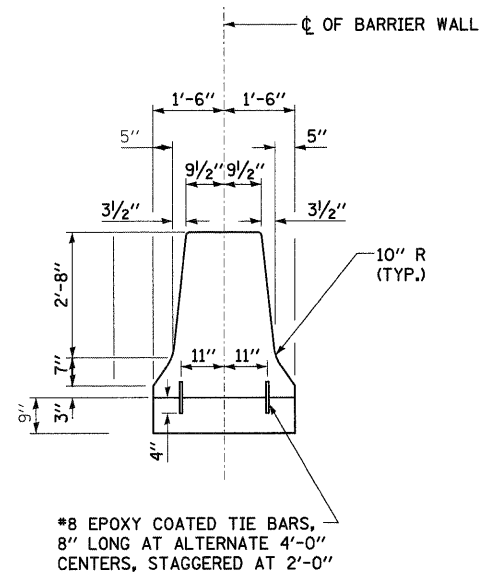

SECTION A-A

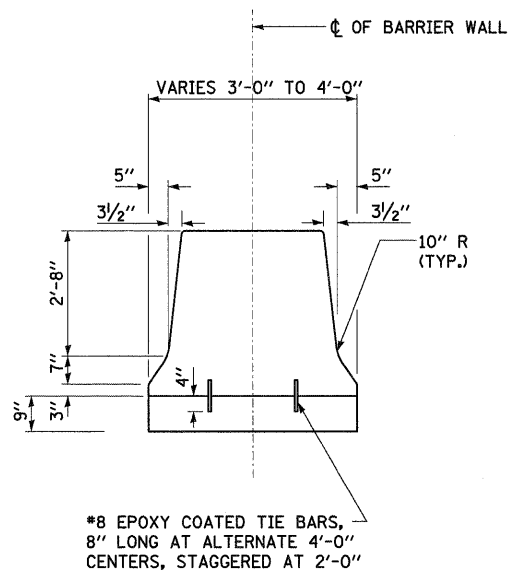

SECTION B-B

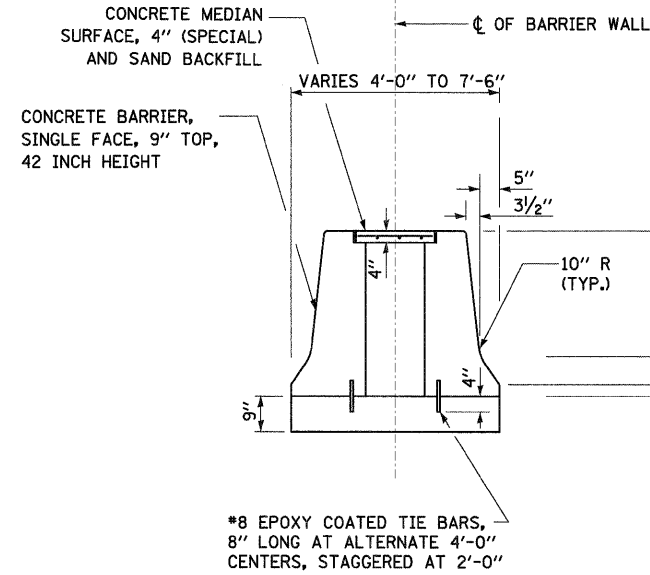

SECTION C-C

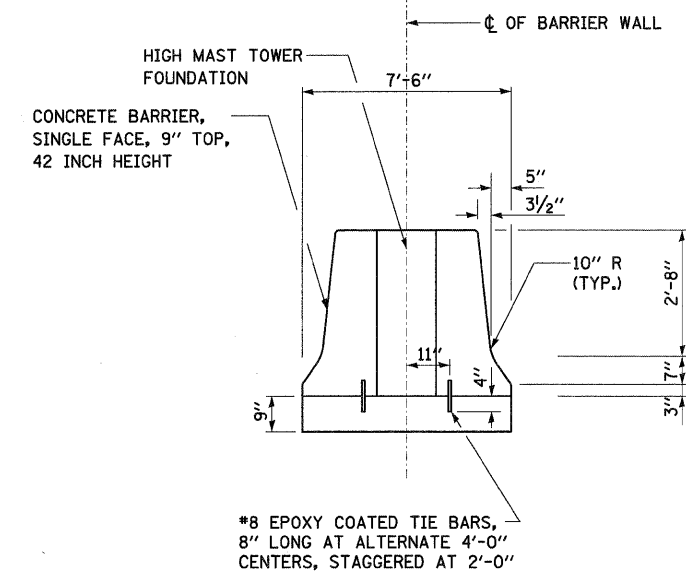

SECTION D-D

FILE NAME = D162F12-SHT-DETAILS-BARRIER.dgn	USER NAME = TKLegal	DESIGNED - BKB	REVISED -	<b>STATE OF ILLINOIS DEPARTMENT OF TRANSPORTATION</b>	<b>BARRIER TRANSITION AT HIGH MAST TOWER DETAIL</b>	F.A.I. RTE. 55	SECTION 99-2HB-2B-1	COUNTY WILL	TOTAL SHEETS 756	SHEET NO. 86	
PLOT SCALE = 1:10.0001	CHECKED - MJL	REVISED -	SCALE:			SHEET NO. 1 OF 1 SHEETS	STA. TO STA.	CONTRACT NO. 60F12			
PLOT DATE = 2/3/2011	DATE - 2/4/11	REVISED -	FED. ROAD DIST. NO. 1 ILLINOIS FED. AID PROJECT								