

ELECTRICAL SERVICE - PANEL DIAGRAM (TYPICAL FOR POLE AND GROUND MOUNTED SERVICE)
SERVICE INSTALLATION POLE MOUNT (SHOWN)
 (NOT TO SCALE)

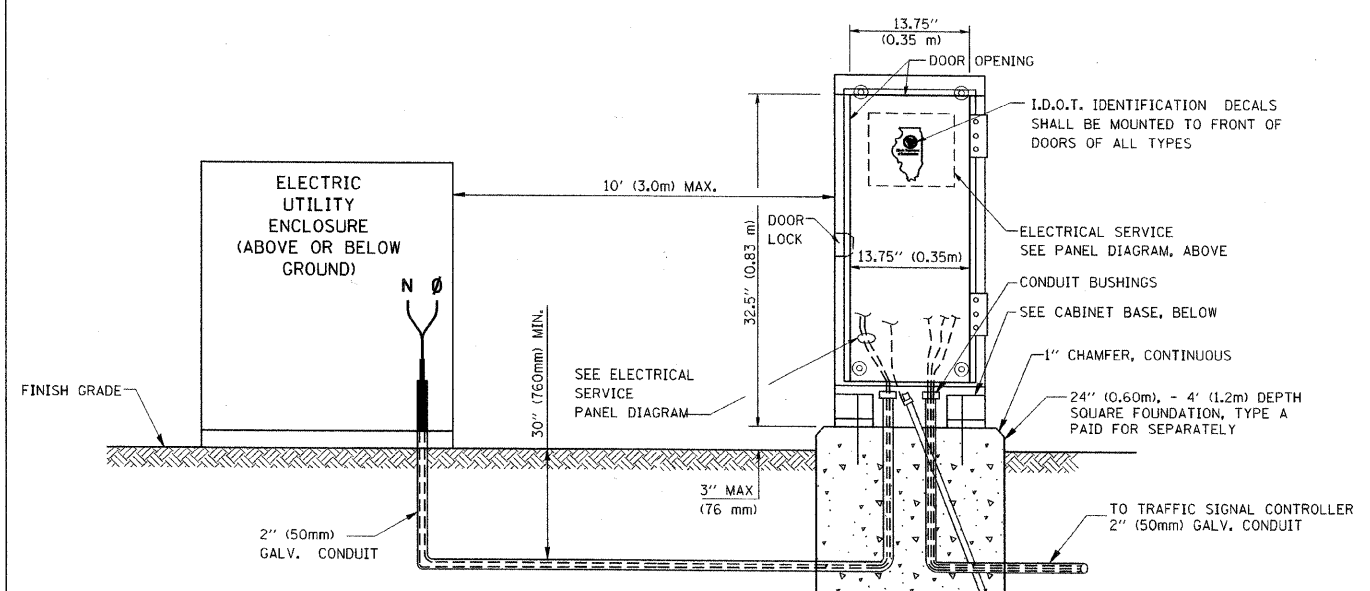

SERVICE INSTALLATION GROUND MOUNT
 (NOT TO SCALE)

CABINET - BASE BOLT PATTERN
 (NOT TO SCALE)

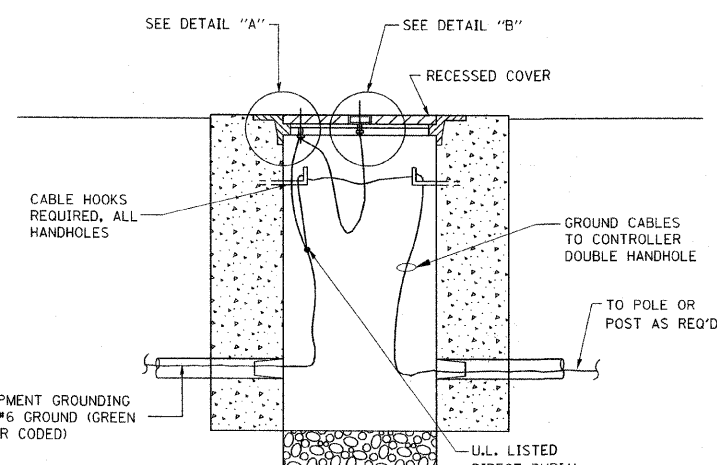
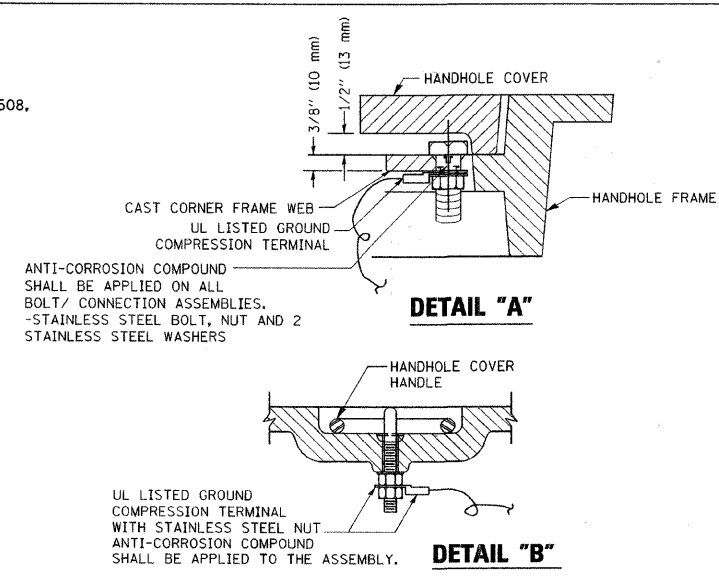
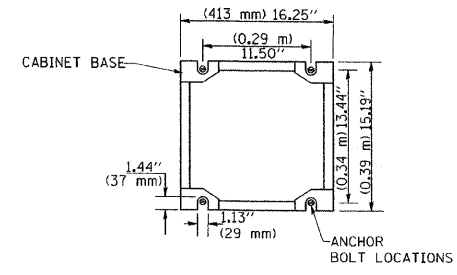

HANDHOLE COVER & FRAME - GROUNDING DETAIL
 (NOT TO SCALE)

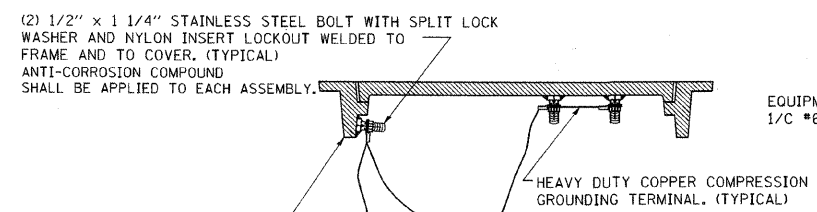

EXISTING HANDHOLE COVER & FRAME - GROUNDING DETAIL
 (NOT TO SCALE)

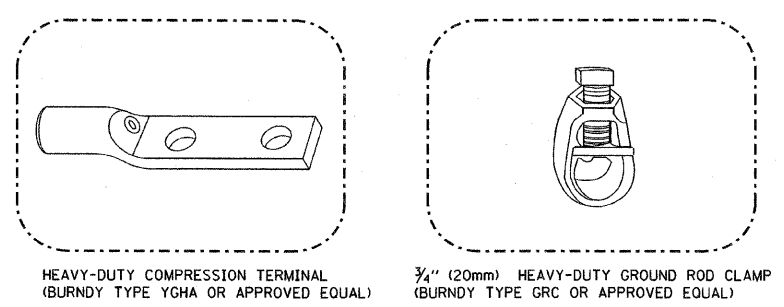

- NOTES:**
- ALL CLAMPS SHALL BE BRONZE OR COPPER, UL APPROVED.
 - GROUND CABLE SHALL BE LOOPED OVER HOOKS IN THE HANDHOLES 6.5' (2.0m) SLACK SHALL BE PROVIDED IN SINGLE HANDHOLES 13' (4.0m) OF SLACK SHALL BE PROVIDED IN DOUBLE HANDHOLES. 5' (1.4m) OF SLACK SHALL BE PROVIDED BETWEEN FRAME AND COVER.

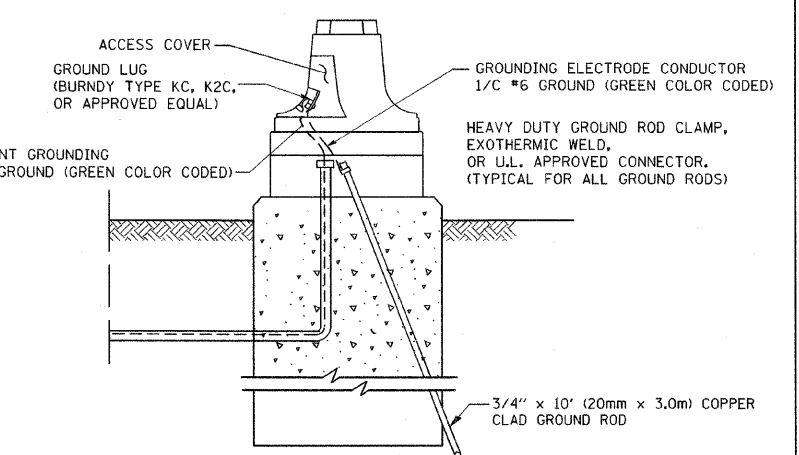

MAST ARM POLE / POST-GROUNDING DETAIL
 (NOT TO SCALE)

FILE NAME =	USER NAME = kanthapxaybc	DESIGNED - DAD	REVISED -
c:\pwork\PWIDOT\KANTHAPHIXAYBC\d01126	4\traffice_legend.v7.dgn	DRAWN - BCK	REVISED -
	PLOT SCALE = 20.0000" / IN.	CHECKED - DAD	REVISED -
	PLOT DATE = 10/6/2009	DATE - 10/28/09	REVISED -

STATE OF ILLINOIS
DEPARTMENT OF TRANSPORTATION

DISTRICT 1
STANDARD TRAFFIC SIGNAL DESIGN DETAILS

SCALE: SHEET NO. 3 OF 6 SHEETS STA. TO STA.

F.A.P. RTE.	SECTION	COUNTY	TOTAL SHEETS	SHEET NO.
336	99-00232-01-WR	KANE	215	164
FED. ROAD DIST. NO. ILLINOIS FED. AID PROJECT			CONTRACT NO. 63541	