

F.A. RTE.	SECTION	COUNTY	TOTAL SHEETS	SHEET NO.
Var. D2 Bridge Painting 2011-2		Various	25	1
	ILLINOIS	CONTRACT NO. 64G88		

STATE OF ILLINOIS
DEPARTMENT OF TRANSPORTATION
DIVISION OF HIGHWAYS

**PROPOSED
HIGHWAY PLANS**

VARIOUS ROUTES
SECTION D2 BRIDGE PAINTING 2011-2

BRIDGE PAINTING
VARIOUS COUNTIES

C-92-071-11

FOR INDEX OF SHEETS, SEE SHEET NO. 2

D-92-044-11

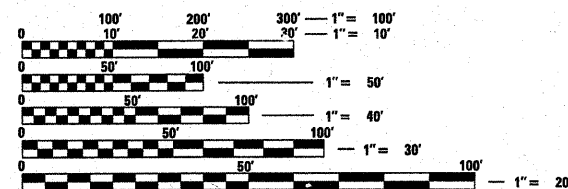
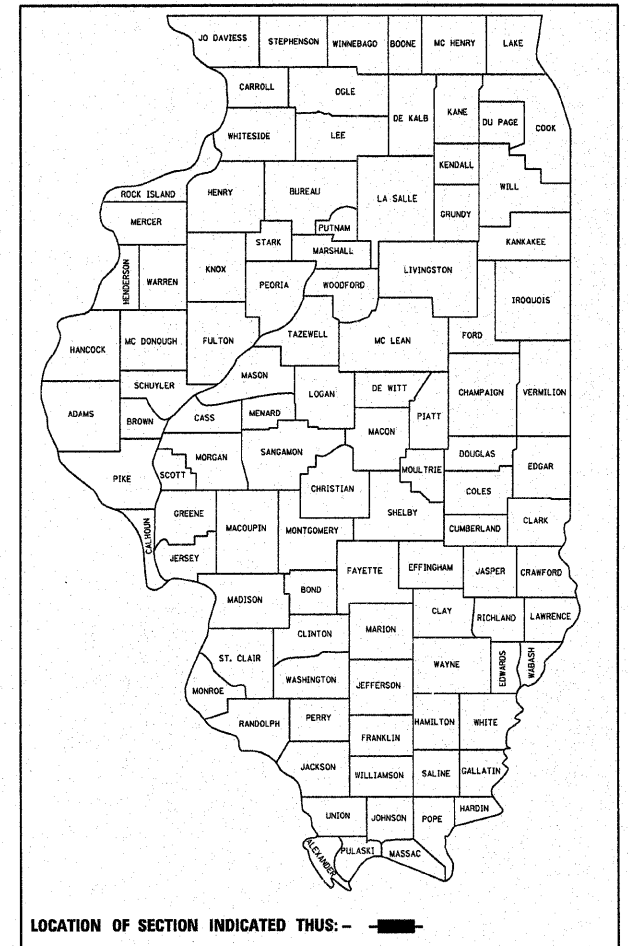

FULL SIZE PLANS HAVE BEEN PREPARED USING STANDARD ENGINEERING SCALES. REDUCED SIZED PLANS WILL NOT CONFORM TO STANDARD SCALES. IN MAKING MEASUREMENTS ON REDUCED PLANS, THE ABOVE SCALES MAY BE USED.

J.U.L.I.E.
JOINT UTILITY LOCATION INFORMATION FOR EXCAVATION
1-800-892-0123
OR 811

BRIDGE MAINTENANCE ENGINEER: Mahmoud Etemadi 815/284-5393
BRIDGE PAINT TECHNICIAN: Dan Link 815/284-5416

CONTRACT NO. 64G88

STATE OF ILLINOIS
DEPARTMENT OF TRANSPORTATION
DIVISION OF HIGHWAYS

SUBMITTED January 27 20 11
Eric S. Thekildang
DEPUTY DIRECTOR OF HIGHWAYS, REGION ENGINEER

March 4 20 11
Scott E. Stitt, P.E. Jr.
acting ENGINEER OF DESIGN AND ENVIRONMENT

March 4 20 11
Christine M. Reed, Jr.
DIRECTOR OF HIGHWAYS, CHIEF ENGINEER

**PRINTED BY THE AUTHORITY
OF THE STATE OF ILLINOIS**

SUMMARY OF QUANTITIES

100% State
0014

PAY ITEM #	DESCRIPTION	UNIT	
50606701	CLEANING AND PAINTING STRUCTURAL STEEL, LOCATION 1	L SUM	1
50606702	CLEANING AND PAINTING STRUCTURAL STEEL, LOCATION 2	L SUM	1
50606703	CLEANING AND PAINTING STRUCTURAL STEEL, LOCATION 3	L SUM	1
50606704	CLEANING AND PAINTING STRUCTURAL STEEL, LOCATION 4	L SUM	1
50606705	CLEANING AND PAINTING STRUCTURAL STEEL, LOCATION 5	L SUM	1
67100100	MOBILIZATION	L SUM	1
70100207	TRAFFIC CONTROL AND PROTECTION, STANDARD 701402	EACH	1
70100700	TRAFFIC CONTROL AND PROTECTION, STANDARD 701406	L SUM	1
70102625	TRAFFIC CONTROL AND PROTECTION, STANDARD 701606	L SUM	1
70102640	TRAFFIC CONTROL AND PROTECTION, STANDARD 701801	L SUM	1
70100450	TRAFFIC CONTROL AND PROTECTION, STANDARD 701201	L SUM	1
70300100	SHORT TERM PAVEMENT MARKING	FOOT	48
70300220	TEMPORARY PAVEMENT MARKING - LINE 4"	FOOT	8400
70301000	WORK ZONE PAVEMENT MARKING REMOVAL	SQ FT	2800
70400100	TEMPORARY CONCRETE BARRIER	FOOT	300
70400200	RELOCATE TEMPORARY CONCRETE BARRIER	FOOT	900
78300100	PAVEMENT MARKING REMOVAL	SQ FT	400
X5060601	CONTAINMENT AND DISPOSAL OF NON-LEAD PAINT CLEANING RESIDUES NO. 1	L SUM	1
X5060602	CONTAINMENT AND DISPOSAL OF NON-LEAD PAINT CLEANING RESIDUES NO. 2	L SUM	1
Z0007101	CONTAINMENT AND DISPOSAL OF LEAD PAINT CLEANING RESIDUES NO. 1	L SUM	1
Z0007102	CONTAINMENT AND DISPOSAL OF LEAD PAINT CLEANING RESIDUES NO. 2	L SUM	1
Z0007103	CONTAINMENT AND DISPOSAL OF LEAD PAINT CLEANING RESIDUES NO. 3	L SUM	1
Z0030250	IMPACT ATTENUATORS, TEMPORARY (NON- REDIRECTIVE), TEST LEVEL 3	EACH	1
Z0030350	IMPACT ATTENUATORS, RELOCATE (NON- REDIRECTIVE), TEST LEVEL 3	EACH	3
X5067501	BRIDGE CLEANING AND PAINTING WARRANTY NUMBER 1	L SUM	1

FILE NAME =	USER NAME = linkdj	DESIGNED -	REVISED -	STATE OF ILLINOIS DEPARTMENT OF TRANSPORTATION	Summary of Quantities D2 Bridge Painting 2010-2	F.A. RTE. =	SECTION	COUNTY	TOTAL SHEETS	SHEET NO.
D:\BR\Brdge Painting\Contracts\PAINTING\64GB8VPLA\eng.dgn	DRAWN -	REVISED -	var D2 Bridge Painting 2011-2			various	25	2		
PLOT SCALE = 50.0000' / IN.	CHECKED -	REVISED -	CONTRACT NO. 64GB8							
PLOT DATE = Sat Jan 22 07:12:27 2011	DATE -	REVISED -	ILLINOIS FED. AID PROJECT							
SCALE: _____ SHEET NO. ___ OF ___ SHEETS STA. _____ TO STA. _____										

GENERAL NOTES

A minimum of 2 air monitors will be required to monitor abrasive blasting operations at each location, see special provision for "Containment and Disposal of Lead Paint Cleaning Residues".

The Contractor shall seed all disturbed areas within the project limits. Seeding Class 4 or 2A shall be used, except in front of properties where the grass will be mowed, then use Seeding, Class 1. Class 2A shall be used on front slopes and ditch bottoms. Class 4 shall be used behind Type A gutter, on all backslopes and areas behind the backslope, and beyond the toe of front slope on fill sections without ditches. This work will be included in the contract unit price per LUMP SUM for CLEANING AND PAINTING STEEL BRIDGE NO. 1.

Fertilizer shall be applied to all disturbed areas and incorporated into the seedbed prior to seeding or placement of sod at the rate specified in Sections 250 and 252 of the Standard Specifications. This work shall be included in the cost of CLEANING AND PAINTING STEEL BRIDGE NO. 1.

Mulch Method II shall be applied over all seeded areas. This shall be included in the cost of the CLEANING AND PAINTING STEEL BRIDGE NO. 1.

The Contractor shall be responsible for protecting utility property during construction operations as outlined in Article 107.31 of the Standard Specifications. A minimum of 48 hours advance notice is required for non-emergency work. The JULIE number is 800-892-0123.

INDEX OF SHEETS

1. Cover Sheet
2. General Notes, Index of Sheets, Standards
3. Summary of Quantities
4. Location Maps
5. Traffic Control Plan Structure 037-0116

Existing Bridge Plans

6. -8. SN 037-0116
9. -12. SN 037-0137
13. -16. SN 037-0138
17. -22. SN 089-0042
23. -25. SN 101-0003

STANDARDS

- 701006-03 Off-Road Operations, 2L, 2W, 15' (4.5 m) to 24" (600 mm) From Pavement Edge
- 701101-02 Off-Road Operations, Multilane, 15' (4.5 m) to 24" (600 mm) From Pavement Edge
- 701301-04 Lane Closure, 2L, 2W, Short Time Operations
- 701400-05 Approach to Lane Closure, Freeway/Expressway
- 701402-08 Lane Closure, Freeway/Expressway, with Barrier
- 701406-06 Lane Closure, Freeway/Expressway, Day Operations Only
- 701606-07 Urban Lane Closure, Multilane, 2W with Mountable Median
- 701801-04 Lane Closure, Multilane 1W or 2W Crosswalk or Sidewalk Closure
- 701901-01 Traffic Control Devices
- 704001-06 Temporary Concrete Barrier
- 720011-01 Metal Posts for Signs, Markers and Delineators
- 728001-01 Telescoping Steel Sign Support
- 729001-01 Applications of Types A and B Metal Posts (For Signs & Markers)

FILE NAME =	USER NAME = linkdj	DESIGNED -	REVISD -	STATE OF ILLINOIS DEPARTMENT OF TRANSPORTATION	General Notes, Index of Sheets, Standards	F.A. RTE.	SECTION	COUNTY	TOTAL SHEETS	SHEET NO.	
D:\BR\Bridge Painting\Contracts\PAINTING\64C88\PL ANeng.dgn		DRAWN -	REVISD -			var	D2 Bridge Painting 2011-2	various	25	3	
	PLOT SCALE = 50.0000' / IN.	CHECKED -	REVISD -			CONTRACT NO. 64C88					
	PLOT DATE = Sat Jan 22 07:12:20 2011	DATE -	REVISD -			ILLINOIS FED. AID PROJECT					

LOCATION MAPS

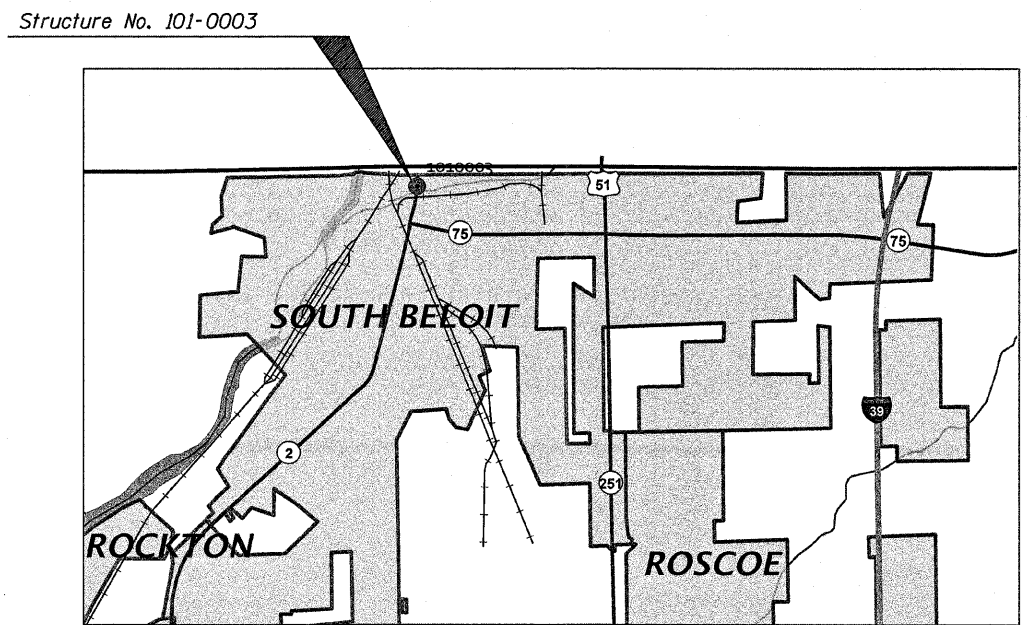
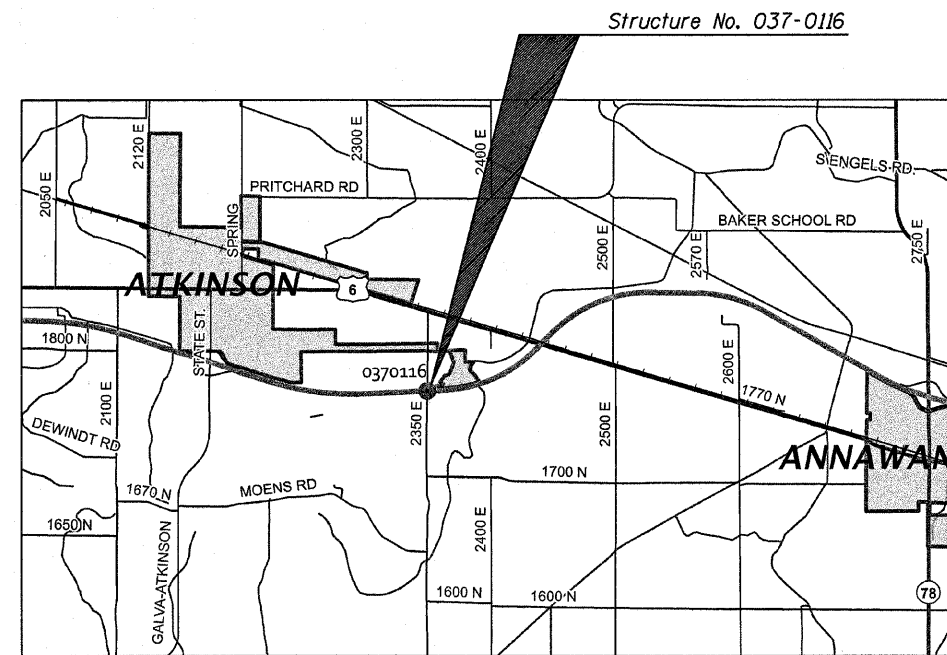
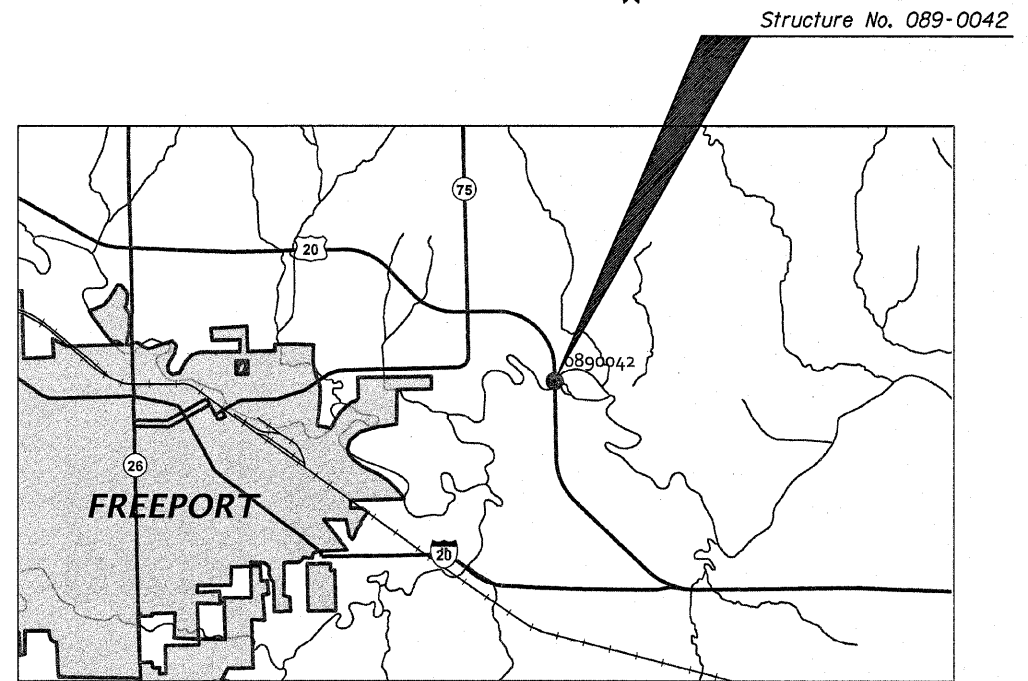
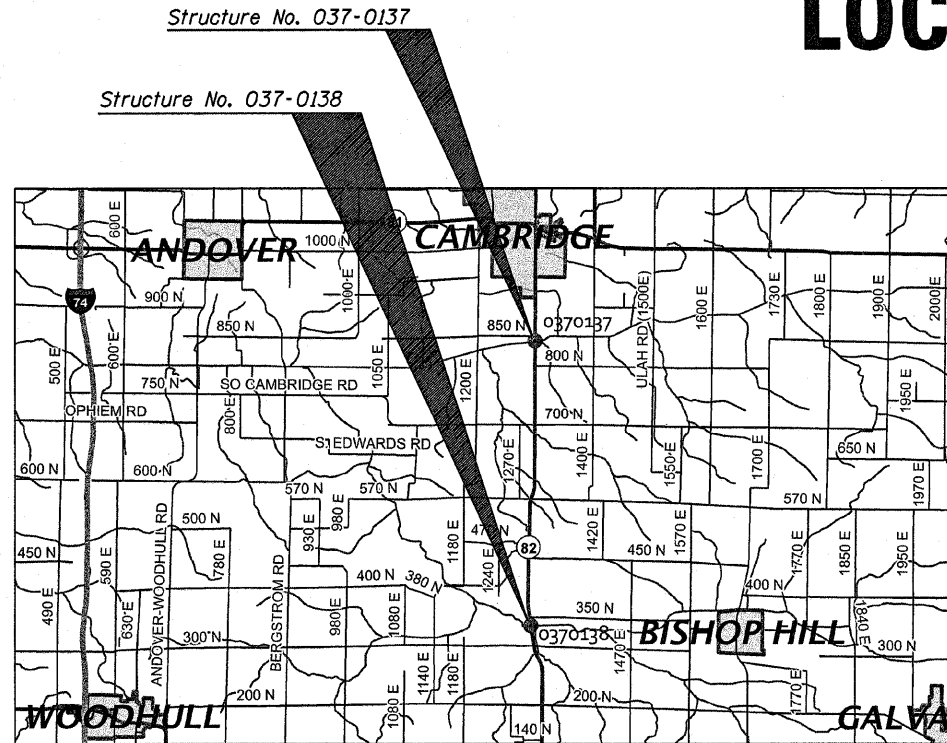

FILE NAME =	USER NAME = linkdj	DESIGNED -	REVISED -
C:\BR\Bridg Painting\Contract\PAINTING\64C88\PLAN\dgn		DRAWN -	REVISED -
	PLOT SCALE = 50.0000' / IN.	CHECKED -	REVISED -
	PLOT DATE = Sat Jan 22 07:12:16 2011	DATE -	REVISED -

**STATE OF ILLINOIS
DEPARTMENT OF TRANSPORTATION**

**Location Maps
D2 Bridge Painting 2011-2**

SCALE: _____ SHEET NO. ___ OF ___ SHEETS STA. _____ TO STA. _____

F.A. RTE.	SECTION	COUNTY	TOTAL SHEETS	SHEET NO.
var	D2 Bridge Painting 2011-2	Various	25	4
			CONTRACT NO. 64C88	
ILLINOIS FED. AID PROJECT				

Traffic Control Plan

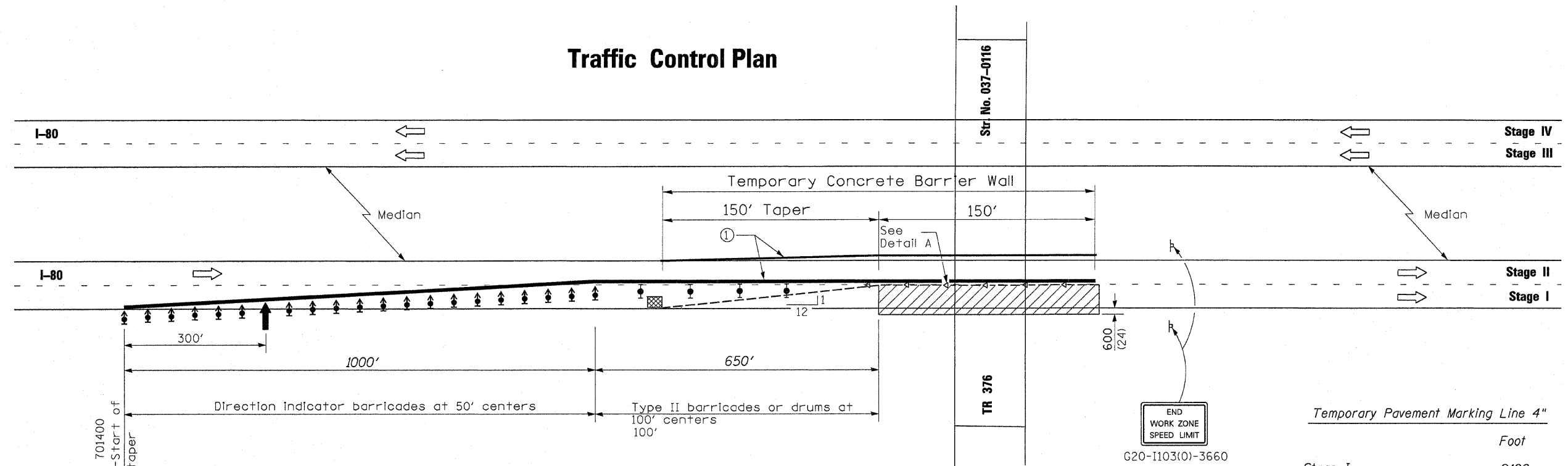

Pavement Marking Removal

Stage I	100
Stage II	100
Stage III	100
Stage IV	100
Total	400 Sq Ft

Relocate Temporary Concrete Barrier

Stage I	300 Feet
Total	300 Feet

Stage II	300
Stage III	300
Stage IV	300
Total	900

Impact Attenuators, Temporary

Stage I	1 Each
Total	1 Each

Impact Attenuators, Relocate

Stage II	1
Stage III	1
Stage IV	1
Total	3 Each

Temporary Pavement Marking Line 4"

Stage I	2100
Stage II	2100
Stage III	2100
Stage IV	2100
Total	8400 Foot

Workzone Pavement Marking Removal

Stage I	700
Stage II	700
Stage III	700
Stage IV	700
Total	2800 Sq Ft

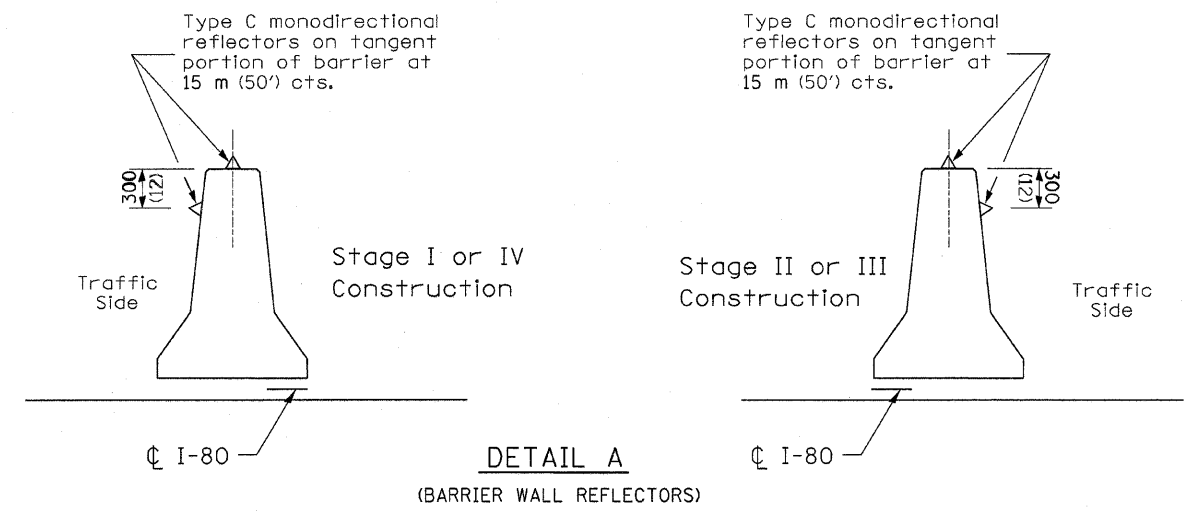

- SYMBOLS**
- ↑ Arrow board
 - ▨ Work area
 - ⊥ Sign
 - ⬆ Direction indicator barricade with steady burn monodirectional light
 - ⬇ Type II barricade or drum with steady burn monodirectional light
 - Temporary concrete barrier
 - ◁ Type C Monodirectional reflector
 - ▣ Impact attenuator

① Temporary pavement marking shall be placed throughout the taper and along-side the work area. The edge line shall be white for right lane closure and yellow for left lane closures.

All dimensions are in millimeters (inches) unless otherwise shown.

*Traffic Control Plan
TR 376 over I-80
Various Routes Section D2 Bridge Painting 2011-2
Various Counties
Structure No. 037-0116*

FILE NAME =	USER NAME = linkdj	DESIGNED -	REVISED -	STATE OF ILLINOIS DEPARTMENT OF TRANSPORTATION	Traffic Control Plan Structure 037-0116		F.A. RTE.	SECTION	COUNTY	TOTAL SHEETS	SHEET NO.
D:\BR\Bridge Painting\Contracts\PAINTING\64G88\PLAN\eng.dgn	54G88\PLAN\eng.dgn	DRAWN -	REVISED -		var	D2 Bridge Painting 2011-2	Various	25	5		
PLOT SCALE = 50.0000' / IN.		CHECKED -	REVISED -		SCALE: _____ SHEET NO. ____ OF ____ SHEETS STA. _____ TO STA. _____		CONTRACT NO. 64G88				
PLOT DATE = Sat Jan 22 07:11:47 2011		DATE -	REVISED -		ILLINOIS FED. AID PROJECT						

STATE OF ILLINOIS
DEPARTMENT OF PUBLIC WORKS & BUILDINGS
DIVISION OF HIGHWAYS

PROJECT NO.	SECTION	COUNTY	TOTAL SHEETS	SHEET NO.
118-00	EMB-2	Henry	25	4

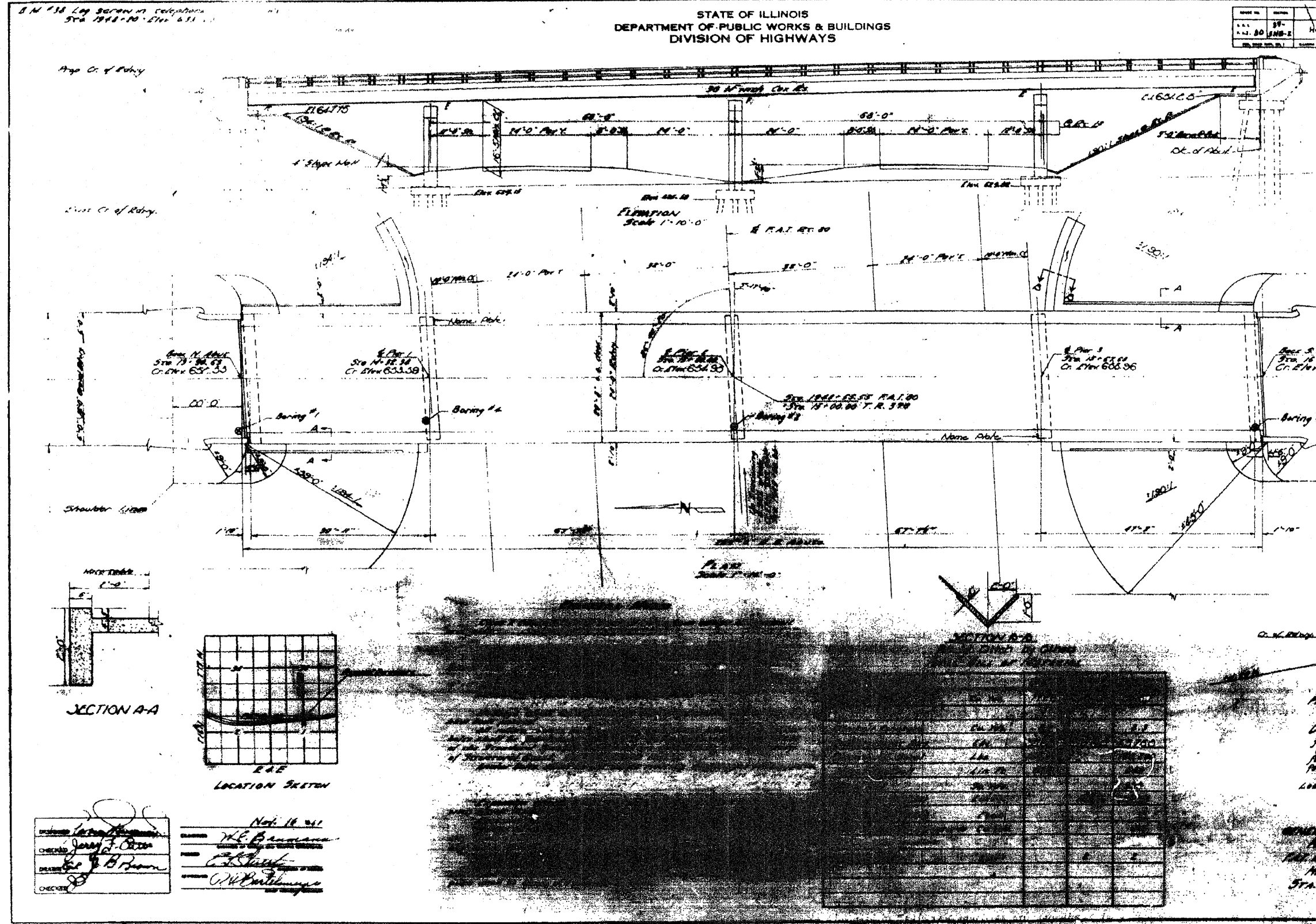

STATION 1948+38.35
BUILT 1904 BY
STATE OF ILLINOIS
GREENWOOD BRIDGE CO.
LOADING H-15-S16

NONE PLATE
(See Std. 110)

DESIGN STANDARDS
10 - Max. Ht. Super
14 - 17' Ht. Paving
14 - Spacing of Truss
14 - Max. Ht. Street
H-15
LOADING H-15-S16-S1

GENERAL PLAN (SEE DRAWING)
FIELD PLAN (SEE DRAWING)
THE STATE OF ILLINOIS
HENRY COUNTY
STA. 1948+38.35

FOR INFORMATION ONLY

FILE NAME =	USER NAME = linkdj	DESIGNED -	REVISED -	STATE OF ILLINOIS DEPARTMENT OF TRANSPORTATION	Existing Bridge Plans Structure 037-0116	F.A. RTE. =	SECTION	COUNTY	TOTAL SHEETS	SHEET NO.
D:\BR\Bridge Painting\Contracts\PAINTING\64088\PLA\eng.dgn	64088\PLA\eng.dgn	DRAWN -	REVISED -			var 02 Bridge Painting 2011-2	Various	25	6	
PLOT SCALE = 50.0000' / IN.		CHECKED -	REVISED -			CONTRACT NO. 64088				
PLOT DATE = Sat Jan 22 07:11:41 2011		DATE -	REVISED -			ILLINOIS FED. AID PROJECT				

STATE OF ILLINOIS
DEPARTMENT OF PUBLIC WORKS & BUILDINGS
DIVISION OF HIGHWAYS

DATE	BY	CHECKED	SCALE	SHEET NO.
11-20-03	Henry	23	5	8 SHEETS

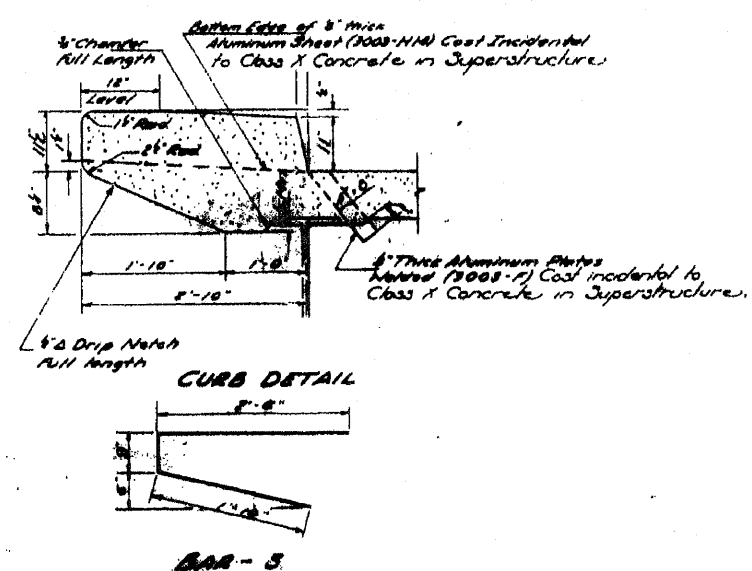
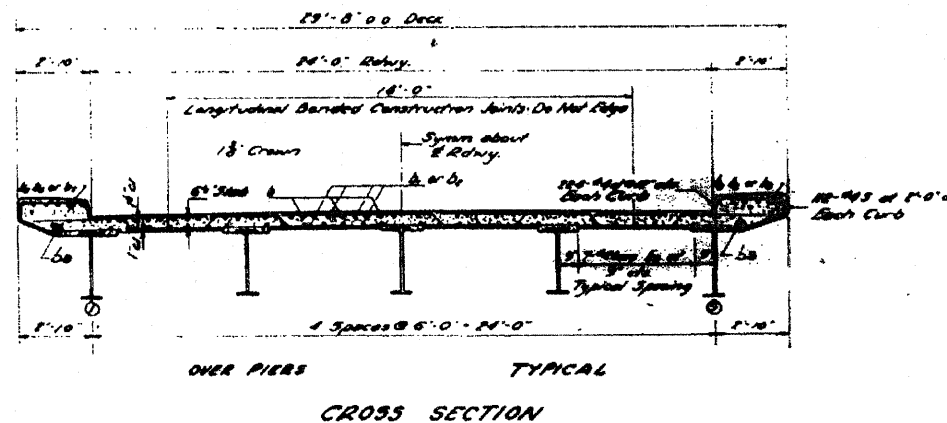
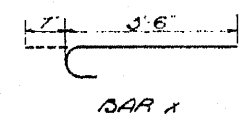
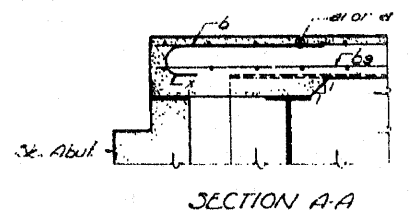
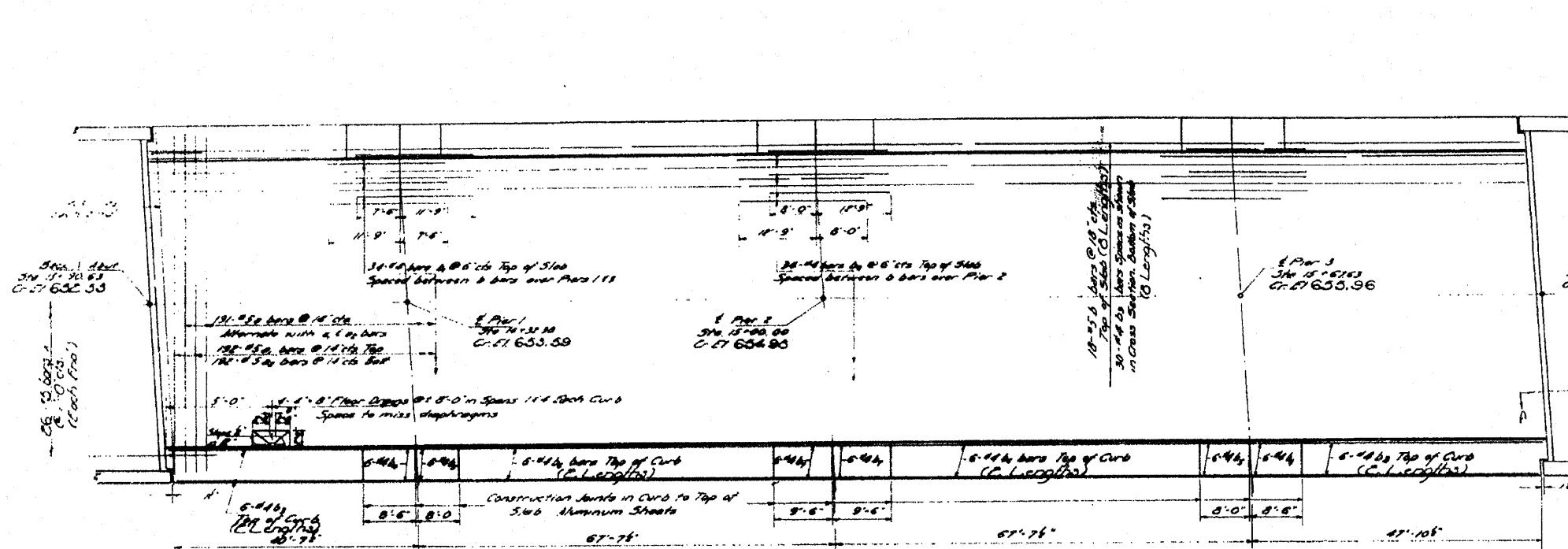

BILL OF MATERIAL

Bar	No	Size	Length	Shape
1	181	#5	28'0"	---
2	184	#5	28'0"	---
3	184	#5	28'0"	---
4	188	#5	28'0"	---
5	68	#4	19'9"	---
6	34	#4	20'8"	---
7	44	#4	16'5"	---
8	24	#4	8'5"	---
9	24	#4	7'8"	---
10	48	#4	27'6"	---
11	24	#4	8'5"	---
12	24	#4	20'8"	---
13	240	#4	---	---
14	44	#4	18'0"	---
15	24	#4	8'5"	---
16	24	#4	---	---
17	24	#4	---	---
18	24	#4	---	---
19	24	#4	---	---
20	24	#4	---	---
21	24	#4	---	---
22	24	#4	---	---
23	24	#4	---	---
24	24	#4	---	---
25	24	#4	---	---
26	24	#4	---	---
27	24	#4	---	---
28	24	#4	---	---
29	24	#4	---	---
30	24	#4	---	---
31	24	#4	---	---
32	24	#4	---	---
33	24	#4	---	---
34	24	#4	---	---
35	24	#4	---	---
36	24	#4	---	---
37	24	#4	---	---
38	24	#4	---	---
39	24	#4	---	---
40	24	#4	---	---
41	24	#4	---	---
42	24	#4	---	---
43	24	#4	---	---
44	24	#4	---	---
45	24	#4	---	---
46	24	#4	---	---
47	24	#4	---	---
48	24	#4	---	---
49	24	#4	---	---
50	24	#4	---	---
51	24	#4	---	---
52	24	#4	---	---
53	24	#4	---	---
54	24	#4	---	---
55	24	#4	---	---
56	24	#4	---	---
57	24	#4	---	---
58	24	#4	---	---
59	24	#4	---	---
60	24	#4	---	---
61	24	#4	---	---
62	24	#4	---	---
63	24	#4	---	---
64	24	#4	---	---
65	24	#4	---	---
66	24	#4	---	---
67	24	#4	---	---
68	24	#4	---	---
69	24	#4	---	---
70	24	#4	---	---
71	24	#4	---	---
72	24	#4	---	---
73	24	#4	---	---
74	24	#4	---	---
75	24	#4	---	---
76	24	#4	---	---
77	24	#4	---	---
78	24	#4	---	---
79	24	#4	---	---
80	24	#4	---	---
81	24	#4	---	---
82	24	#4	---	---
83	24	#4	---	---
84	24	#4	---	---
85	24	#4	---	---
86	24	#4	---	---
87	24	#4	---	---
88	24	#4	---	---
89	24	#4	---	---
90	24	#4	---	---
91	24	#4	---	---
92	24	#4	---	---
93	24	#4	---	---
94	24	#4	---	---
95	24	#4	---	---
96	24	#4	---	---
97	24	#4	---	---
98	24	#4	---	---
99	24	#4	---	---
100	24	#4	---	---

* Height of Rollers, Beams, Bearing Plates, Lead Plates and Anchor Bolts included as Structural Steel Est. Mt. = 6300 lbs.

SUPERSTRUCTURE
FAT. RT. 80' SEC. 111111-1
HENRY COUNTY
STA. 1948+58.55

FOR INFORMATION ONLY

FILE NAME =	USER NAME = linkdj	DESIGNED -	REVISED -	STATE OF ILLINOIS DEPARTMENT OF TRANSPORTATION	Existing Bridge Plans Structure No. 037-0116	F.A. RTE.:	SECTION	COUNTY	TOTAL SHEETS	SHEET NO.
0:\BR\Bridge Painting\Contracts\PAINTING\64088\PLA\eng.dgn	64088\PLA\eng.dgn	DRAWN -	REVISED -			var D2 Bridge Painting 2011-2	Various	25	7	
PLOT SCALE = 50.0000' / IN.	CHECKED -	REVISED -	REVISED -			SCALE: _____	SHEET NO. _____ OF _____ SHEETS	STA. _____ TO STA. _____	ILLINOIS FED. AID PROJECT	
PLOT DATE = Sat Jan 22 07:11:32 2011	DATE -	REVISED -	REVISED -			64088				

STATE OF ILLINOIS
DEPARTMENT OF TRANSPORTATION

ROUTE NO.	SECTION	QUANTITY	DATE	SHEET NO.
VAR. *	VARIOUS	25	B	SHEETS

02 Bridge Painting 2011-2

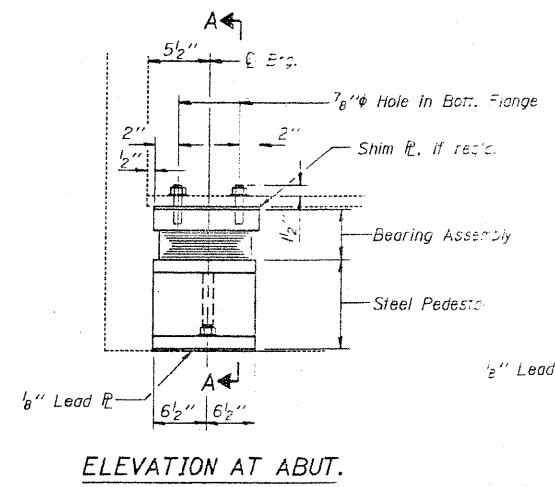

ELEVATION AT ABUT.

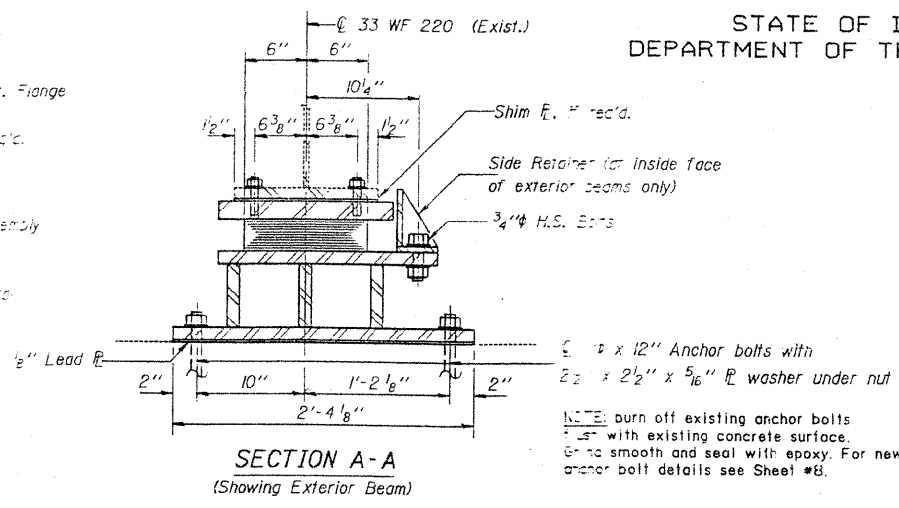

SECTION A-A
(Showing Exterior Beam)

TYPE I ELASTOMERIC EXP. BRG.

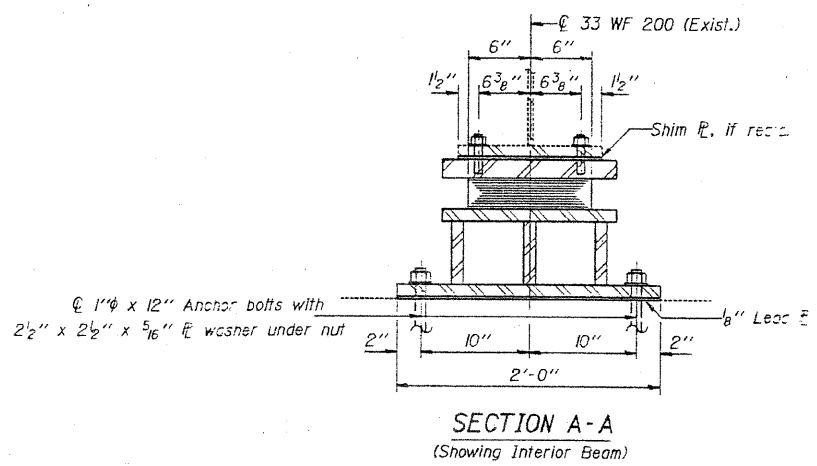

SECTION A-A
(Showing Interior Beam)

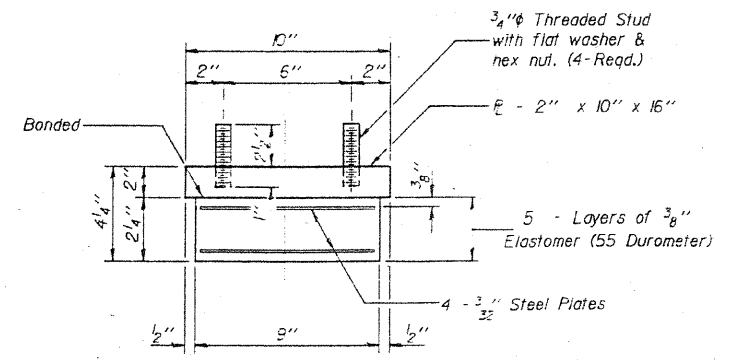

BEARING ASSEMBLY

Note: Shim plates shall not be placed under Bearing Assembly.

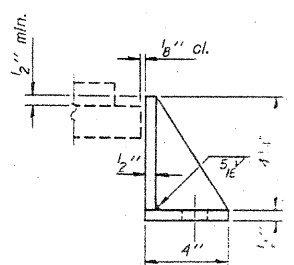

SIDE RETAINER

Equivalent rolled angle with stiffeners will be allowed in lieu of welded plates.

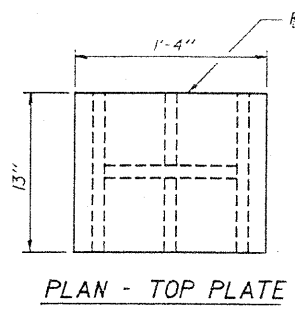

PLAN - TOP PLATE

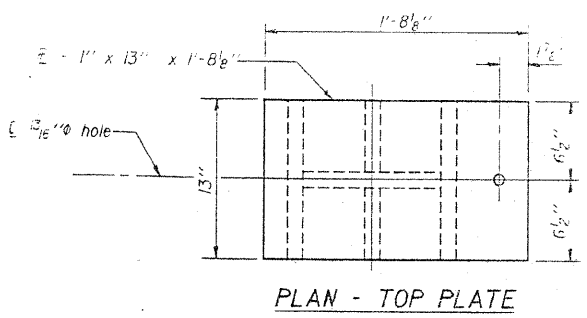

PLAN - TOP PLATE

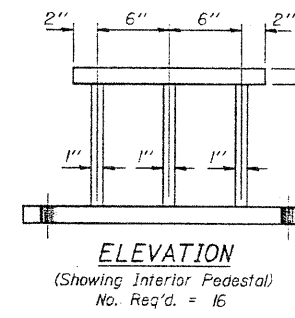

ELEVATION
(Showing Interior Pedestal)
No. Req'd. = 16

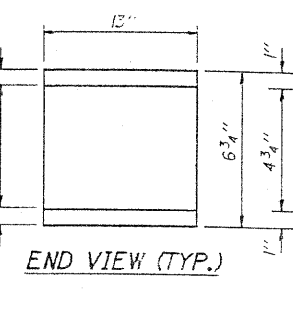

END VIEW (TYP.)

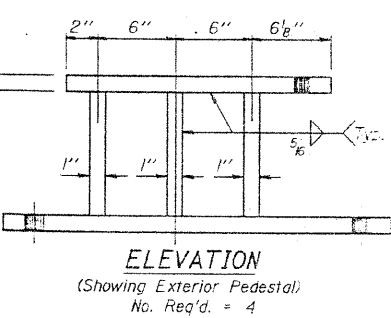

ELEVATION
(Showing Exterior Pedestal)
No. Req'd. = 4

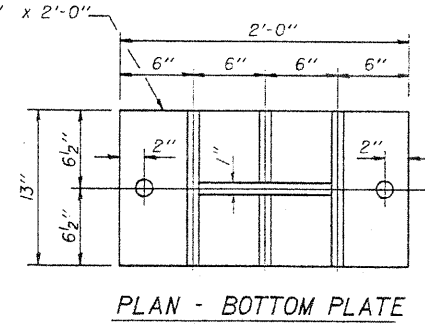

PLAN - BOTTOM PLATE

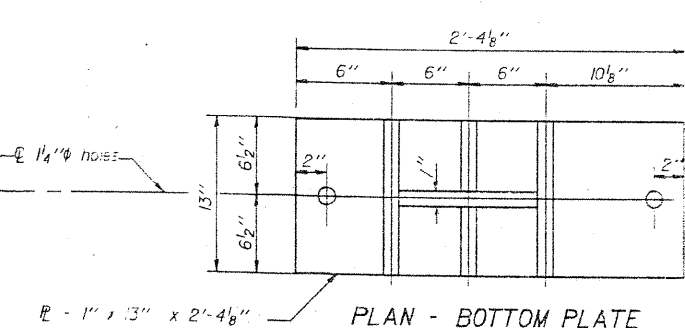

PLAN - BOTTOM PLATE

STEEL PEDESTALS

BEAM REACTIONS

Live Load	39.0 kips
Dead Load	33.5 kips
Impact	10.0 kips

BILL OF MATERIAL

Item	Unit	Qty
Elastomeric Bearing Assembly Type 1	Each	20
Furnishing and Erecting Structural Steel	Lbs.	4500
Jacking and Cribbing	Each	20

NORTH AND SOUTH ABUTMENTS

ELASTOMERIC BEARINGS
F.A. RT. 734 SEC. 76 BR
WINNEBAGO COUNTY
STA. 5 + 89.82

DESIGNED <i>H. H. P.</i>	EXAMINED
CHECKED <i>Rick Bruner</i>	PASSED
DRAWN <i>r. b. carbone</i>	APPROVED
CHECKED <i>KPS RAE</i>	

I-2-EI 12-1-83

DM - CDISE120 10-2-W WIDGMAH - ELEV 112.17
 Existing bridge - 3 span w/4 R.C. Deck girders in each span.
 Solid concrete abutments and 2 solid concrete piers.
 Reinforcing concrete slab w/4" R.C. wearing surface and
 2" asphalt overlay. SN-037-0095 No Salvage.

FOR INFORMATION ONLY

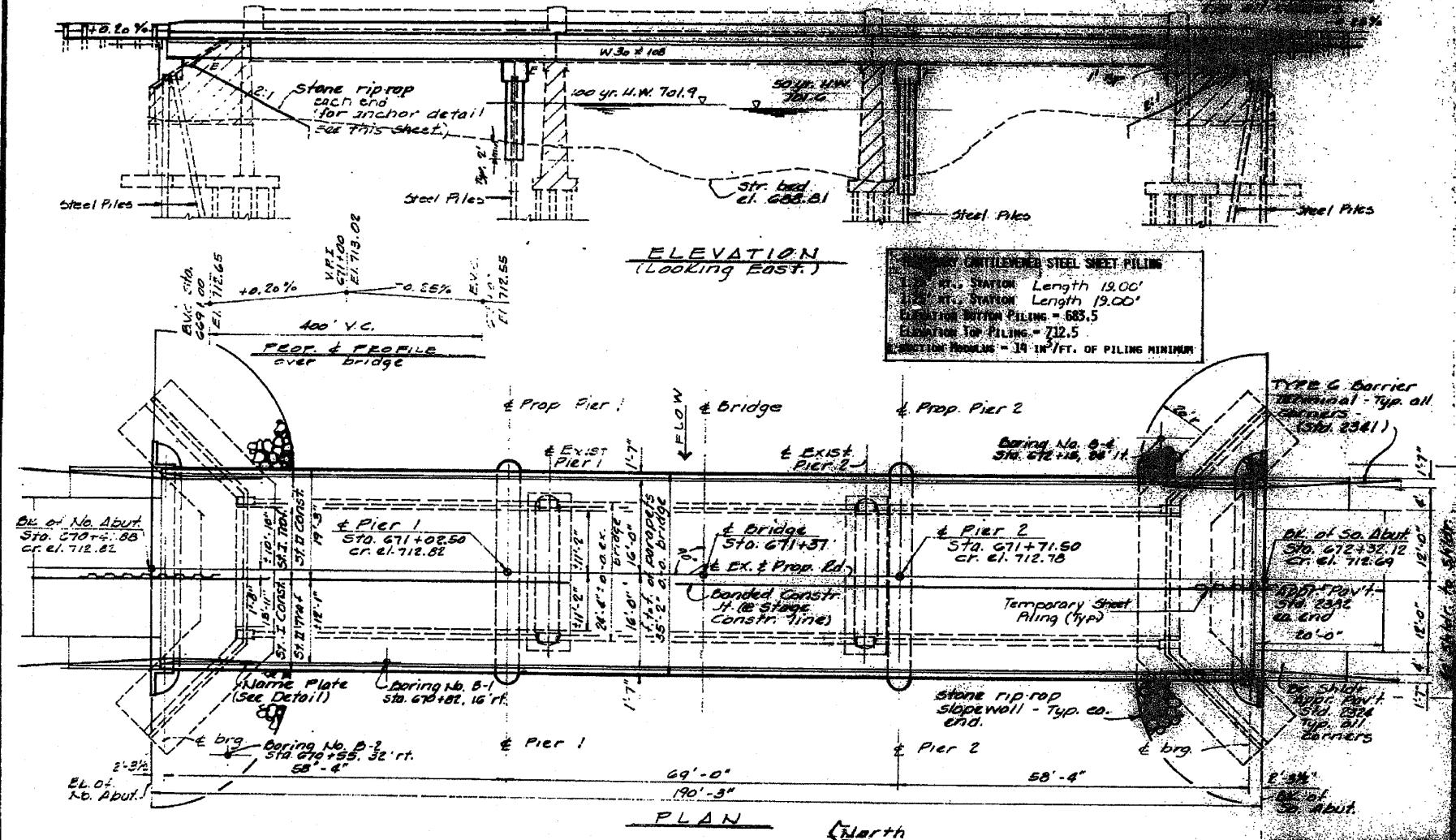

THE CONTRACTOR SHALL DRIVE ONE (1) STEEL PILE BEHIND EACH LOCATION AT PIER 1 AND ONE (1) STEEL PILE BEHIND EACH LOCATION AT PIER 2 AS INDICATED BY THE THE DIMENSIONS SHOWN THE DIMENSIONS OF THE PILE.

LAYOUT OF THE STEEL RIPPAP SHALL BE SHOWN IN THE PLAN VIEW THE EXISTING BRIDGE CONSIDERING AS DESCRIBED BY THE CONTRACT REQUIREMENTS SHALL CONFORM TO THE REQUIREMENTS OF AASHTO N-11, N-12 AND N-23, BRIDGE 10.

BEARING SURFACES SHALL BE CONSTRUCTED OR ADJUSTED TO THE INDICATED ELEVATIONS WITHIN A TOLERANCE OF 1/8" INCH. ADJUSTMENTS SHALL BE MADE BY GRINDING THE SURFACE OR BY OTHER MEANS FOR 24 HOURS ADJUSTING SURFACES, OF THE DIMENSIONS OF THE BEARING PLATE SHALL BE PROVIDED FOR EACH BEARING IN ADDITION TO THE PLATES SHOWN. FOR THE TYPE I ELASTOMERIC BEARINGS, THE DIMENSIONS OF THE TOP PLATE SHALL BE PROVIDED AND THE FASTENERS SHALL BE HIGH-STRENGTH BOLTS. BOLTS SHALL BE 3/4" OVER DIAMETER (1 1/8" DIA.) UNLESS OTHERWISE NOTED ON THE PLANS CONFORM TO THE REQUIREMENTS OF AASHTO N-164.

THE ZINC-SILICATE AND VINYL PAINT SYSTEM SHALL BE USED FOR THE AND THE FIELD PAINTING OF STRUCTURAL STEEL EXCEPT WHERE NOTED.

FIELD WELDING OF CONSTRUCTION ACCESSORIES WILL NOT BE PERMITTED THE BOTTOM FLANGES OF THE BEAMS NEAR TO THE TOP FLANGES OF THE A DISTANCE EQUAL TO 1/3 THE SPAN LENGTH EACH WAY FROM THE SUPPORTS. FIELD WELDING IN OTHER AREAS WILL BE PERMITTED WITH THE APPROVAL OF THE ENGINEER.

ANCHOR BOLTS SHALL BE SET BEFORE BOLTING DIAPHRAGMS OVER THE STRUCTURAL STEEL BEARING PLATES OF THE ELASTOMERIC BEARINGS ACCESSORIES SHALL CONFORM TO THE REQUIREMENTS OF AASHTO N-164.

THE MAIN LOAD CARRYING MEMBER COMPONENTS SUBJECT TO TENSILE SHALL CONFORM TO THE STRUCTURAL REQUIREMENTS FOR NOTCH TENSILE ZONE 2. THESE COMPONENTS ARE THE WIDE FLANGE BEAMS AND ALL PLATE MATERIAL OF THE BEAMS.

CALCULATED WEIGHT OF THE STRUCTURAL STEEL:
 11,185 = 153,030 lb.
 11,185 x 4.50 = 642 lb.

The information shown for the Temporary Sheet Piling is estimated and it is the contractor's responsibility to provide a sufficient amount of the Temp. Sheet Piling & associated members, if any, subject to the approval of the Engineer.

WATERWAY INFORMATION
 Drainage Area - 43.42 sq. mi. Low grade elev. - 710.68 @ Sta. 660+68

Flood	Freq. Yr.	Opening - 3 ft. Nat.		Head w/ Headwater Elev.					
		EXIST.	PROP.	H.W.E.	EXIST. Prop.	EXIST. Prop.			
Design	50	4289	971	1019	701.6	0.60	0.42	702.20	702.02
Base	100	4899	1016	1068	701.9	0.88	0.68	702.78	702.53
Overlapping									
Max. calc.	500	6304		1155	702.3		1.20		703.50

DESIGN SPECIFICATIONS

fc	5000 psi
f _y (rebar)	60000 psi
E _s (steel)	29,000,000 psi (AASHTO M301)
E _c (concrete)	4,000,000 psi (AASHTO M301)

Design Specs - Refer to Plans and Specifications for details.

APPROVED
 FOR STRUCTURAL ADEQUACY ONLY
James J. [Signature]

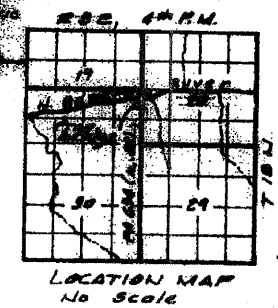

GENERAL PLAN & ELEVATION

PROJECT:
 ROUTE 70-634 (IL 82)
 SECTION: 2003N-1, over North Branch of
 [River Name]
 COUNTY: MERRY
 STATIONING: 671+37

Route	Section	County	Plan	Sta. No.
FA 634	138R-1	HENRY	98	73
Station 671+37				
Bridge Sheet 4 of 29 sheets				

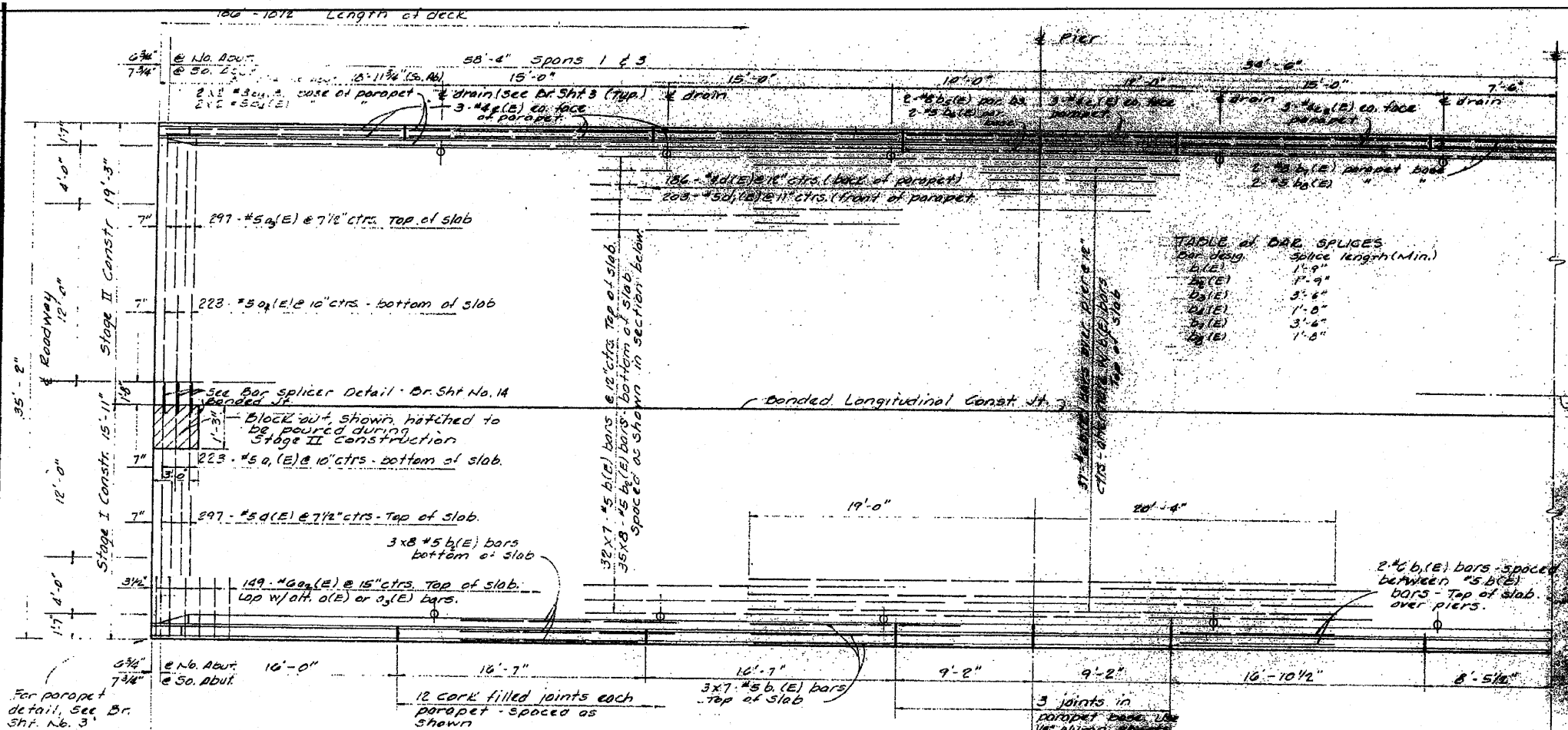

REINFORCEMENT BARS DESIGNATED BY (E) SHALL BE USED UNLESS OTHERWISE SPECIFIED.
 DESIGNATED #5 (E) INDICATES 32 LINES WITH LENGTHS OF BAR IN EACH LINE. THIS LENGTH APPLIES TO ALL BARS DESIGNATED BY A NUMBER DESIGNATION.
 REINFORCEMENT BILL OF MATERIALS, SEE BRIDGE SHEET NO. 13.
 PARAPET AND BRUSH-TRIMMALS, SEE BRIDGE SHEET NO. 13.
 EXPANSION JOINT DETAILS, SEE BRIDGE SHEET NO. 13.

TABLE of BAR SPLICES

Bar Design.	Splice Length (Min.)
D1(E)	1'-9"
B2(E)	1'-9"
D3(E)	3'-6"
D4(E)	1'-0"
D5(E)	3'-6"
D6(E)	1'-0"

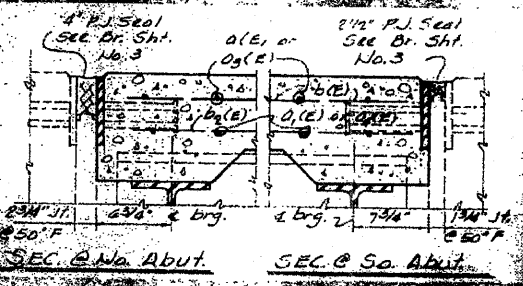

HALF PLAN - DECK
 (Symm. about $\frac{1}{2}$ of bridge & roadway, except as noted.)

BAR LIST - SUPERSTRUCTURE

Bar No.	Size	Length	Shape
297	#5	18'-8"	
223	#5	18'-8"	
298	#6	8'-0"	
299	#5	17'-8"	
275	#5	17'-8"	
266	#5	26'-9"	
70	#6	59'-0"	
328	#5	23'-2"	
76	#8	20'-9"	
16	#5	20'-5"	
16	#8	8'-11"	
16	#5	8'-11"	
8	#8	29'-0"	
8	#5	27'-0"	
186	#4	5'-3"	
203	#5	4'-1"	
76	#8	16'-8"	
48	#8	8'-11"	
30	#8	16'-8"	

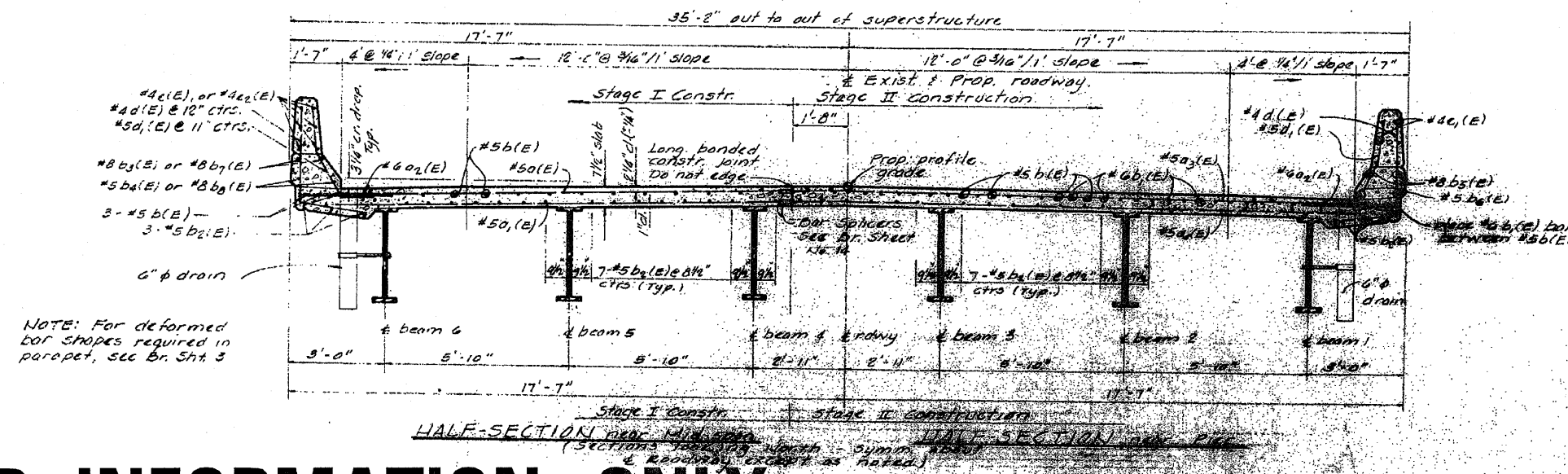

HALF-SECTION near Midspan
 (SECTIONS symm. about $\frac{1}{2}$ of bridge & roadway, except as noted.)
 HALF-SECTION near Pier

SUPERSTRUCTURE - DECK - 138 BR-1

PROJECT
 RTE. FA 634 (IL 82)
 SECTION 138R-1, over North Branch of Edwards River,
 COUNTY HENRY
 STATION 671+37

FOR INFORMATION ONLY

FILE NAME =	USER NAME = linkdj	DESIGNED -	REVISED -	STATE OF ILLINOIS DEPARTMENT OF TRANSPORTATION	Existing Bridge Plans Structure No. 037-0137	F.A. RTE.	SECTION	COUNTY	TOTAL SHEETS	SHEET NO.
0:\BR\Bridge Painting\Contracts\PAINTING\64G8B\PLA\eng.dgn		DRAWN -	REVISED -			var D2 Bridge Painting 2011-2	various	25	10	
PLLOT SCALE = 50.0000' / IN.		CHECKED -	REVISED -			SCALE: _____ SHEET NO. _____ OF _____ SHEETS STA. _____ TO STA. _____		CONTRACT NO. 64G88		
PLLOT DATE = Sat Jan 22 07:11:10 2011		DATE -	REVISED -					ILLINOIS FED. AID PROJECT		

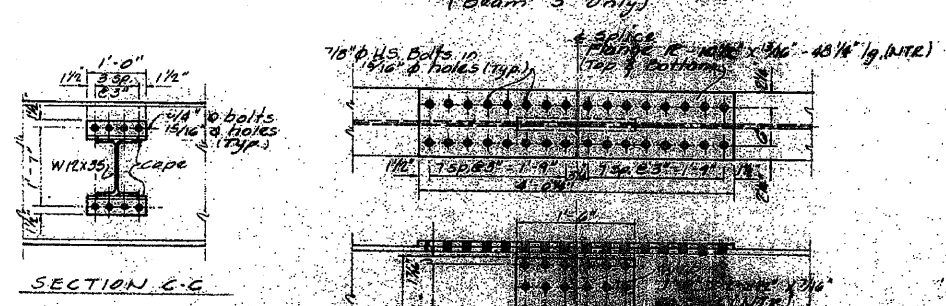
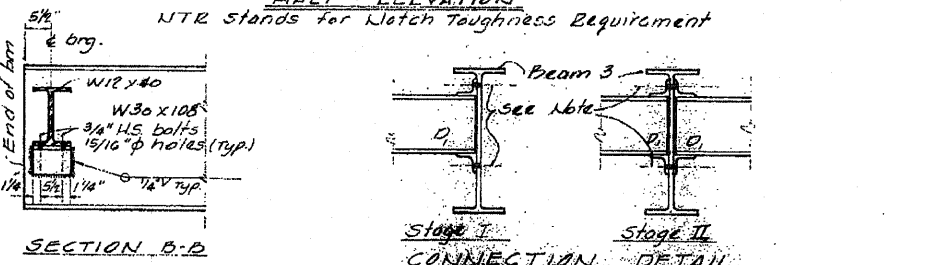
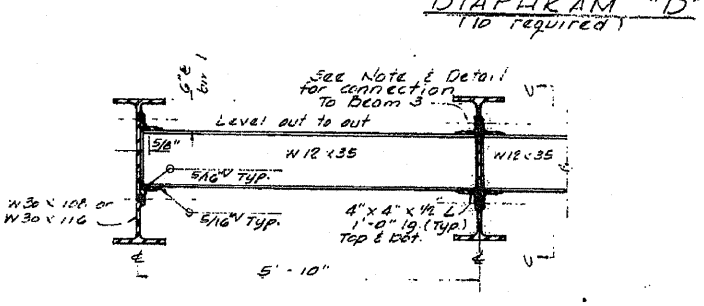
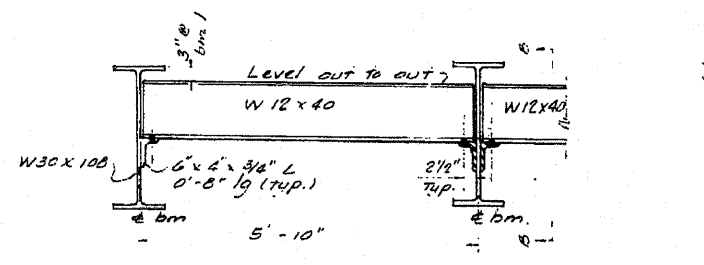
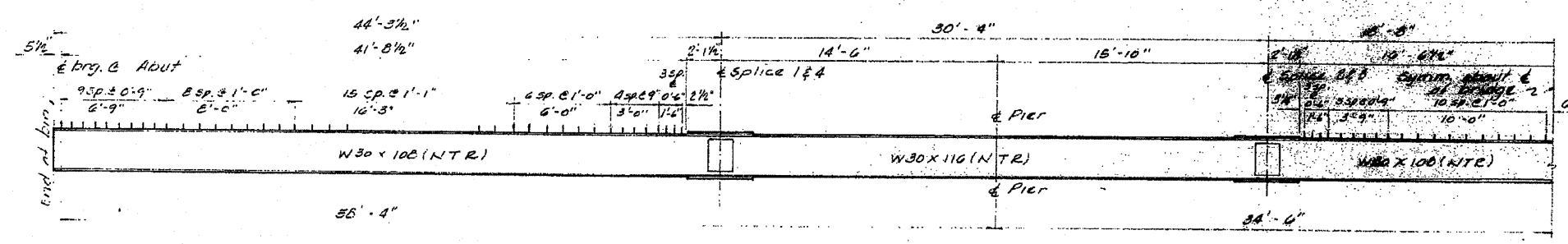
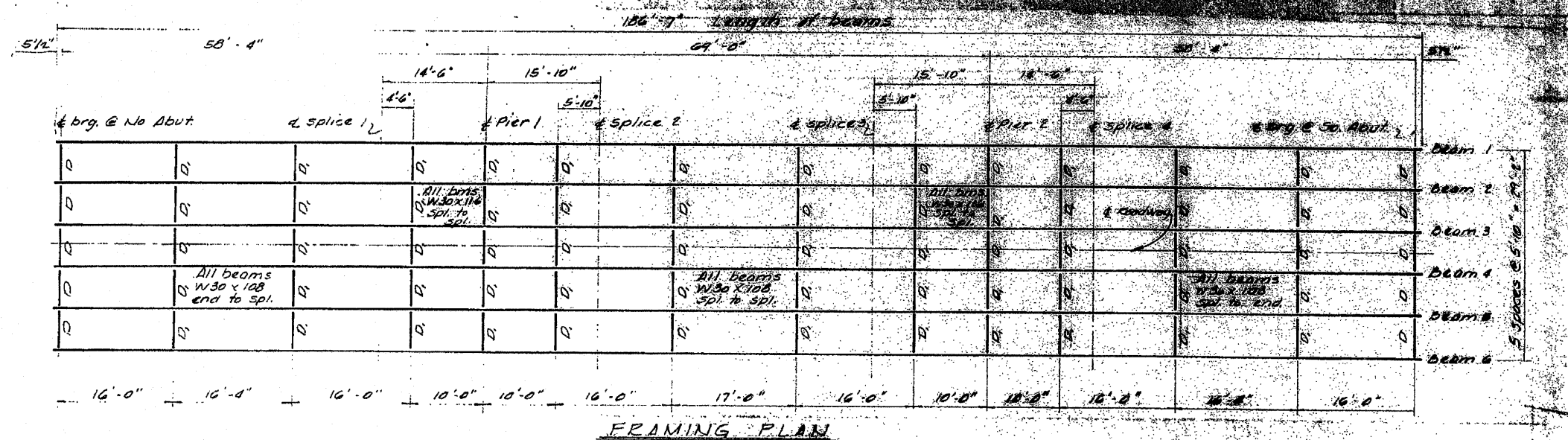

SECTION A-A

3/4" φ granular or solid flux-filled headed studs automatically end welded 2258 required

SHEAR CONK DETAIL

Note: See Br. Sht. No. for determining fillet height "c"

58'-4" 69'-0" 58'-4"

1 Sp. 2 Sp. 3 Sp. 4 Sp.

Base line (Top of beam & brg. abut.)

TOP OF BEAM ELEVATIONS (for fabrication only)									
6' brg. 15' Abut.	1 Sp. 1-Span	2 Sp. 2-Span	3 Sp. 3-Span	4 Sp. 4-Span	5 Sp. 5-Span	6 Sp. 6-Span	7 Sp. 7-Span	8 Sp. 8-Span	9 Sp. 9-Span
BEAMS 1&2	711.91	711.88	711.92	711.83	711.80	711.87	711.77	711.79	711.79
BEAMS 3&4	712.02	711.94	712.02	711.93	711.91	711.97	711.88	711.89	711.89
BEAMS 5&6	712.11	712.03	712.11	712.02	712.00	712.07	711.97	711.99	711.99

FRAMING PLAN

PROJECT:
ROUTE: FA 634 (IL 82)
SECTION: 1368R-1, over North Branch of Edwards River
COUNTY: HENRY
STATION: 671 + 37

FOR INFORMATION ONLY

FOR INFORMATION ONLY

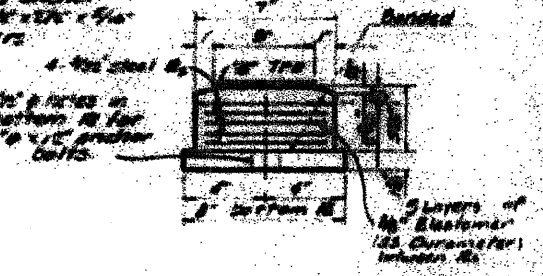
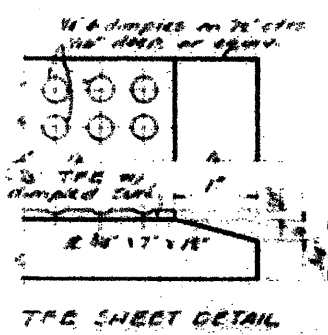
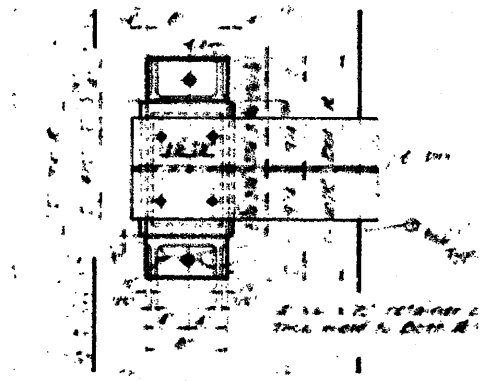
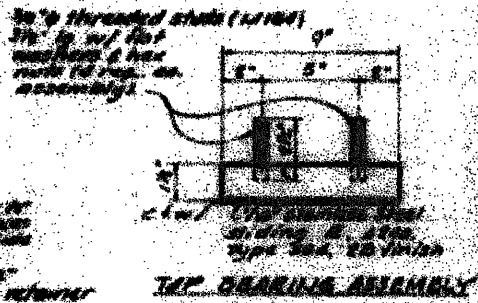
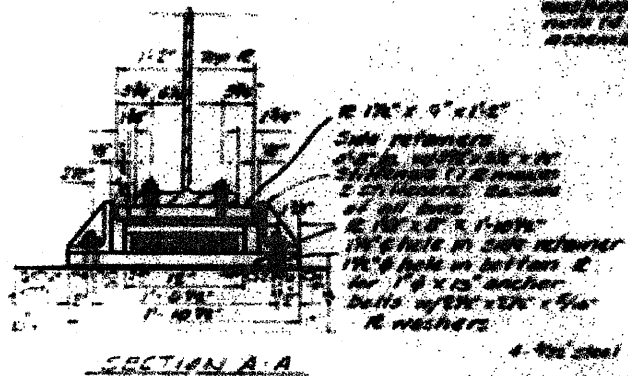
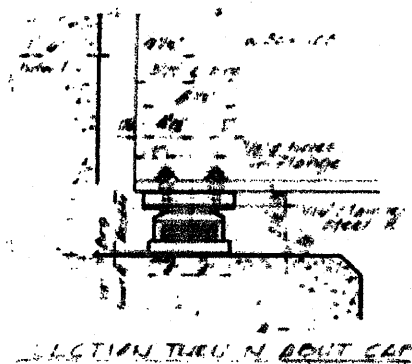

NOTE: THE TPE SHEET SHALL BE BONDED DIRECTLY TO THE TOP STEEL RAIL WITH A TWO COMPONENT, MEDIUM VISCOSITY EPOXY RESIN, conforming to the requirements of the Federal Spec. MSHA-A-136, TYPE I. THE bonding agent shall be applied on the full area of the contact surfaces. Bonding of TPE sheet during vulcanizing process will be permitted provided the process and method of adjusting height is approved by the Engineer.

TYPE II BEARING DETAILS @ NORTH ABUTMENT

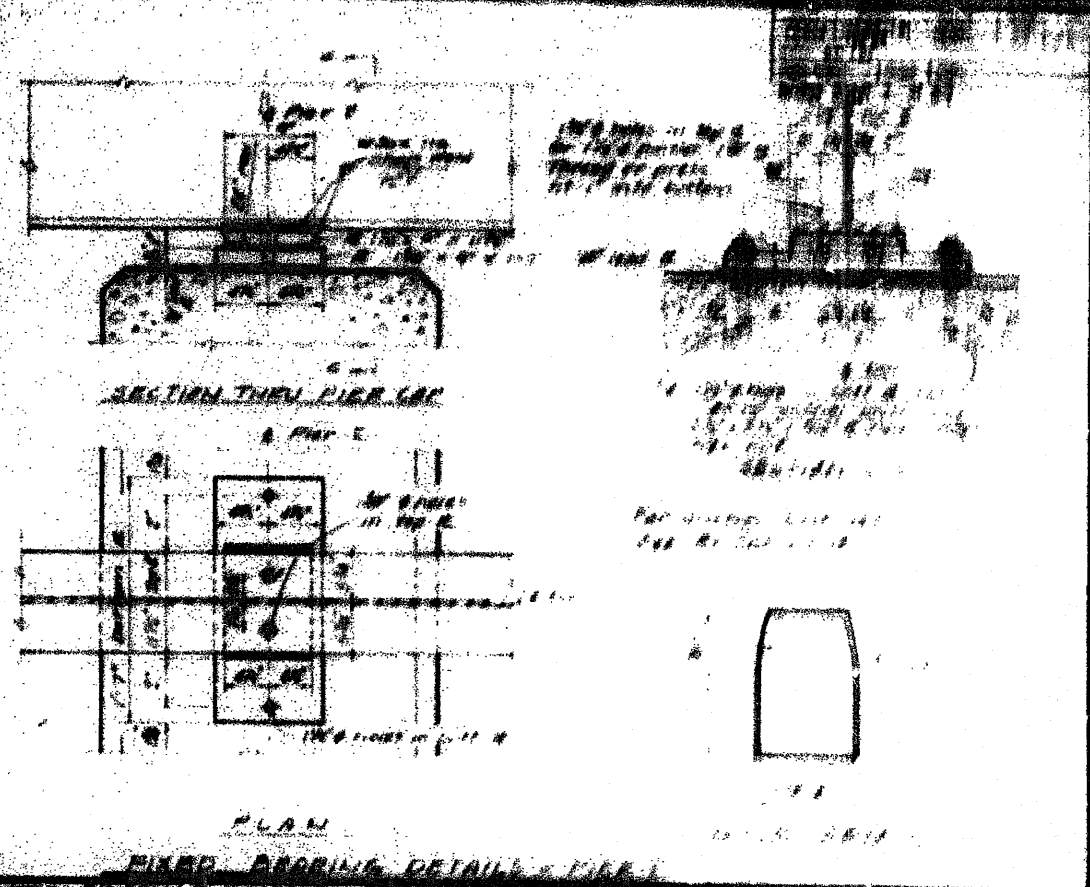

PIERS BEARING DETAILS @ PIER 1

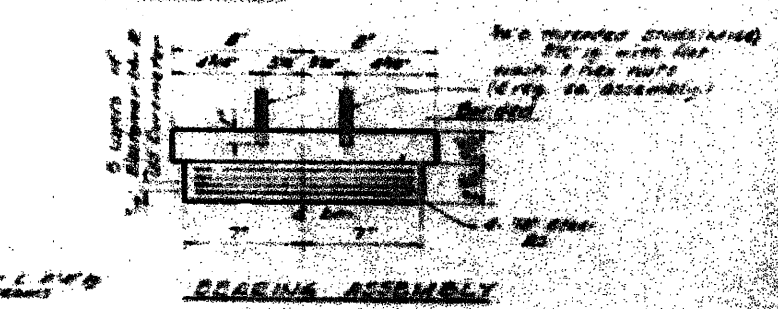
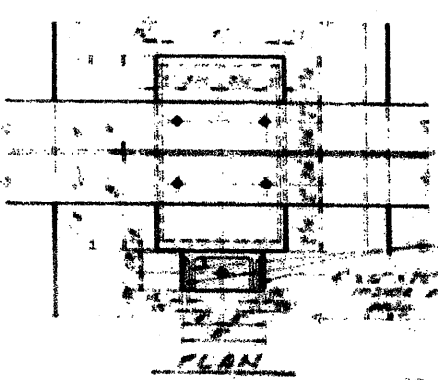
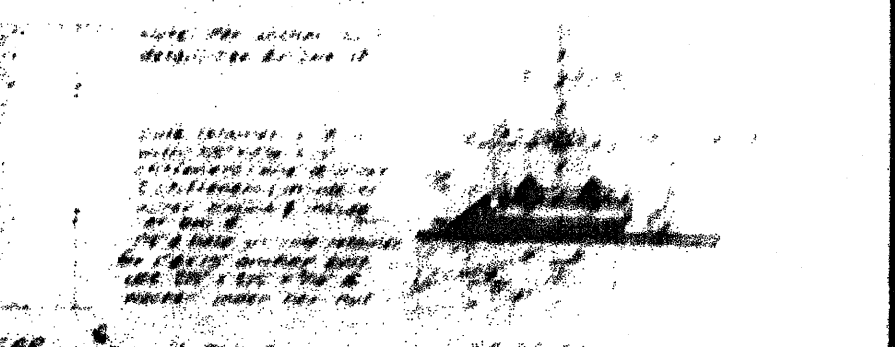
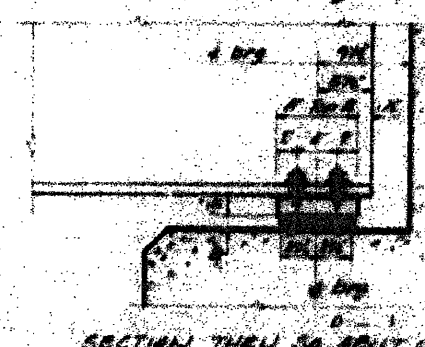
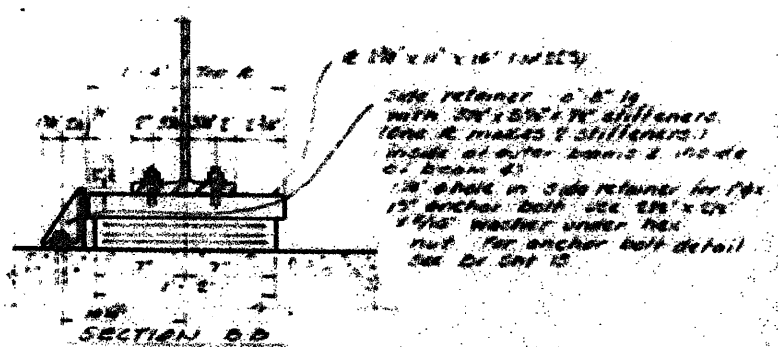
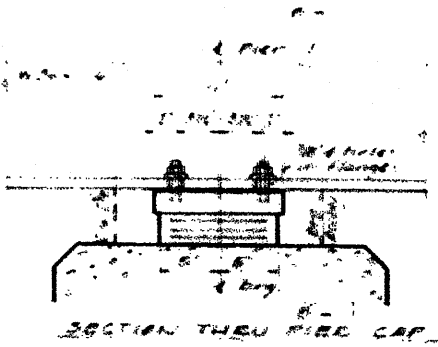

TYPE I BEARING DETAILS @ PIERS

FILE NAME =	USER NAME = linkj	DESIGNED -	REVISION -
G:\BR\Bridg Painting\Contracts\PAINTING\64688\PLANeng.dgn		DRAWN -	REVISION -
		CHECKED -	REVISION -
		DATE -	REVISION -
PLOT SCALE = 50.0000' / IN.			
PLOT DATE = Sat Jan 22 07:10:55 2011			

STATE OF ILLINOIS
DEPARTMENT OF TRANSPORTATION

Existing Bridge Plans
Structure No. 037-0137
SCALE: _____ SHEET NO. _____ OF _____ SHEETS STA. _____ TO STA. _____

F.A. RTE.	SECTION	COUNTY	TOTAL SHEETS	SHEET NO.
var	D2 Bridge Painting 2011-2	various	25	12
			CONTRACT NO. 64G88	
ILLINOIS FED. AID PROJECT				

Route	Section	County	Sheet No.
FA 634	138B	HENRY	25 of 27
Station	930 + 50		
Bridge Sheet 15 of 29 sheets			

0.1% - RR spike in 10' left station 929+50. Elev. 713.03
 Existing Bridge 3 span with 14" deep girders in each span.
 Solid concrete abutments and concrete piers.
 Reinforced concrete slab with wearing surface and
 2" asphalt overlay. SN 027. 2.5% to 3.0% slope.

The information shown for the Temporary Sheet Piling is assumed. It is the contractor's responsibility to provide a design of the Temporary Sheet Piling and associated members, if required, subject to the approval of the Engineer.

GENERAL NOTES:
 SEE PROPOSAL FOR BORING DATA.

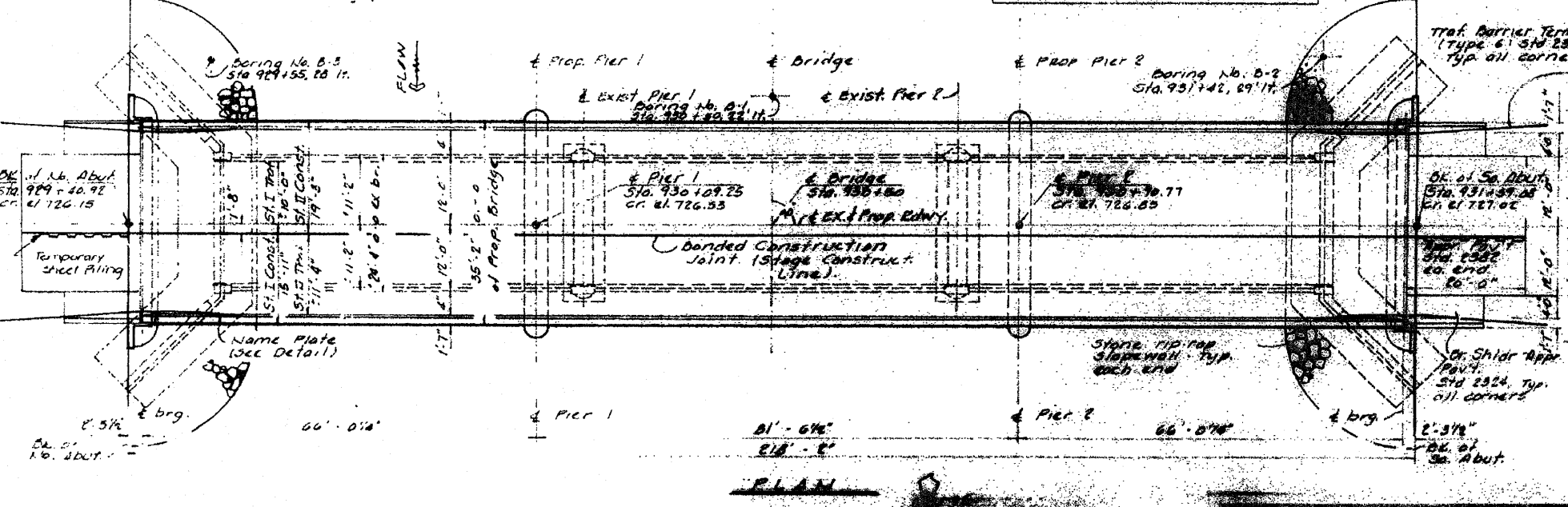
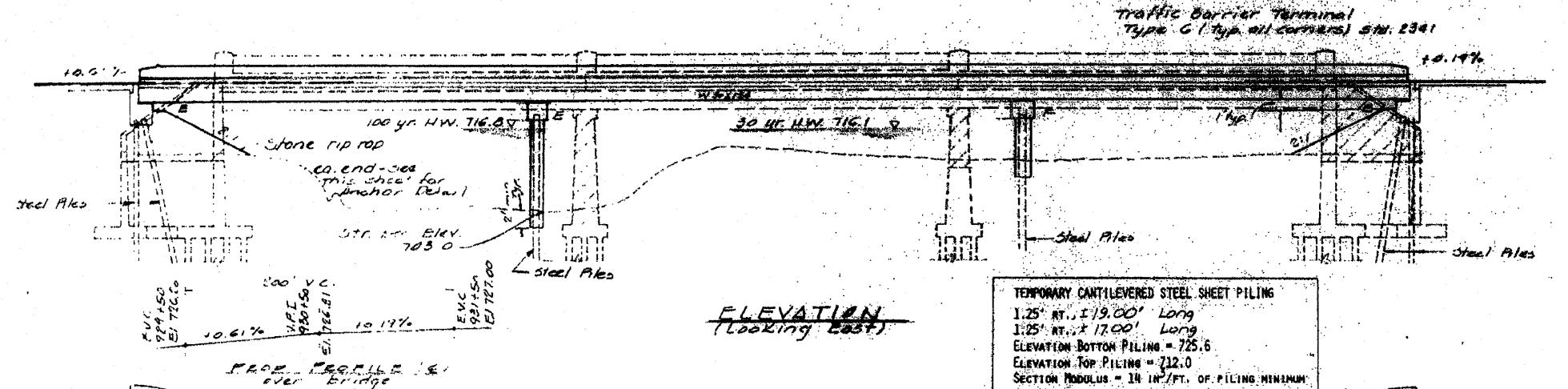

THE CONTRACTOR SHALL DRIVE ONE (1) STEEL PILE HP10x42 IN A PERMANENT LOCATION AT PIER 1 AND ONE (1) STEEL PILE HP10x42 IN A PERMANENT LOCATION AT PIER 2 AS DIRECTED BY THE ENGINEER BEFORE ORDERING THE REMOVAL OF THE PILE.

LAUNCH OF THE STONE RIPRAP SLOPEWALL MAY BE VARIED IN THE FIELD TO SUIT THE EXISTING GROUND CONDITIONS AS DIRECTED BY THE ENGINEER. REINFORCEMENT BARS SHALL CONFORM TO THE REQUIREMENTS OF AASHTO M-31, M-42 OR M-53, GRADE 60.

BEARING SURFACES SHALL BE CONSTRUCTED OR ADJUSTED TO THE DESIGNATED ELEVATIONS WITHIN A TOLERANCE OF 1/8" INCH. ADJUSTMENTS SHALL BE MADE EITHER BY GRINDING THE SURFACE OR SHIMMING THE BEARING. THE 1/8" INCH ADJUSTING SHIMS, OF THE DIMENSIONS OF THE BOTTOM BEARING PLATE, SHALL BE PROVIDED FOR EACH BEARING IN ADDITION TO ALL OTHER PLATES OR SHIMS. FOR THE TYPE I ELASTOMERIC BEARINGS, SHIMS HAVING THE DIMENSIONS OF THE TOP PLATE SHALL BE PROVIDED AND PLACED AS DETAILED. FASTENERS SHALL BE HIGH-STRENGTH BOLTS. BOLTS SHALL BE 3/4" DIA., OPEN HOLES 13/16" DIA., UNLESS OTHERWISE NOTED ON THE PLANS AND SHALL CONFORM TO THE REQUIREMENTS OF AASHTO M-164.

THE EPOXY-BELT AND 100% VINYL PAINT SYSTEM SHALL BE USED FOR THE SHIP AND THE BEARING SURFACES. STRUCTURAL STEEL SHALL BE OTHERWISE SPECIFIED.

FIELD WELDING OF CONSTRUCTION ACCESSORIES WILL NOT BE PERMITTED TO THE UPPER FLANGE OF THE BEAM NOR TO THE TOP FLANGE OF THE BEAM FOR A DISTANCE EQUAL TO 1/4 THE SPAN LENGTH EACH WAY FROM THE PIER SUPPORTS. FIELD WELDING IN OTHER AREAS WILL BE PERMITTED ONLY WITH THE APPROVAL OF THE ENGINEER.

BOLTS SHALL BE SET BEFORE BOLTING DIAPHRAGMS OVER SUPPORTS. THE STRUCTURAL STEEL BEARING PLATES OF THE ELASTOMERIC BEARING ASSEMBLIES SHALL CONFORM TO THE REQUIREMENTS OF AASHTO M-223, GRADE 50. MAIN LOAD CARRYING MEMBER COMPONENTS SUBJECT TO TENSILE STRESS SHALL CONFORM TO THE STRUCTURAL REQUIREMENTS FOR NOTCH TOUGHNESS AND 2. THESE COMPONENTS ARE THE WIDE FLANGE BEAMS AND ALL SPLICE PLATE MATERIAL OF THE BEAMS.

CALCULATED HEIGHT OF THE STRUCTURAL STEEL:
 M 103 10779 lbs
 M 243 6050 17495 lbs



WATERWAY INFORMATION										
Drainage Area 52.5 Sq. Mi. cw grade elev. 723.3 e Station 923+29										
Flood	freq. yr.	Opening - S.C.			Not. H.W.E.	Head H.		Headwater elev.		
		Exist.	Prop.	101.0		Exist.	Prop.	Exist.	Prop.	
Design	Main Channel	50	4232	993	101.0	716	0.70	0.59	716.00	716.69
	Overflow	50	550	55	86					
Base	Main Channel	100	4422	1046	1073	716.0	0.95	0.76	717.73	717.50
	Overflow	100	5431	1119	1154					
Max. or Overflow	Main Channel	500	5728	1182	1277					
	Overflow	500	7073	300						
Total	Main Channel		345	64	717.5		1.02			718.52
	Overflow		1529	1829						

STATION 930+50
 BUILT 1988 BY
 STATE OF ILLINOIS
 FA 634 SEC 138B
 FA PROJECT (SHEET 1)
 LOADS 40-50
 STRUCTURE NO. 037-0138

APPROVED

TOTAL BILL OF MATERIAL - 1988, BRIDGE ONLY			
ITEM	UNIT	QUANTITY	EST. COST
CONCRETE	CY	100	10000
STEEL	LB	10000	100000
WOOD	CU YD	10	1000
ASPHALT	SQ YD	1000	10000
GRAVEL	CY	100	1000
STONE RIPRAP	CY	100	1000
TRAF. BARRIER	LN	100	1000
PAINT	SQ YD	1000	10000
LABOR	HR	10000	100000
EQUIPMENT	HR	1000	10000
TOTAL			200000

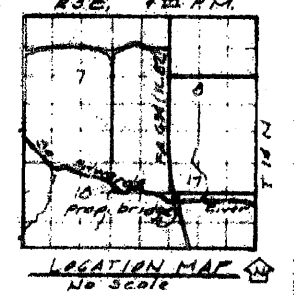

GENERAL PLAN & ELEVATION

PROJECT
 RTE. FA 634 (IL 82)
 SECTION 138B over South Branch
 Edwards River

COUNTY HENRY
 STATION 930 + 50

FOR INFORMATION ONLY

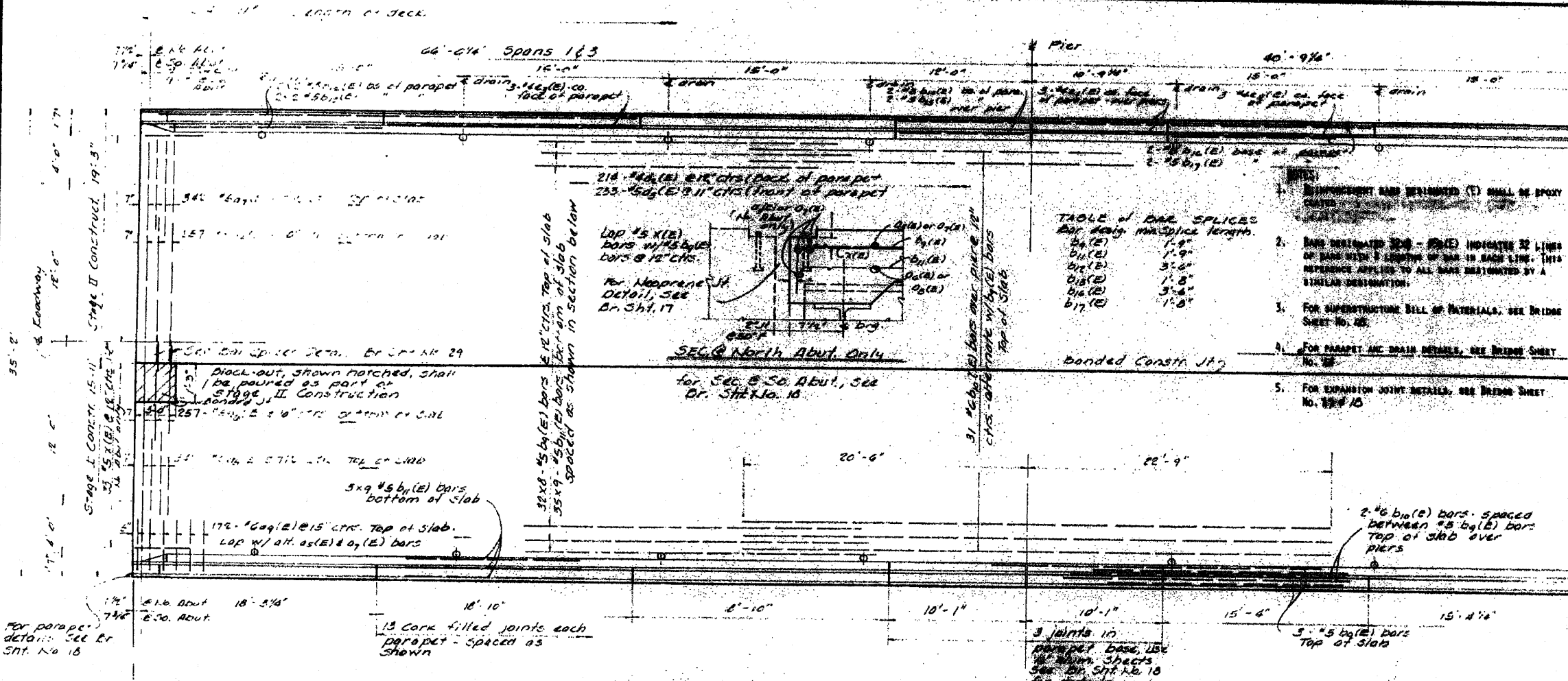
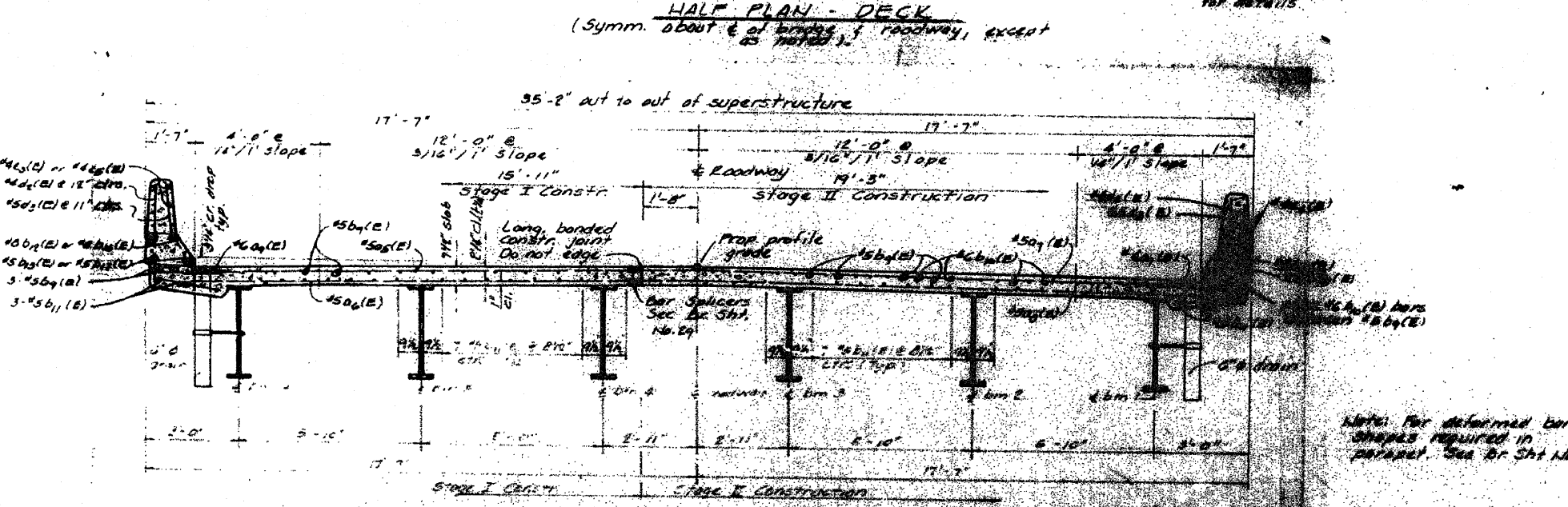

TABLE of BAR SPLICES

Bar Design	Splice Length
#4(E)	1'-9"
#5(E)	1'-9"
#6(E)	3'-0"
#6(E)	1'-8"
#6(E)	3'-0"
#6(E)	1'-8"

- REINFORCEMENT BARS DESTINATED (E) SHALL BE EPOXY COATED.
- BARS DESTINATED (E) - (E) INDICATES 32 LINES OF BARS WITH A LENGTH OF BAR IN EACH LINE. THIS REQUIREMENT APPLIES TO ALL BARS DESTINATED BY A SIMILAR DESIGNATION.
- FOR SUPERSTRUCTURE BILL OF MATERIALS, SEE BRIDGE SHEET NO. 48.
- FOR PARAPET AND DRAIN DETAILS, SEE BRIDGE SHEET NO. 48.
- FOR EXPANSION JOINT DETAILS, SEE BRIDGE SHEET NO. 48 & 10.



BAR LIST - SUPERSTRUCTURE

Bar	No.	Size	Length	Shape
#4(E)	345	#4	14'	—
#4(E)	257	#4	14'	—
#4(E)	368	#4	7'-1"	—
#4(E)	257	#4	14'	—
#4(E)	344	#4	14'	—
#4(E)	304	#4	14'	—
#4(E)	71	#4	14'	—
#4(E)	369	#4	27'-4"	—
#4(E)	15	#4	14'	—
#4(E)	4	#4	27'-4"	—
#4(E)	14	#4	14'	—
#4(E)	8	#4	14'	—
#4(E)	8	#4	14'	—
#4(E)	214	#4	14'	—
#4(E)	233	#4	14'	—
#4(E)	72	#4	14'	—
#4(E)	47	#4	14'	—
#4(E)	21	#4	14'	—
#4(E)	37	#4	14'	—

SUPERSTRUCTURE DECK 138 BR

PROJECT
 RTE. FA 634 (IL 62)
 SECTION 138 BR over South Branch of
 Edwards River

COUNTY HENRY
 STATION 930+50

FOR INFORMATION ONLY

Route	Station	County	Sheet No.
PA 634	110+00	HENRY	29
Sheet 29 of 29			

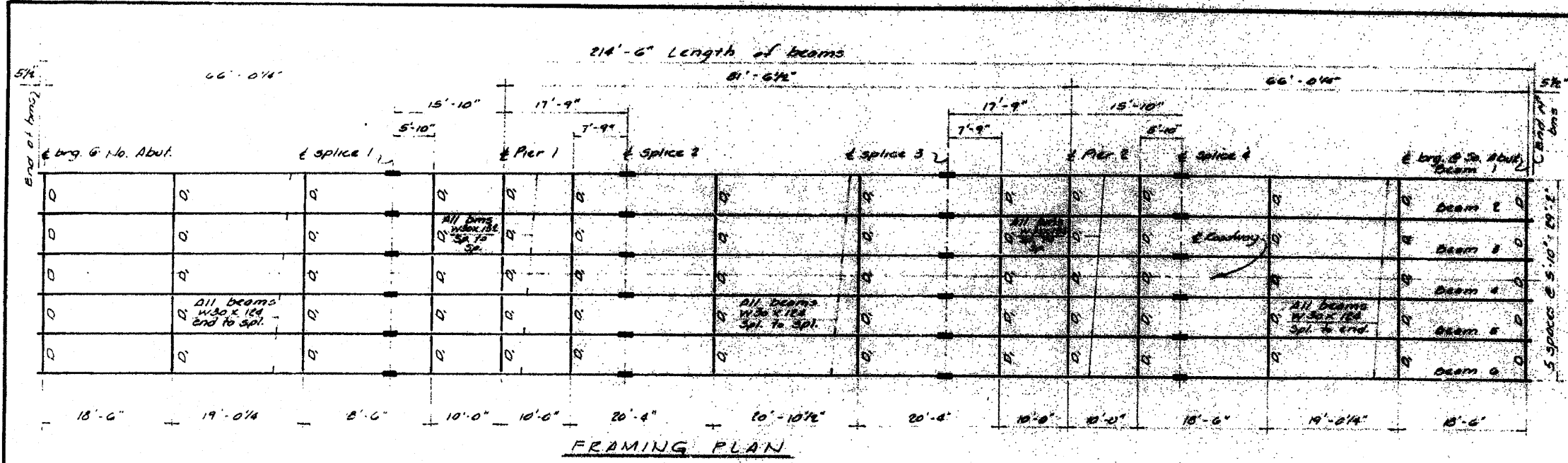

SECTION A-A

SYD SHEAR CONNECTOR

PLAN

SECTION A-A

Note: See Dr. Sht. No. 81 for determining fillet height "L".

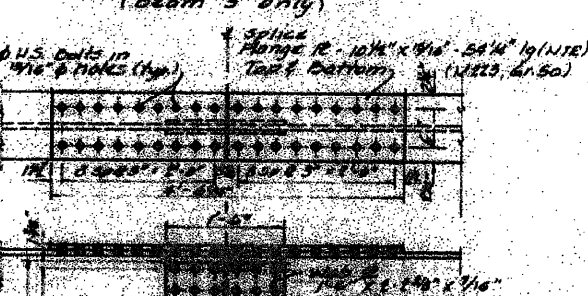
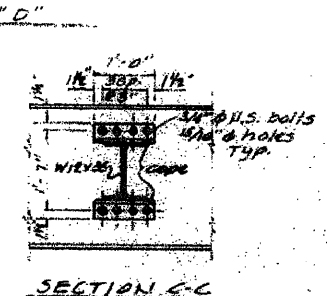
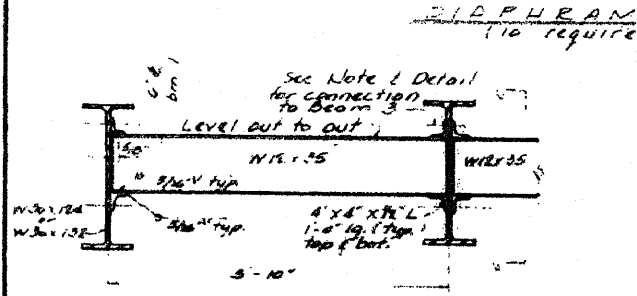
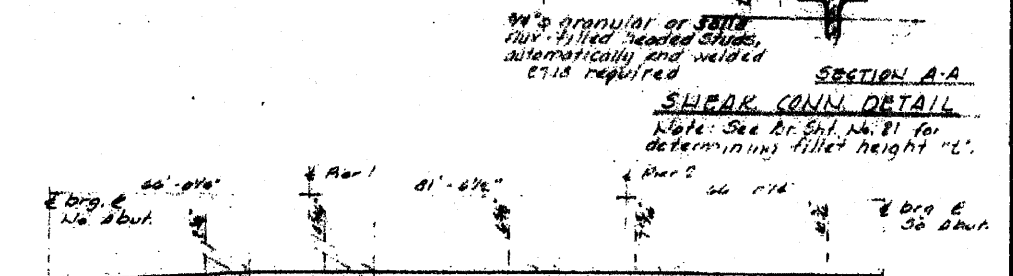
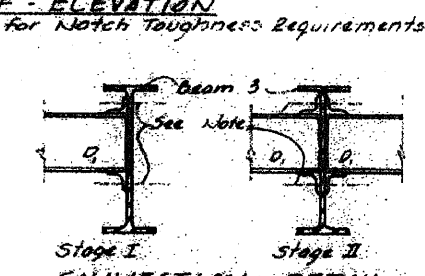
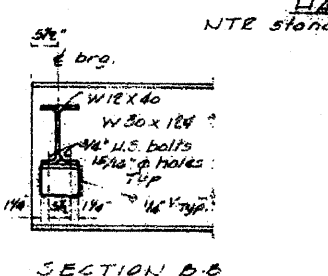
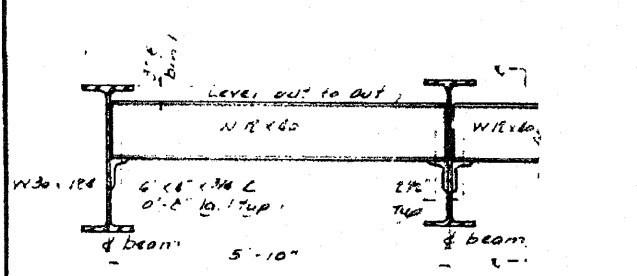
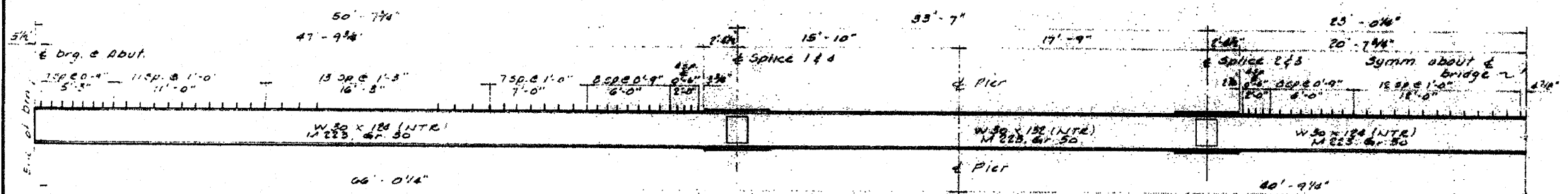

TOP OF BEAM ELEVATIONS (for fabrication only)

Beam	Splice 1	Splice 2	Splice 3	Splice 4	Splice 5	Splice 6	Splice 7	Splice 8
BEAMS 110	785.25	785.45	785.66	785.62	785.80	785.94	785.91	786.10
BEAMS 115	785.36	785.56	785.72	785.72	785.91	786.05	786.01	786.21
BEAMS 118	785.45	785.65	785.81	785.81	786.00	786.14	786.10	786.30

Note: BEAMS are NCSB 61-50
Diaphragms are NCSB

FOR INFORMATION ONLY

FRAMING PLAN

PROJECT
RTE PA 634 (IL 82)
SECTION 130 BR over South Branch of
Edward River
COUNTY HENRY

FOR INFORMATION ONLY

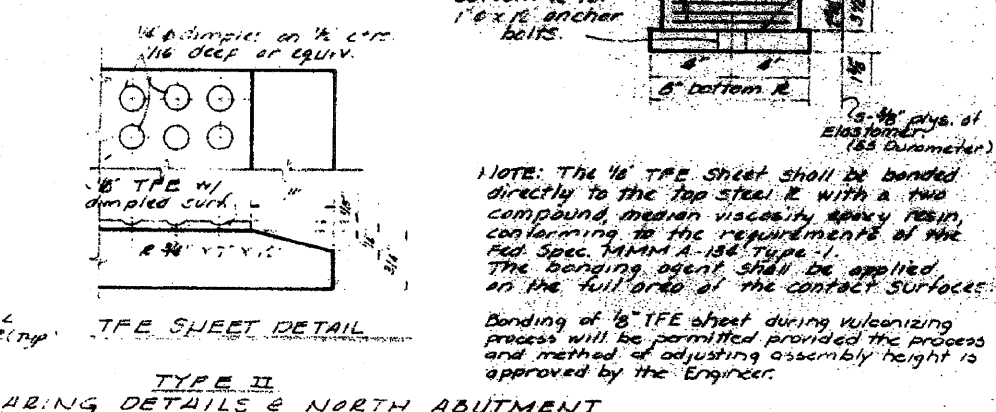
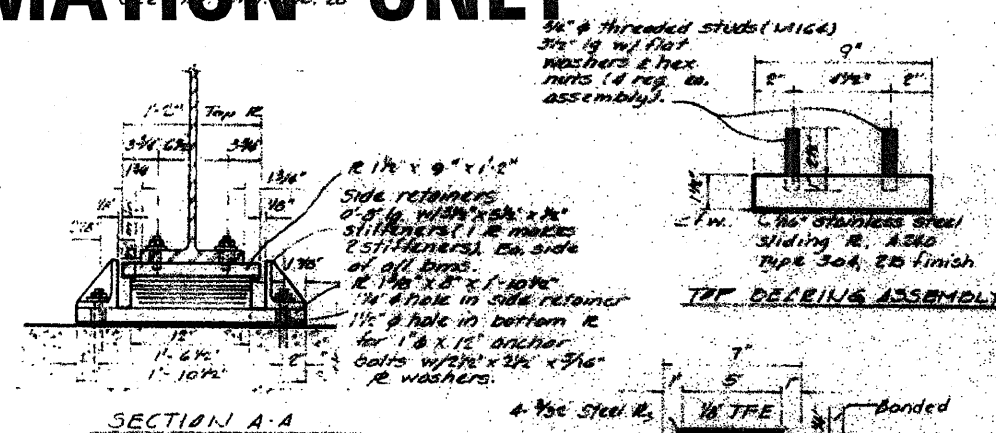
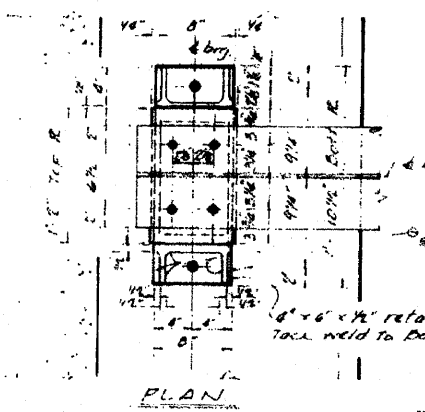
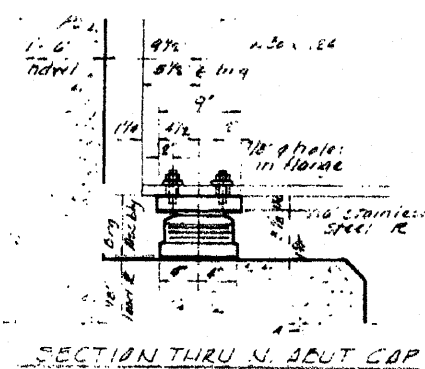

TYPE II BEARING DETAILS & NORTH ABUTMENT

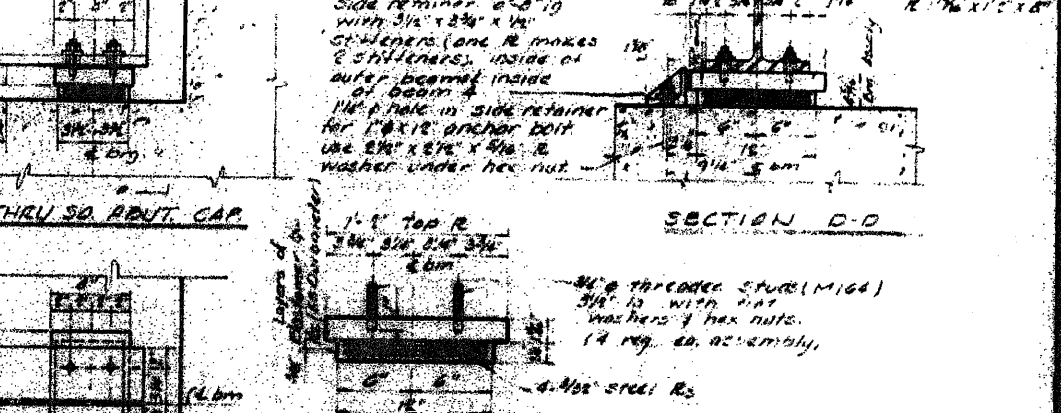
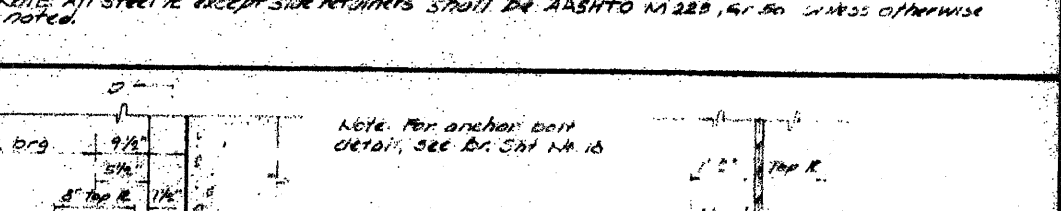
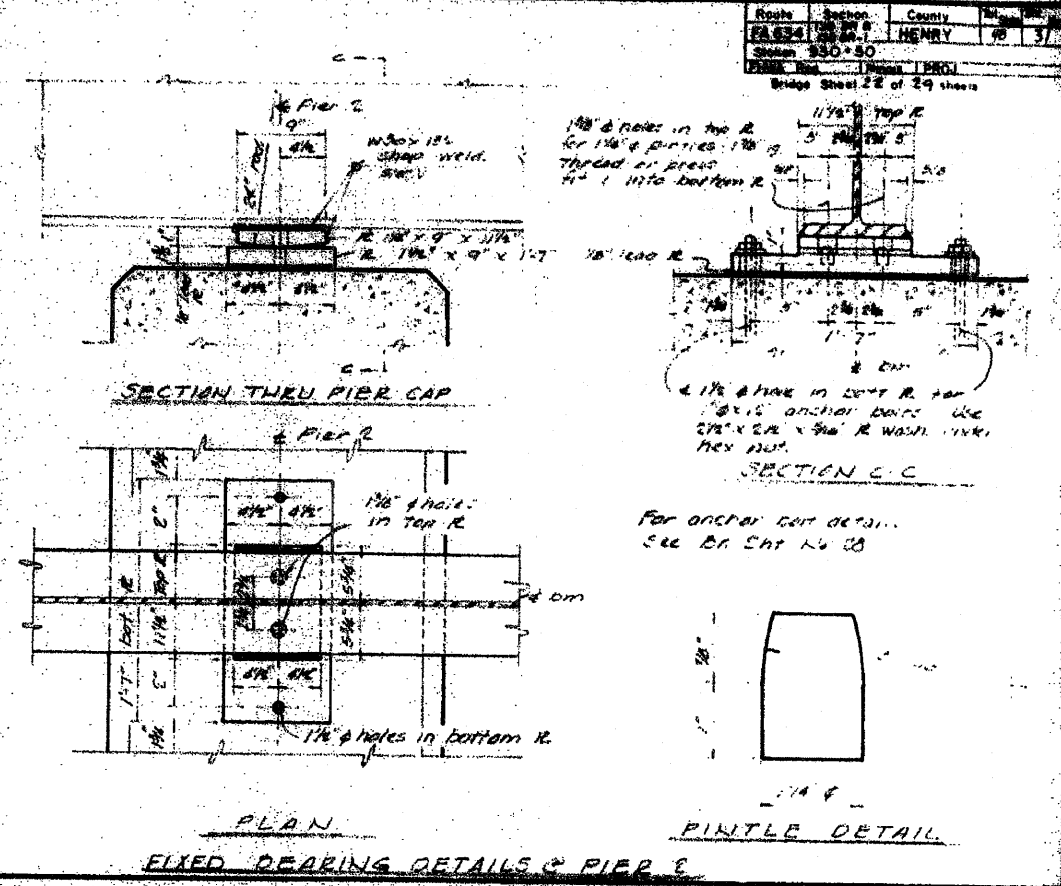

FIXED BEARING DETAILS & PIER E

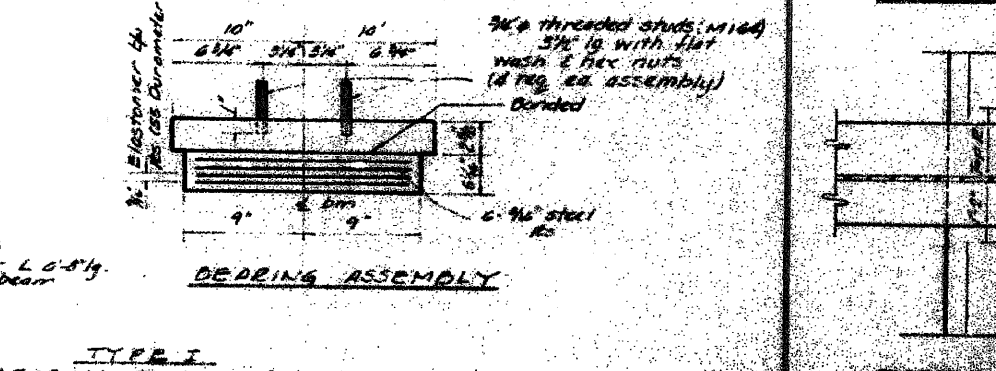
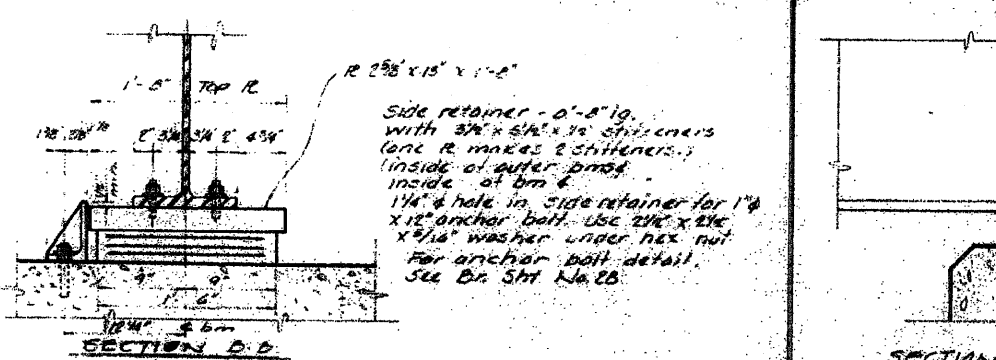
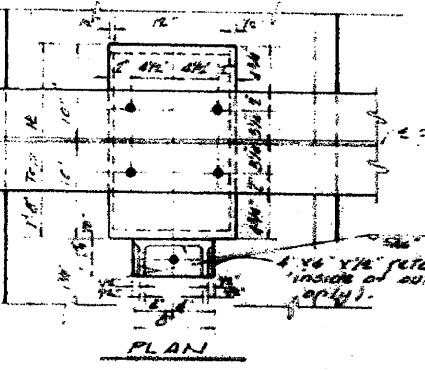
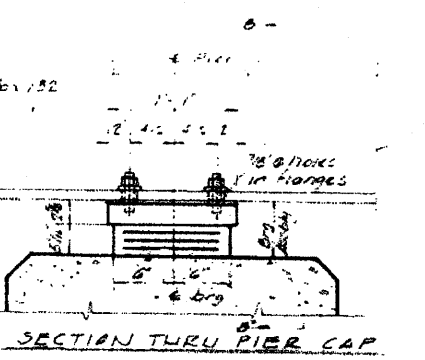

TYPE I BEARING DETAILS & PIER I

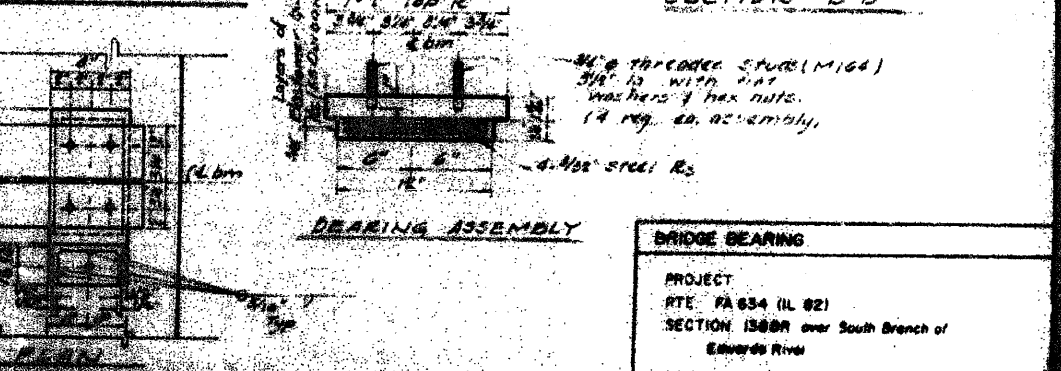
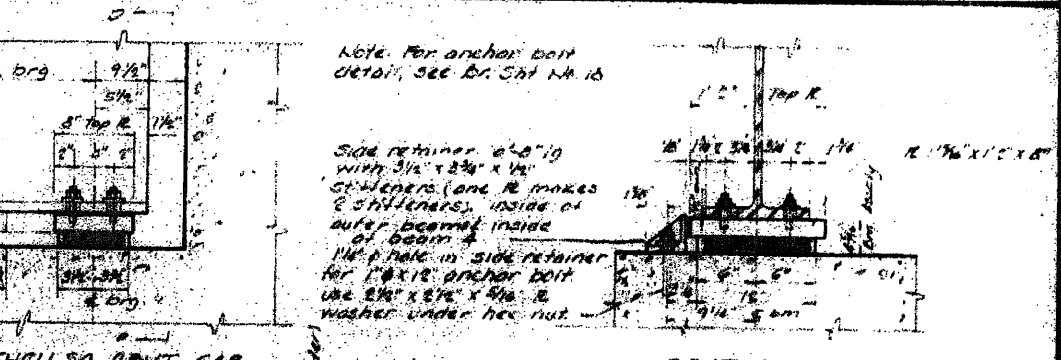

TYPE I BEARING DETAIL & S.D. ABUTMENT

Route	Section	County	Sheet No.
PA 634	D2	HENRY	25
Sheet 530-50			
Bridge Sheet 22 of 29 sheets			

BRIDGE BEARING				
PROJECT				
RTE. PA 634 (IL 82)				
SECTION 1368R over South Branch of				
Edwards River				
COUNTY HENRY				

F.A. RTE.	SECTION	COUNTY	TOTAL SHEETS	SHEET NO.
var D2	Bridge Painting 2011-2	various	25	16
			CONTRACT NO. 64C88	
ILLINOIS FED. AID PROJECT				

STATE OF ILLINOIS
DEPARTMENT OF TRANSPORTATION

Existing Bridge Plans
Structure No. 037-0138

FILE NAME =	USER NAME = linkdj	DESIGNED -	REVISED -
D:\NBR\Bridge Painting\Contracts\PAINTING\64C88\PLA\eng.dgn		DRAWN -	REVISED -
	PLOT SCALE = 50.0000 / IN.	CHECKED -	REVISED -
	PLOT DATE = Sat Jan 22 07:10:21 2011	DATE -	REVISED -

SCALE: SHEET NO. OF SHEETS STA. TO STA.

STATE OF ILLINOIS
DEPARTMENT OF TRANSPORTATION

DATE	DESIGNED	CHECKED	DRAWN	SHEET NO.
1/17/12	Dau Krull	J.K. M.J.R. R.E.	S.G. FERGUSON	7
PROJECT NO. 089-0042				SHEETS 33

Bench Mark: #18 R.R. Spike in 9' Tree on South Bank of River,
22' East of Large Maple (cluster of 5) 1000' West S.E. Corner
Sec. 27 Elev. 750.223 (Sta. 941+94.00, B.L.)
No Existing Structure

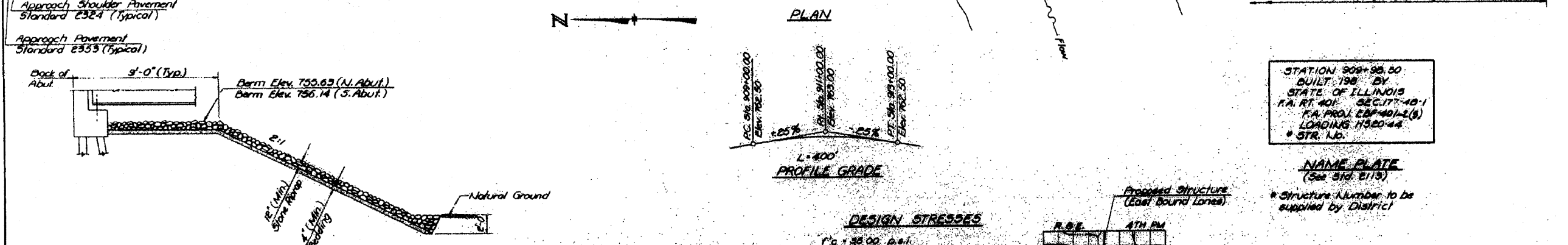
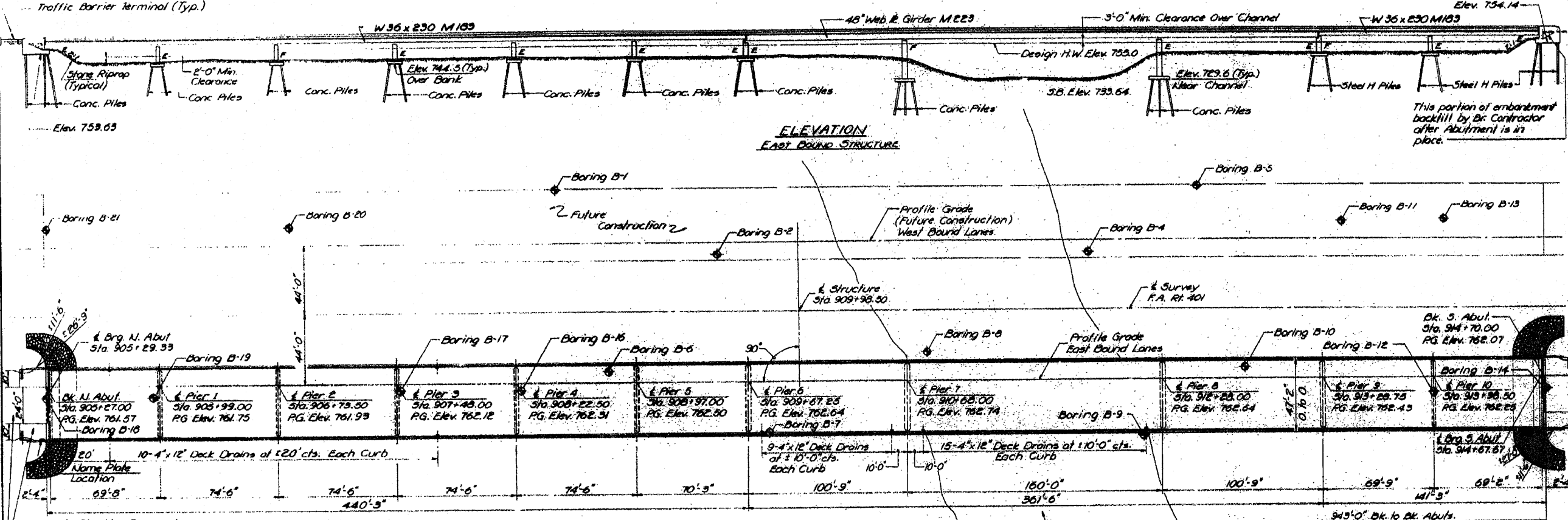

DESIGNED	DAU KRULL
CHECKED	J.K. M.J.R. R.E.
DRAWN	S.G. FERGUSON
CHECKED	J.K. M.J.R. R.E.

DATE	6/1/12
APPROVED	[Signature]

WATERWAY INFORMATION

Drainage Area	1590 Sq. Miles
Design Discharge (50 yr.)	80,520 cfs
Exist. Opening (Below 50 yr. H.W.E.)	None
Prop. Opening (Below 50 yr. H.W.E.)	6500 Sq. Ft.
Prop. Opening (Below 100 yr. H.W.E.)	6500 Sq. Ft.
Created Head for Design Flood	0.02 ft.
100-Year Discharge	25,000 cfs
Created Head for 100-Year Flood	0.30 ft.

DESIGN STRESSES

$f_c = 4000$ p.s.i.
 $f_y = 50,000$ p.s.i. (Struct. Spans 7 to 9)
 $f_y = 35,000$ p.s.i. (Struct. All other Spans)
 $f_y = 60,000$ p.s.i. (Reinforcement All Spans)

Epoxy coated rebar shall be used in the top layer of the slab.
 New cast-in-place concrete shall be used for future wearing surface.
 Design Specifications: IRTT Appendix 10.1 and 10.2 and 10.3
 LOADINGS: HS20-44

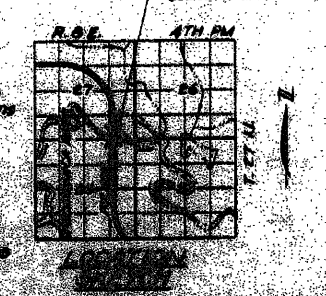

STATION 909+92.50
BUILT 198 BY
STATE OF ILLINOIS
F.A. RT. 401 SEC. 17-18-1
F.A. PROJ. 089-0042-1(S)
LOADING: HS20-44
STR. No.

NAME PLATE
(See 31d. 2113)
* Structure Number to be supplied by District

GENERAL PLAN & ELEVATION
F.A. ROUTE 401
SECTION 17-18-1
STEPHENSON COUNTY
STATION 909+92.50

FOR INFORMATION ONLY

FILE NAME = 0:\BR\Bridge Painting\Contr\acts\PAINTING\64688\PLA\eng.dgn	USER NAME = linkdj	DESIGNED -	REVISD -	STATE OF ILLINOIS DEPARTMENT OF TRANSPORTATION	Existing Bridge Plans Structure No. 089-0042	F.A. RTE. = var	SECTION = D2 Bridge Painting 2011-2	COUNTY = various	TOTAL SHEETS = 25	SHEET NO. = 17
PLOT SCALE = 50.0000' / IN.	PLOT DATE = Sat Jan 22 07:18:12 2011	DRAWN -	REVISD -	SCALE: _____	SHEET NO. _____ OF _____ SHEETS	CONTRACT NO. 64688		ILLINOIS FED. AID PROJECT		

STATE OF ILLINOIS
DEPARTMENT OF TRANSPORTATION

DATE	NO.	BY	REVISION	SHEET NO. 12
11-11-11	089-0042	STEPHENSON	48	11
33 SHEETS				

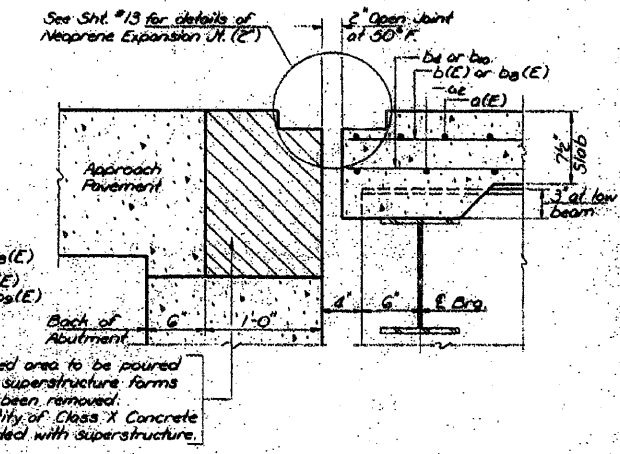
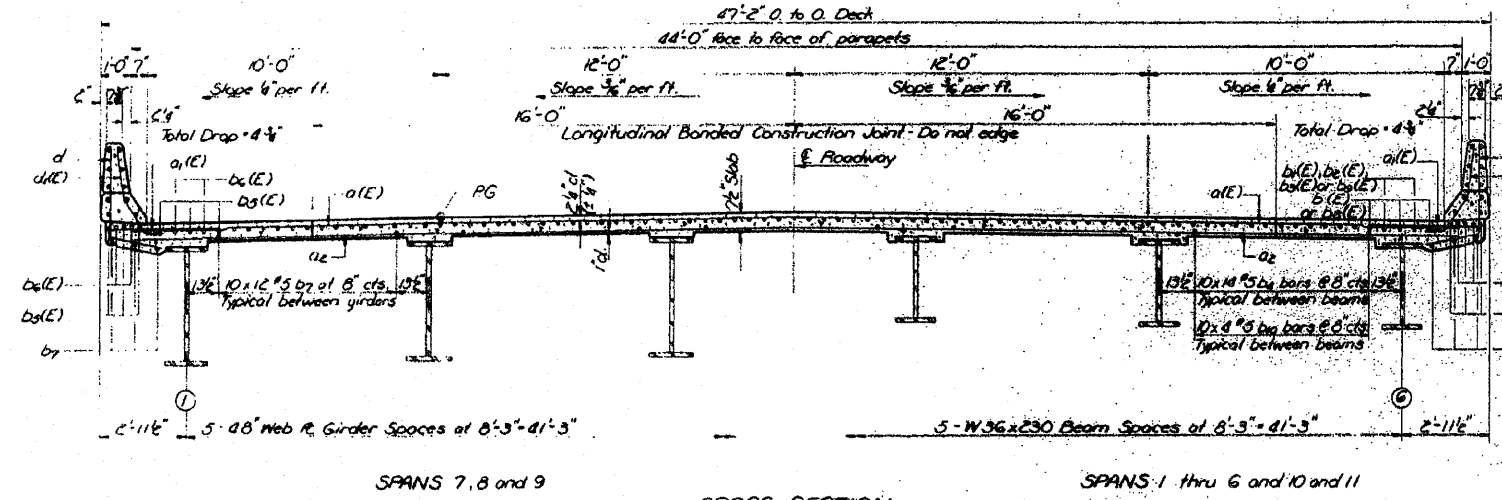

BILL OF MATERIAL

Bar	No.	Size	Length	Shape
a(E)	2305	#5	43'-0"	
a(E)	2306	#6	4'-0"	
a2	1611	#5	45'-0"	
b(E)	700	#5	32'-10"	
b(E)	98	#6	26'-2"	
b(E)	98	#6	23'-5"	
b(E)	47	#6	23'-6"	
b2	784	#5	32'-10"	
b(E)	600	#5	37'-3"	
b(E)	188	#6	42'-6"	
b7	672	#5	37'-8"	
b(E)	200	#5	36'-7"	
b(E)	47	#6	26'-2"	
b2	224	#5	36'-7"	
b7	32	#6	31'-6"	
b2	28	#6	10'-3"	
b2	32	#6	29'-7"	
b2	16	#6	10'-6"	
b2	8	#6	8'-9"	
b2	44	#6	26'-4"	
b2	16	#6	22'-8"	
b(E)	16	#5	30'-6"	
b(E)	12	#5	10'-3"	
b(E)	16	#5	28'-1"	
b(E)	8	#5	10'-6"	
b(E)	8	#5	8'-9"	
b(E)	22	#5	27'-7"	
b(E)	8	#5	22'-8"	
b2	16	#5	30'-6"	
b2	12	#5	10'-3"	
b2	16	#5	28'-1"	
b2	8	#5	10'-6"	
b2	8	#5	8'-9"	
b2	22	#5	27'-7"	
b2	8	#5	22'-8"	
d	1802	#4	14'-11"	
d(E)	2038	#5	3'-11"	
d(E)	16	#5	4'-0"	
e	72	#4	8'-7"	
e	72	#4	10'-3"	
e2	72	#4	17'-8"	
e2	48	#4	10'-6"	
e2	72	#4	18'-0"	
e2	48	#4	8'-9"	
e2	48	#4	10'-3"	
e2	48	#4	10'-6"	
e2	72	#4	18'-0"	
e2	72	#4	18'-0"	

Class 1 Concrete (C-1) 2500
Reinforcement Bars (Round) #4-#10
Reinforcement Bars (Square) #4-#10
(Epoxy Coated) Round #4-#10

Reinforcement bars designated (E) shall be epoxy coated. See Special Provisions.

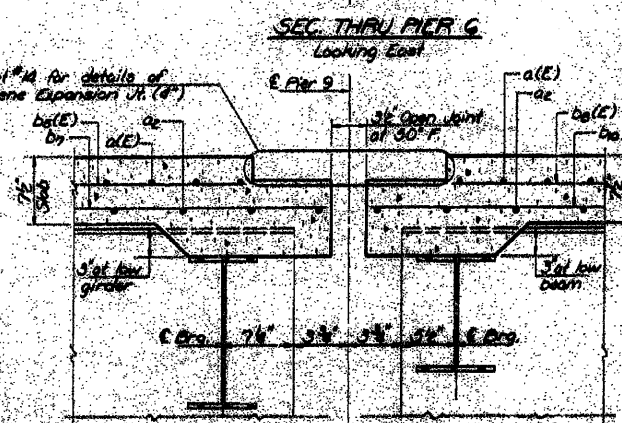
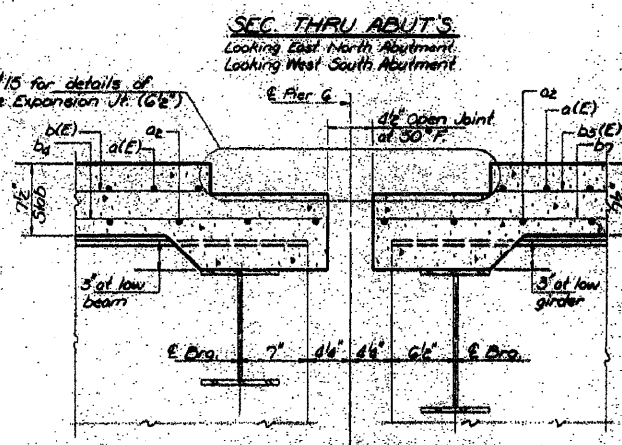
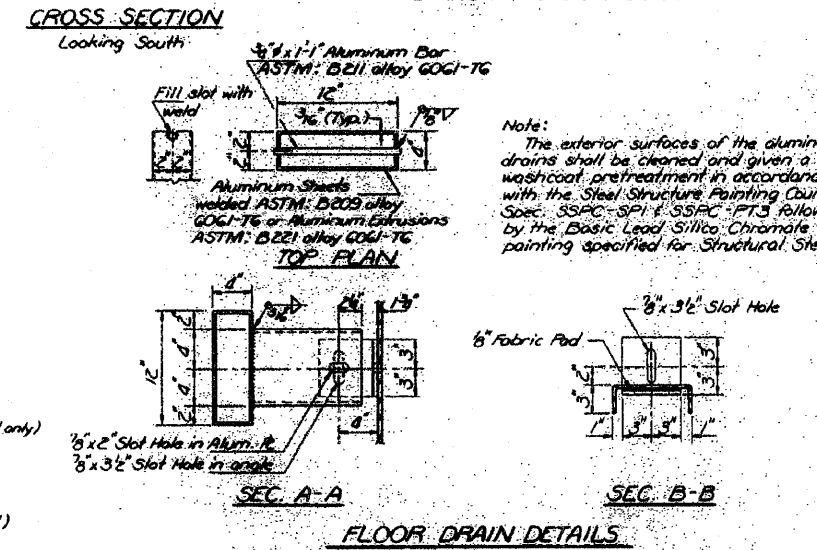
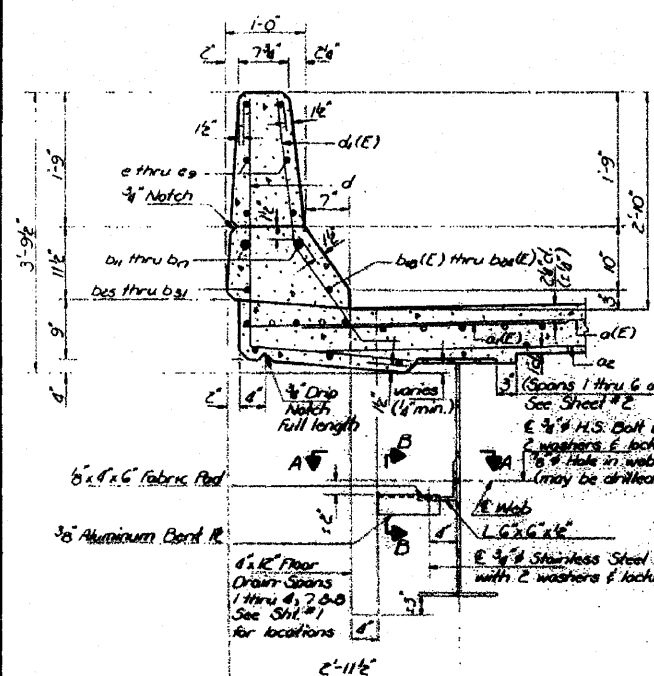

DESIGNED: DAN KRULL
CHECKED: Jim K...
DRAWN: by Sub...
CHECKED: J K

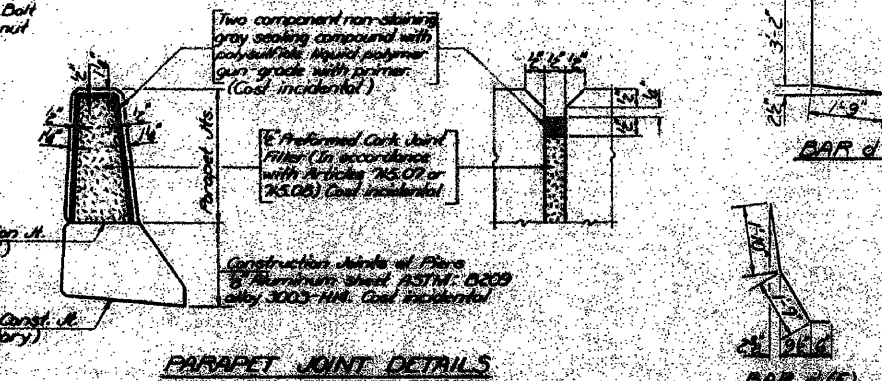

FOR INFORMATION ONLY

STATE OF ILLINOIS
DEPARTMENT OF TRANSPORTATION

DATE	DESIGNER	CHECKER	SCALE	SHEET NO.
11-17-11	Stephenson	41	22	25 SHEETS

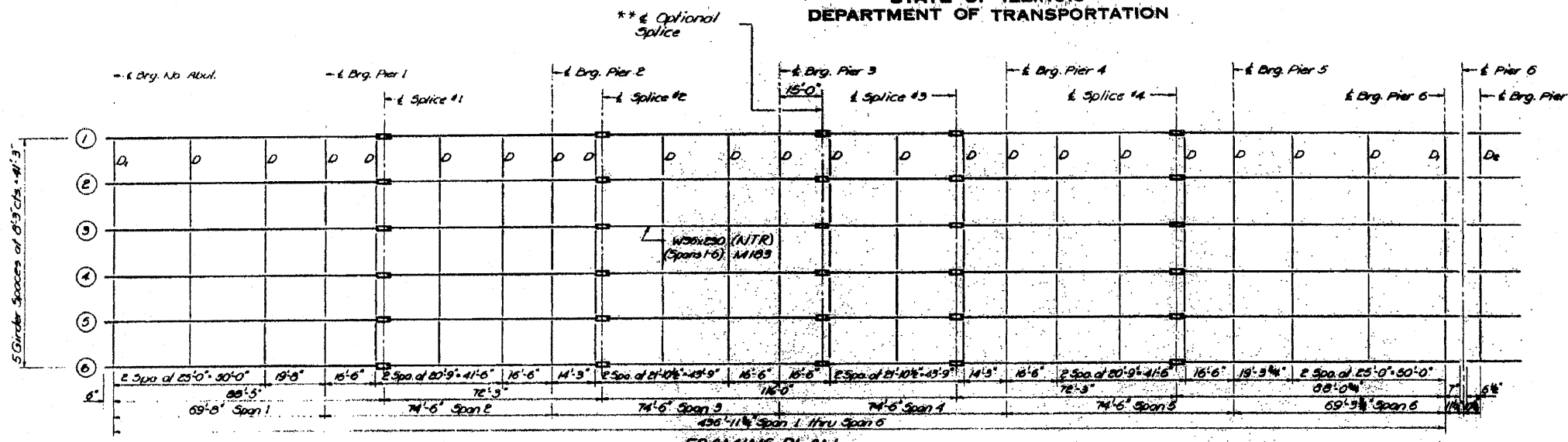

** The fabricator may place an optional splice 15'-0" from Pier 3. The splice shall have the same details as splices #1 thru #4, and the segment from splice #2 to splice #3 shall remain straight.

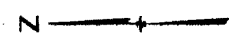
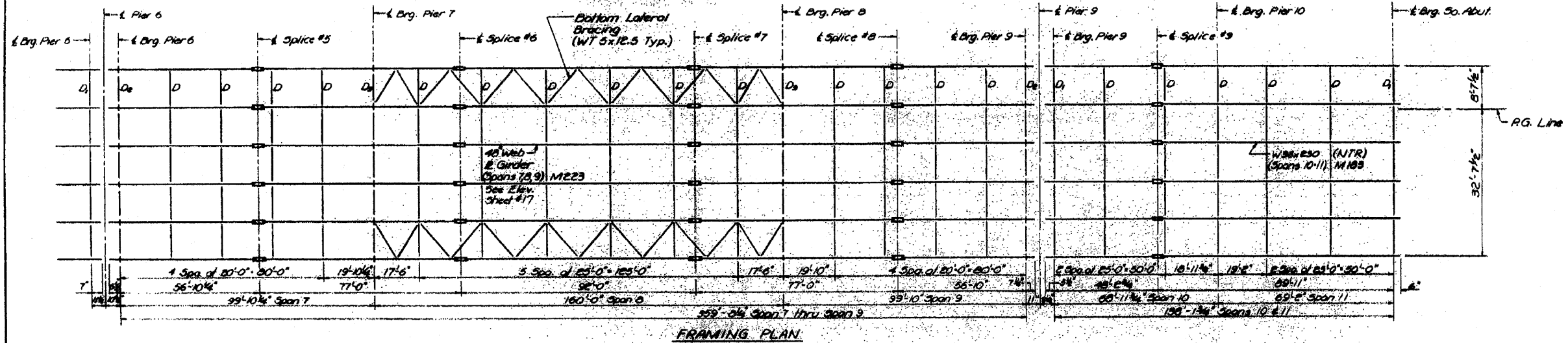

* TOP OF FLANGE ELEVATIONS

Beam No.	1. Bnc.	2. Bnc.	3. Bnc.	4. Bnc.	5. Bnc.	6. Bnc.	7. Bnc.	8. Bnc.	9. Bnc.	10. Bnc.	11. Bnc.
1	760.727	760.081	760.087	760.087	760.087	760.087	760.087	760.087	760.087	760.087	760.087
2	760.089	761.034	761.070	761.070	761.070	761.070	761.070	761.070	761.070	761.070	761.070
3	761.029	761.183	761.189	761.189	761.189	761.189	761.189	761.189	761.189	761.189	761.189
4	761.029	761.183	761.189	761.189	761.189	761.189	761.189	761.189	761.189	761.189	761.189
5	760.089	761.034	761.070	761.070	761.070	761.070	761.070	761.070	761.070	761.070	761.070
6	760.727	760.081	760.087	760.087	760.087	760.087	760.087	760.087	760.087	760.087	760.087

* TOP OF WEB ELEVATIONS

Beam No.	1. Bnc.	2. Bnc.	3. Bnc.	4. Bnc.	5. Bnc.	6. Bnc.	7. Bnc.	8. Bnc.	9. Bnc.	10. Bnc.	11. Bnc.
1	760.727	760.081	760.087	760.087	760.087	760.087	760.087	760.087	760.087	760.087	760.087
2	760.089	761.034	761.070	761.070	761.070	761.070	761.070	761.070	761.070	761.070	761.070
3	761.029	761.183	761.189	761.189	761.189	761.189	761.189	761.189	761.189	761.189	761.189
4	761.029	761.183	761.189	761.189	761.189	761.189	761.189	761.189	761.189	761.189	761.189
5	760.089	761.034	761.070	761.070	761.070	761.070	761.070	761.070	761.070	761.070	761.070
6	760.727	760.081	760.087	760.087	760.087	760.087	760.087	760.087	760.087	760.087	760.087

* TOP OF FLANGE ELEVATIONS

Beam No.	1. Bnc.	2. Bnc.	3. Bnc.	4. Bnc.	5. Bnc.	6. Bnc.	7. Bnc.	8. Bnc.	9. Bnc.	10. Bnc.	11. Bnc.
1	760.727	760.081	760.087	760.087	760.087	760.087	760.087	760.087	760.087	760.087	760.087
2	760.089	761.034	761.070	761.070	761.070	761.070	761.070	761.070	761.070	761.070	761.070
3	761.029	761.183	761.189	761.189	761.189	761.189	761.189	761.189	761.189	761.189	761.189
4	761.029	761.183	761.189	761.189	761.189	761.189	761.189	761.189	761.189	761.189	761.189
5	760.089	761.034	761.070	761.070	761.070	761.070	761.070	761.070	761.070	761.070	761.070
6	760.727	760.081	760.087	760.087	760.087	760.087	760.087	760.087	760.087	760.087	760.087

DESIGNED DAU KRULL
CHECKED MJR P.B. J.R.
DRAWN S.G. FERGUSON
CHECKED MJR P.B. J.R.

EXAMINED
PASSED
APPROVED

* For fabrication only, before any deflections

Note: NTR denotes steel that must conform to the Supplemental Requirements for Notch Toughness (Spec. 5).

STRUCTURAL STEEL
F.A.R.T. 401 SEC. 177-40-1
STEPHENSON COUNTY
SECTION 500-35-40

FOR INFORMATION ONLY

FILE NAME =	USER NAME = linkdj	DESIGNED -	REVISED -	STATE OF ILLINOIS DEPARTMENT OF TRANSPORTATION	Existing Bridge Plans Structure No. 089-0042	F.A.R.T. -	SECTION	COUNTY	TOTAL SHEETS	SHEET NO.
Q:\BR\Bridg Painting\Contracts\PAINTING\64G88\PLAEng.dgn		DRAWN -	REVISED -			var	D2 Bridge Painting 2011-2	various	25	19
PLOT SCALE = 50.0000' / IN.		CHECKED -	REVISED -			CONTRACT NO. 64G88		ILLINOIS FED. AID PROJECT		
PLOT DATE = Sat Jan 22 07:09:56 2011		DATE -	REVISED -			SCALE: _____	SHEET NO. ____ OF ____ SHEETS	STA. _____ TO STA. _____		

STATE OF ILLINOIS
DEPARTMENT OF TRANSPORTATION

DATE	DESIGNED	CHECKED	DRAWN	SHEET NO.
1/22/08	DAN KRULL	MJR P.B.	SG PRITCHARD	17
				35 SHEETS

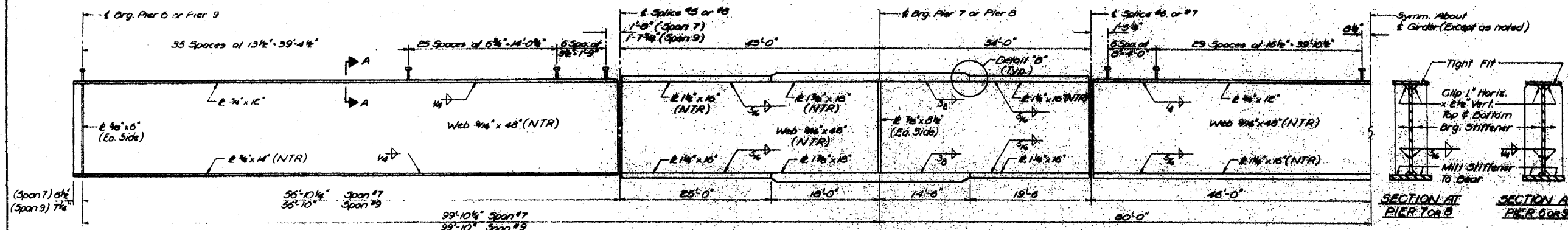

HALF GIRDER ELEVATION

NTR denotes steel that must conform to the Supplemental Requirements for Notch Toughness (Zone 2)

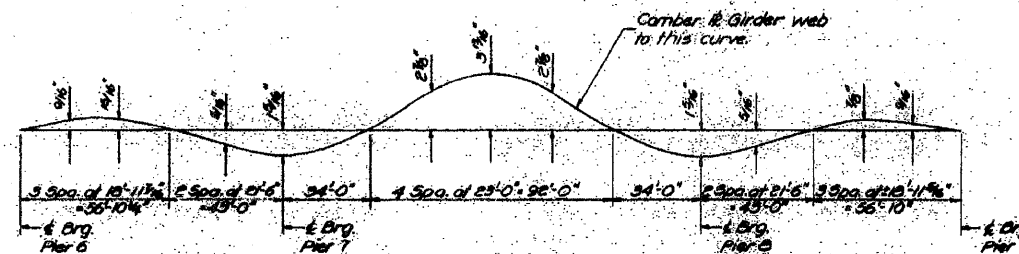
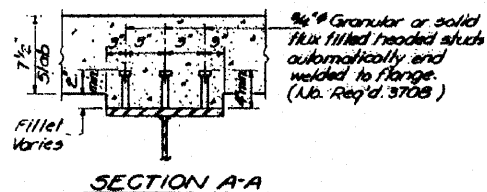

CAMBER DIAGRAM

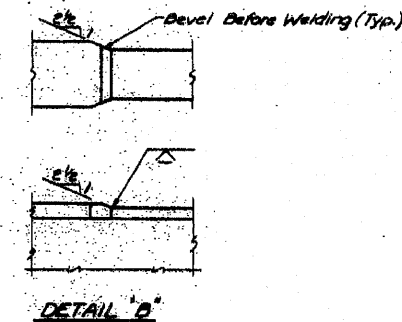

DETAIL 'B'

	04-34.1	05-34.2	06-34.3	07-34.4	08-34.5
I (in ⁴)	15000	15000	15000	15000	15000
S (in ³)	1353	1353	1353	1353	1353
M ₁ (K)	647.0	-340.4	355.1	-734.0	441.1
M ₂ (K)	1258.7	-1054.3	1100.7	-1013.0	1092.3
M ₃ (K)	326.1	250.3	270.2	271.2	280.3
M ₄ (K)	2241.8	2225.2	1730.0	2061.2	1808.1
V ₁ (K)	32.14	31.90	24.20	29.53	25.98

	04-34.1	05-34.2	06-34.3	07-34.4	08-34.5
I _s (in ⁴)	2741.3	2741.3	2741.3	2741.3	2741.3
S _s (in ³)	230.7	230.7	230.7	230.7	230.7
M ₁ (K)	647.0	-340.4	355.1	-734.0	441.1
M ₂ (K)	1258.7	-1054.3	1100.7	-1013.0	1092.3
M ₃ (K)	326.1	250.3	270.2	271.2	280.3
M ₄ (K)	2241.8	2225.2	1730.0	2061.2	1808.1
V ₁ (K)	32.14	31.90	24.20	29.53	25.98

	04-34.1	05-34.2	06-34.3	07-34.4	08-34.5
R ₁ (K)	1000	1000	1000	1000	1000
R ₂ (K)	1000	1000	1000	1000	1000
R ₃ (K)	1000	1000	1000	1000	1000
R ₄ (K)	1000	1000	1000	1000	1000

	04-34.1	05-34.2	06-34.3	07-34.4	08-34.5
R ₁ (K)	35.7	105.4	91.2	91.7	70.0
R ₂ (K)	23.0	51.2	51.2	41.0	91.4
R ₃ (K)	11.6	18.6	16.3	16.3	18.6
R ₄ (K)	85.3	106.8	176.1	174.1	92.9

I_s and S_s are the moment of inertia and section modulus of the steel section used in computing I_{TOTAL}.
I_c and S_c are the moment of inertia and section modulus of the composite section used in computing I_{TOTAL}.
V_R is the maximum 6" interval shear range in span used to determine shear connector spacing.
Moments shown in the tables are factored according to the formula M_u = 1.3(M₁ + M₂) + 1.67(M₃ + M₄)

FOR INFORMATION ONLY

DESIGNED DAN KRULL	EXAMINED
CHECKED MJR P.B.	DRAWN
DRAWN SG PRITCHARD	APPROVED
CHECKED MJR P.B.	

STRUCTURAL STEEL
F.A. 11-11 SEC. 17-10-1
STEPHENSON COUNTY
WATSON, ILLINOIS

FOR INFORMATION ONLY

STATE OF ILLINOIS
DEPARTMENT OF TRANSPORTATION

DATE	DESIGNED	CHECKED	DRAWN	PLT	SHEET NO. 18
	D.W. KNULL	J. K. RICHARDS	S.G. PERROWE	J. K. RICHARDS	24
					25 SHEETS

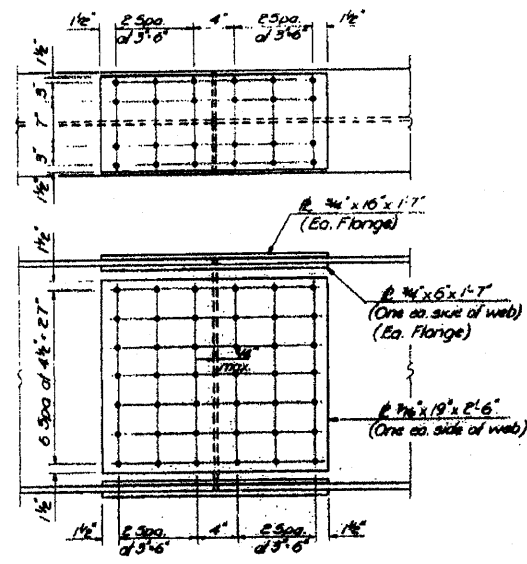

SPLICE #1 THRU #4
1/4" H.S. BOLTS THROUGHOUT
(M 183 Plate)

Note: All splice plates shall conform to the Supplemental Requirements for Notch Toughness (Zone 2)

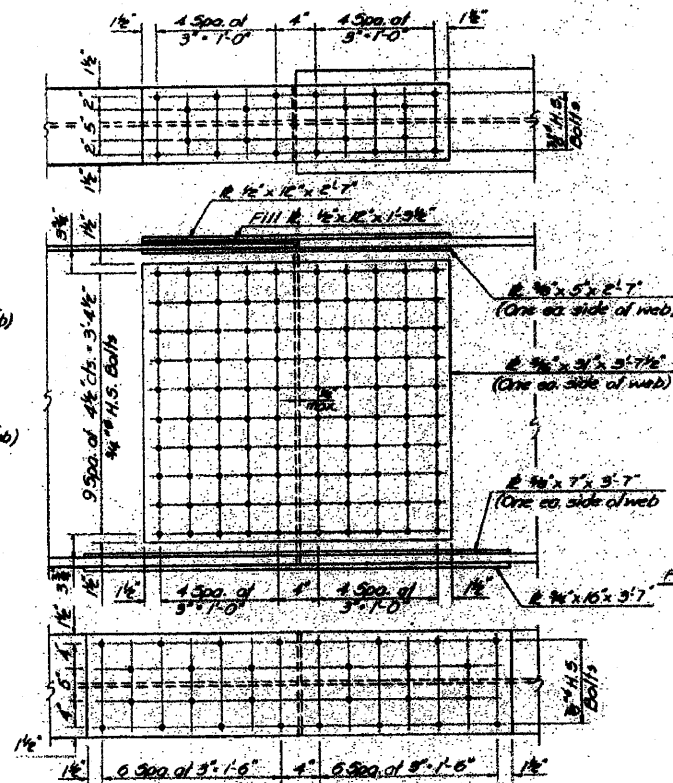

SPLICE #6 (Looking West)
SPLICE #7 (Looking East)
(M 223 Plates)

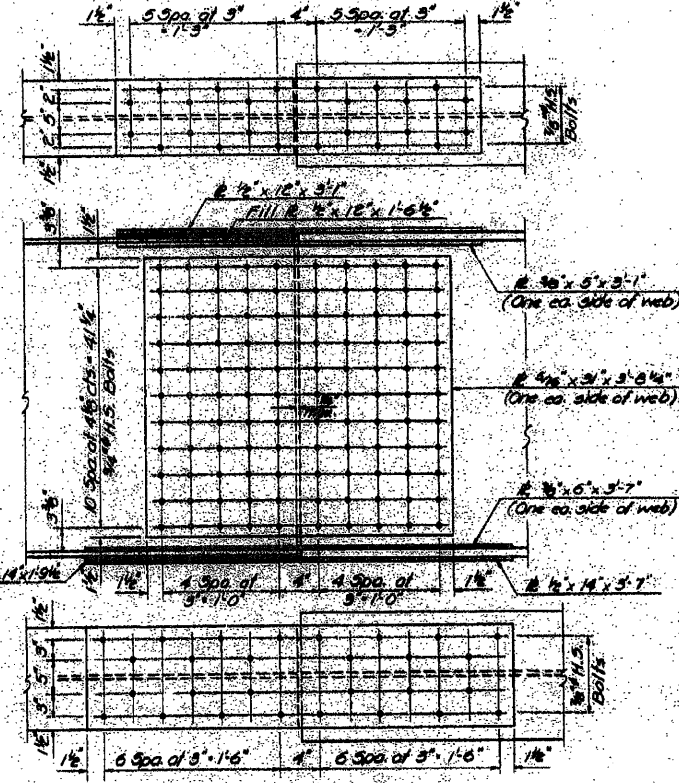

SPLICE #6 (Looking East)
SPLICE #8 (Looking West)
(M 223 Plates)

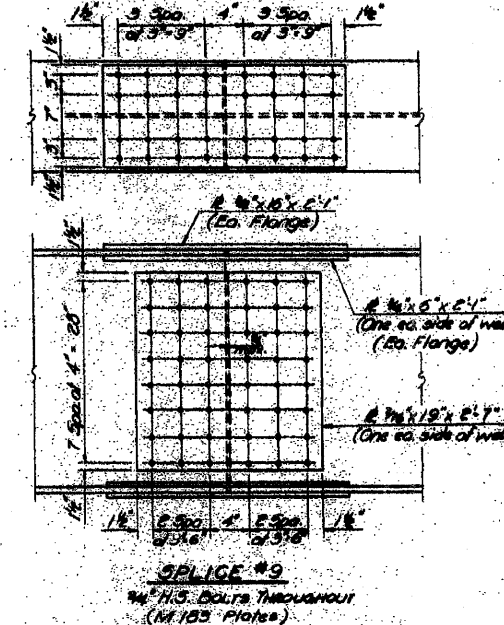

SPLICE #9
1/4" H.S. BOLTS THROUGHOUT
(M 183 Plates)

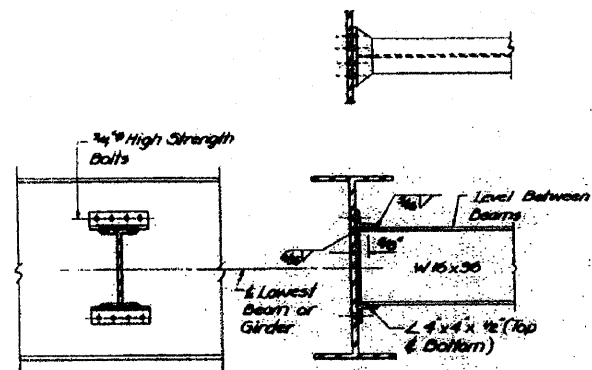
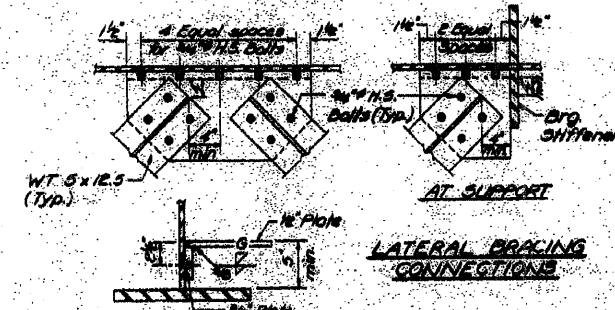

INTERIOR DIAPHRAGM-D
(200 Required)

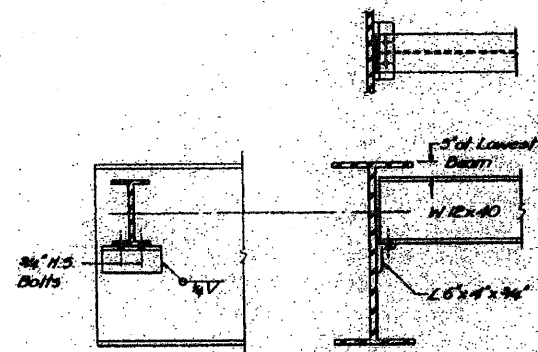

END DIAPHRAGM-D
(20 Required)

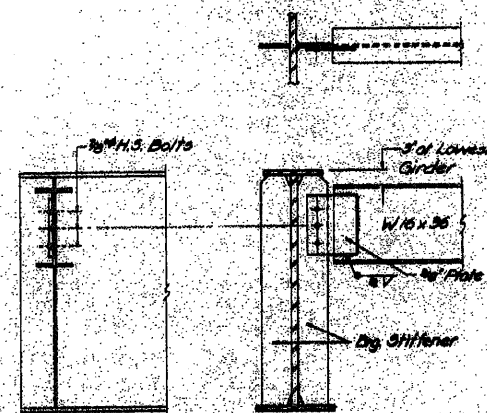

END DIAPHRAGM-D₂
(10 Required)

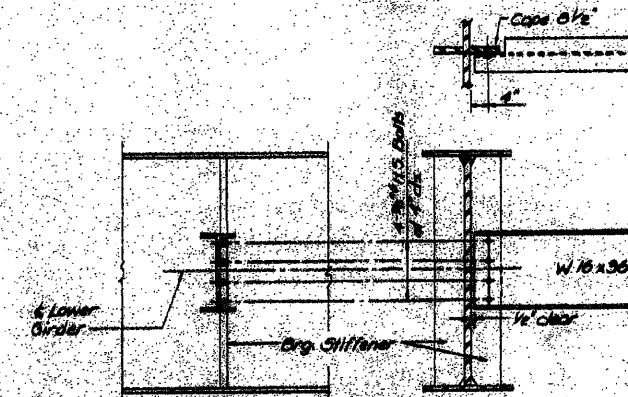

INTERIOR DIAPHRAGM-D₂
(10 Required)

DESIGNED	D.W. KNULL	DATE	10/20/00
CHECKED	J. K. RICHARDS	PLT SCALE	1/8" = 1'-0"
DRAWN	S.G. PERROWE	PLT DATE	Sat Jan 22 07:09:40 2011
CHECKED	J. K. RICHARDS		

NOTES

All holes used for the connection of diaphragms and lateral bracing shall be fabricated 3/16" oversized.

Hardened washers shall be required over all structural steel.

All contact surfaces of joints for the diaphragms and lateral bracing shall be free of paint or rust.

Diaphragms shall be fabricated from steel plates and angles.

STRUCTURAL STEEL
F.A. 101 - SEC. 177-40-1
SHERIDAN COUNTY
CONTRACT NO. 64C88

FILE NAME =	USER NAME = linkdj	DESIGNED -	REVISD -	STATE OF ILLINOIS DEPARTMENT OF TRANSPORTATION	Existing Bridge Plans Structure No. 089-0042	F.A. RTE.	SECTION	COUNTY	TOTAL SHEETS	SHEET NO.	
D:\BRV\Brdge Painting\Contract\PAINTING\64C88\PLN\eng.dgn		DRAWN -	REVISD -			var	D2 Bridge Painting 2011-2	various	25	21	
		CHECKED -	REVISD -			SCALE: _____	SHEET NO. _____ OF _____ SHEETS	STA. _____ TO STA. _____	CONTRACT NO. 64C88		
		DATE -	REVISD -			ILLINOIS FED. AID PROJECT					

FOR INFORMATION ONLY

STATE OF ILLINOIS
DEPARTMENT OF TRANSPORTATION

PROJECT NO.	DESIGNER	DATE	SHEET NO.	TOTAL SHEETS
401	Stephenson	48	25	35 SHEETS

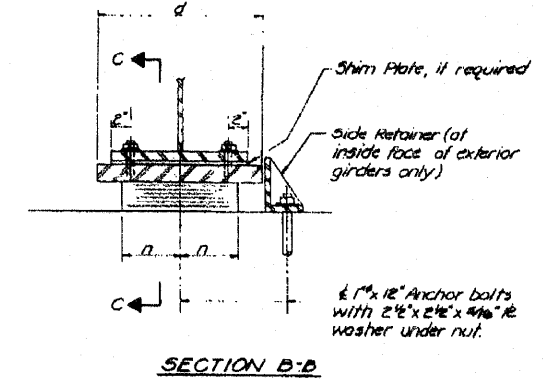
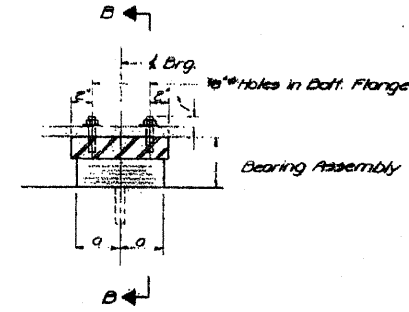
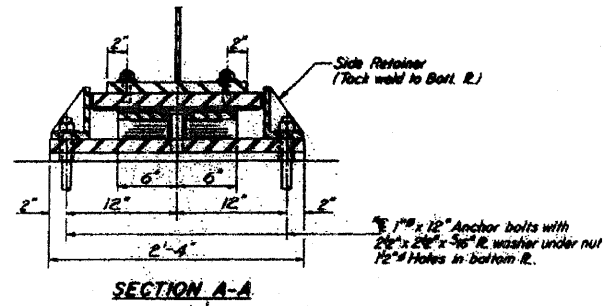
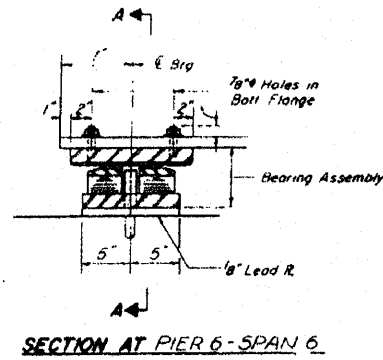

TYPE III ELASTOMERIC EXP. BRG. (M183 Plates)

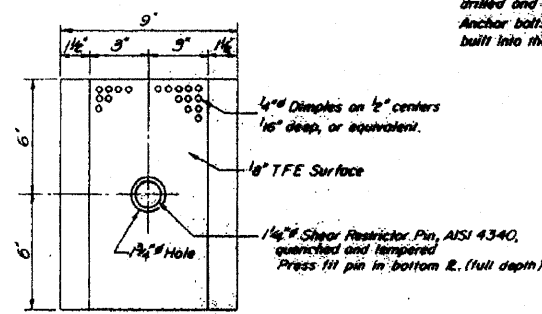
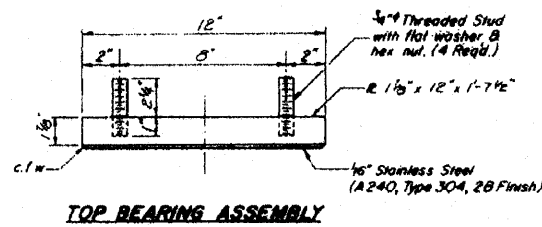

Note: After girders have been erected holes at expansion bearings shall be drilled and anchor bolts grouted in place. Anchor bolts of fixed bearings may be built into the masonry.

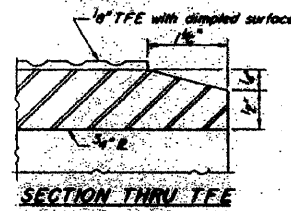
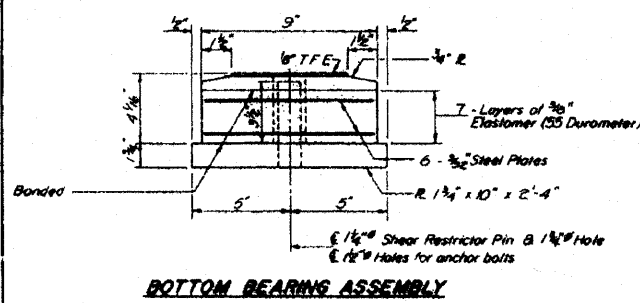

Note: The 1/4 inch TFE sheet shall be bonded directly to the top steel plate with a two-component, medium viscosity epoxy resin, conforming to the requirements of the Federal Specification MILM-A-134, Type I. The bond agent shall be applied on the full area of the contact surfaces.

Bonding of 1/4 inch TFE sheet during vulcanizing process will be permitted provided the process and method of adjusting assembly height is approved by the Engineer.

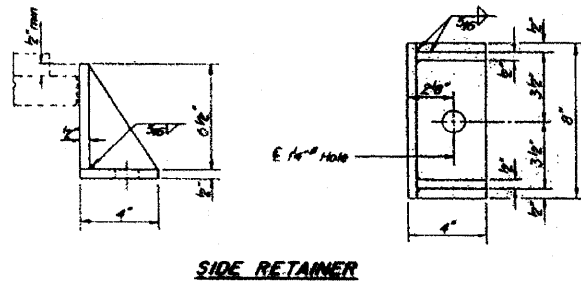

TABLE OF TYPE I DIMENSIONS

LOCATION	0	1	2	3	4	5	6	7	8	9	10	11	12	13	14	15	16	17	18
Pier 1	5 1/2	5 1/2	12	17 1/2	23	29 1/2	35 1/2	41 1/2	47 1/2	53 1/2	59 1/2	65 1/2	71 1/2	77 1/2	83 1/2	89 1/2	95 1/2	101 1/2	107 1/2
Pier 3	5 1/2	5 1/2	12	17 1/2	23	29 1/2	35 1/2	41 1/2	47 1/2	53 1/2	59 1/2	65 1/2	71 1/2	77 1/2	83 1/2	89 1/2	95 1/2	101 1/2	107 1/2
Pier 4	6	6	13	19	25	31	37	43	49	55	61	67	73	79	85	91	97	103	109
Pier 5	2 1/2	2 1/2	12	17 1/2	23	29 1/2	35 1/2	41 1/2	47 1/2	53 1/2	59 1/2	65 1/2	71 1/2	77 1/2	83 1/2	89 1/2	95 1/2	101 1/2	107 1/2
Pier 6 - Span 7	6	6	13	19	25	31	37	43	49	55	61	67	73	79	85	91	97	103	109
Pier 8	9	9	15	21	27	33	39	45	51	57	63	69	75	81	87	93	99	105	111
Pier 10	6 1/2	6 1/2	12 1/2	18 1/2	24 1/2	30 1/2	36 1/2	42 1/2	48 1/2	54 1/2	60 1/2	66 1/2	72 1/2	78 1/2	84 1/2	90 1/2	96 1/2	102 1/2	108 1/2

BILL OF MATERIAL

ITEM	UNIT	TOTAL
Elastomeric Bearing Assembly, Type I	Each	46
Elastomeric Bearing Assembly, Type III	Each	6

DESIGNED	DAN KRULL	EXAMINED	[Signature]
CHECKED	J. K.	PASSED	[Signature]
DRAWN	SG FERCHOW	APPROVED	[Signature]
CHECKED	J. K.	REVISIONS	

I-2-E3 4.1.79

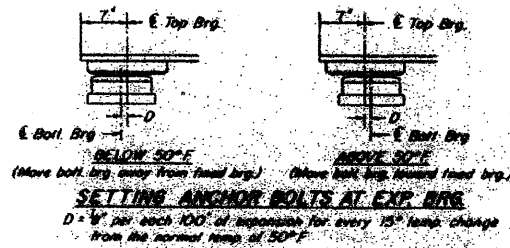

BEARING DETAILS
S.A. RT. 401 SEC. 177-40-1
STEPHENSON COUNTY
STATION 909+90.00

FILE NAME =	USER NAME = linkdj	DESIGNED -	REVISED -	STATE OF ILLINOIS DEPARTMENT OF TRANSPORTATION	Existing Bridge Plans Structure No. 089-0042	F.A. RTE. =	SECTION	COUNTY	TOTAL SHEETS	SHEET NO.
D:\BR\Bridg Painting\Contract\PAINTING\64088\PLAN\dgn		DRAWN -	REVISED -			var	D2 Bridge Painting 2011-2	various	25	22
PLOT SCALE = 50.0000 "/ IN.		CHECKED -	REVISED -							
PLOT DATE = Sat Jan 22 07:09:32 2011		DATE -	REVISED -			SCALE: _____	SHEET NO. _____ OF _____ SHEETS	STA. _____ TO STA. _____		CONTRACT NO. 64G88
										ILLINOIS FED. AID PROJECT

STATE OF ILLINOIS
DEPARTMENT OF PUBLIC WORKS & BUILDINGS
DIVISION OF HIGHWAYS

PROJECT NO.	SECTION	SHEET NO.	TOTAL SHEETS
2011-2	WINNEBAGO	9	4

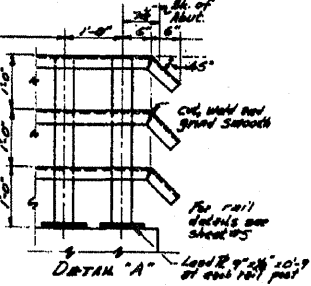
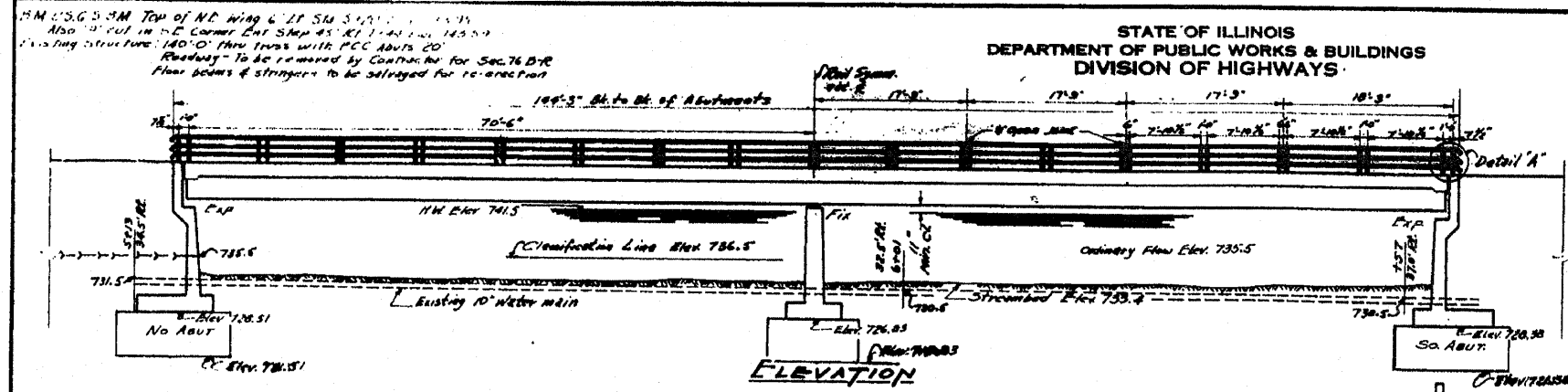

BORING DATA

BORING #	So. Elev.	Ground Surface	Soil Description
BORING #1	Sta. 5+89.82	746.10	Loose brown silty sand and gravel
BORING #1	Sta. 5+89.82	745.5	Soft black silty gravelly clay
BORING #1	Sta. 5+89.82	745.0	Loose brown silty sand and gravel
BORING #1	Sta. 5+89.82	744.5	Medium brown sub-angular well graded gravel
BORING #1	Sta. 5+89.82	744.0	Dense brown sub-angular well graded gravel
BORING #1	Sta. 5+89.82	743.5	Very dense gray fine sand
BORING #1	Sta. 5+89.82	743.0	Medium brown sub-angular well graded gravel
BORING #1	Sta. 5+89.82	742.5	Loose brown sub-angular poorly graded gravel
BORING #1	Sta. 5+89.82	742.0	Medium brown sub-angular poorly graded gravel
BORING #1	Sta. 5+89.82	741.5	Dense brown sub-angular well graded gravel
BORING #1	Sta. 5+89.82	741.0	Medium brown sub-angular well graded gravel
BORING #1	Sta. 5+89.82	740.5	Dense brown sub-angular well graded gravel
BORING #2	Sta. 5+89.82	746.10	Loose brown silty sand and gravel
BORING #2	Sta. 5+89.82	745.5	Soft black silty gravelly clay
BORING #2	Sta. 5+89.82	745.0	Loose brown silty sand and gravel
BORING #2	Sta. 5+89.82	744.5	Medium brown sub-angular well graded gravel
BORING #2	Sta. 5+89.82	744.0	Dense brown sub-angular well graded gravel
BORING #2	Sta. 5+89.82	743.5	Very dense gray fine sand
BORING #2	Sta. 5+89.82	743.0	Medium brown sub-angular well graded gravel
BORING #2	Sta. 5+89.82	742.5	Loose brown sub-angular poorly graded gravel
BORING #2	Sta. 5+89.82	742.0	Medium brown sub-angular poorly graded gravel
BORING #2	Sta. 5+89.82	741.5	Dense brown sub-angular well graded gravel
BORING #2	Sta. 5+89.82	741.0	Medium brown sub-angular well graded gravel
BORING #2	Sta. 5+89.82	740.5	Dense brown sub-angular well graded gravel
BORING #3	Sta. 5+89.82	746.10	Loose brown silty sand and gravel
BORING #3	Sta. 5+89.82	745.5	Soft black silty gravelly clay
BORING #3	Sta. 5+89.82	745.0	Loose brown silty sand and gravel
BORING #3	Sta. 5+89.82	744.5	Medium brown sub-angular well graded gravel
BORING #3	Sta. 5+89.82	744.0	Dense brown sub-angular well graded gravel
BORING #3	Sta. 5+89.82	743.5	Very dense gray fine sand
BORING #3	Sta. 5+89.82	743.0	Medium brown sub-angular well graded gravel
BORING #3	Sta. 5+89.82	742.5	Loose brown sub-angular poorly graded gravel
BORING #3	Sta. 5+89.82	742.0	Medium brown sub-angular poorly graded gravel
BORING #3	Sta. 5+89.82	741.5	Dense brown sub-angular well graded gravel
BORING #3	Sta. 5+89.82	741.0	Medium brown sub-angular well graded gravel
BORING #3	Sta. 5+89.82	740.5	Dense brown sub-angular well graded gravel

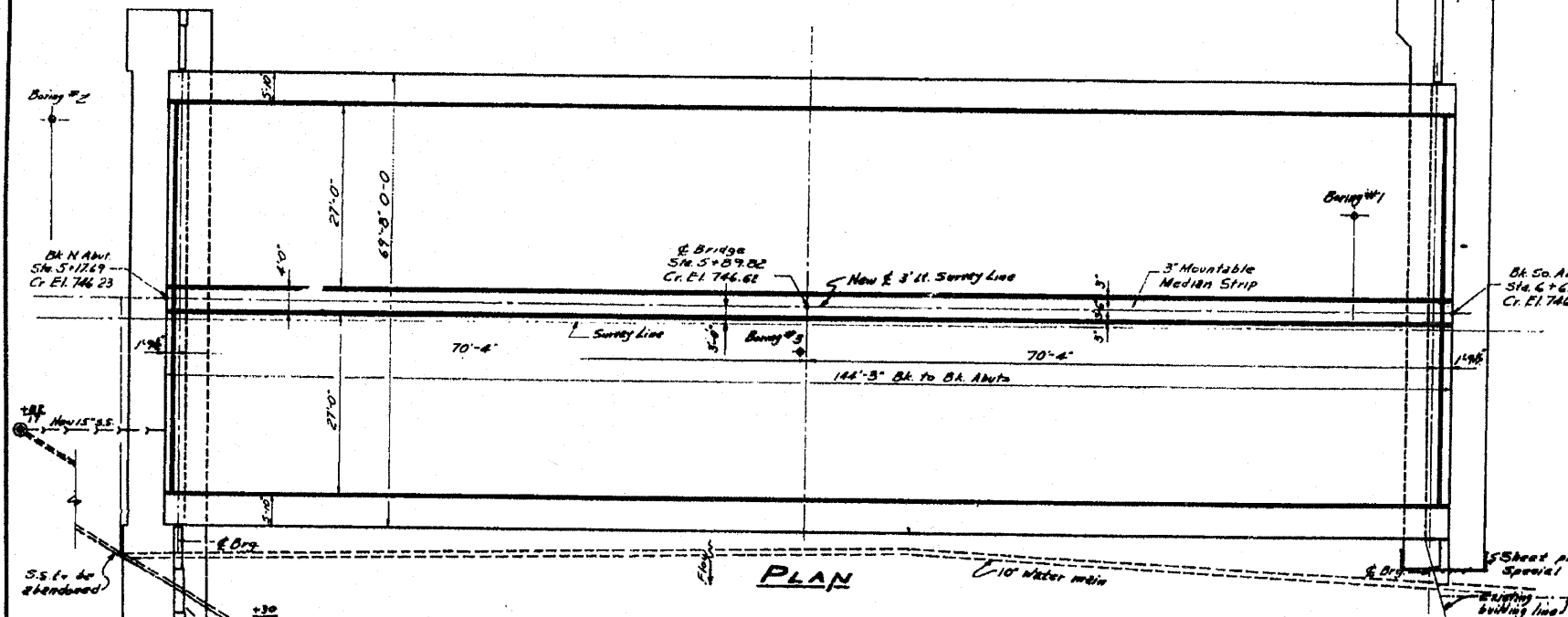

GENERAL NOTES

Class X Concrete shall be used throughout except in Pier. Class A Concrete shall be used in Pier. The Concrete Floor Slab shall be finished in accordance with Article 51.18(2) of the Standard Specifications. For Expansion Bolts see Special Provisions. The back of the Abutments and wing walls shall be waterproofed from the top of the footing to Elevation 746.0. Waterproofing shall be done in accordance with Article 52.30 of the Standard Specifications.

STATION 5+89.82
BUILT 195 BY
STATE OF ILLINOIS
S.B.I. RT. 2 SEC. 76-B-R
F.A. PROJ. F-142(29)
LOADING H20-516

NAME PLATE
See Std. 2113

DESIGN STRESSES

$f_s = 18,000 \text{ psi}$ Struct. Steel
 $f_s = 29,000 \text{ psi}$ Reinf.
 $f_c = 1,400 \text{ psi}$ Super
 $f_c = 800 \text{ psi}$ Substr.
 $n = 10$
Footing Pressure 1.7 tons/sq. ft. - Abut.
" " " " " " - Pier.
LOADING H20-516-44

TOTAL BILL OF MATERIAL

ITEM	QTY	SEC. A	SEC. B
Name Plate	Each	1	1
Rebar	Ln. Ft.	343	343
Structural Steel	Lbs.	344,000	344,000
Class A Concrete	Cu. Yds.	5216	5216
Class B Concrete	Cu. Yds.	138.9	138.9
Reinforcement Bars	Lbs.	71,700	71,700
Expansion Bolts	Each	10	10
Class A Expansion for Structures	Cu. Yds.	572	572
Class B Expansion for Structures	Cu. Yds.	1770	1770
Removal of Excess	Each	1	1
Steel Sheet Piling	Sq. Ft.	860	860
Steel Cold Chassis	Cu. Yds.	705	705

GENERAL PLAN & ELEVATION

TURTLE CREEK BRIDGE
S.B.I. RT. 2 SEC. 76-B-R
WINNEBAGO COUNTY
PROJECT-F-142(29)
STATION 5+89.82

DESIGNED	K. Ashmole	DATE	APRIL 9 2011
CHECKED	K. Ashmole	DATE	APRIL 9 2011
DRAWN	K.O.	DATE	APRIL 9 2011
CHECKED	H.L.O.	DATE	APRIL 9 2011

WATERWAY INFORMATION

Drainage Area: 160,000 Acres
Character: _____
Opening Equip: 1040 Sq. Ft.
Present Opening: 1030 Sq. Ft.
Proposed Opening: 1033 Sq. Ft.

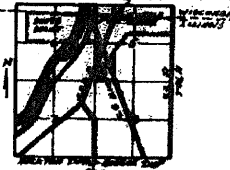

FOR INFORMATION ONLY

FILE NAME =	USER NAME = linkdj	DESIGNED -	REVISED -	STATE OF ILLINOIS DEPARTMENT OF TRANSPORTATION	Existing Bridge Plans Structure No. 101-0003	F.A. RTE. =	SECTION	COUNTY	TOTAL SHEETS	SHEET NO.
C:\NBR\Bridge Painting\Contracts\PAINTING\64488\PL\Neng.dgn		DRAWN -	REVISED -			var	D2 Bridge Painting 2011-2	WINNEBAGO	25	23
PLOT SCALE = 50.0000' / IN.		CHECKED -	REVISED -							
PLOT DATE = Sat Jan 22 07:00:23 2011		DATE	REVISED							CONTRACT NO. 64688
						SCALE:	SHEET NO. OF SHEETS	STA. TO STA.		ILLINOIS FED. AID PROJECT

STATE OF ILLINOIS
DEPARTMENT OF PUBLIC WORKS & BUILDINGS
DIVISION OF HIGHWAYS

DATE	NO.	BY	CHKD.	APPD.	SHEET
2/28/57	76BR	WINNEBAGO	10	5	2
					6 of 5

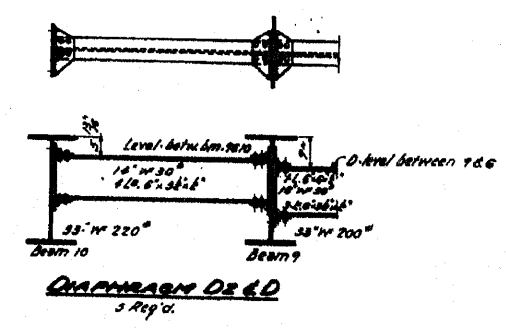
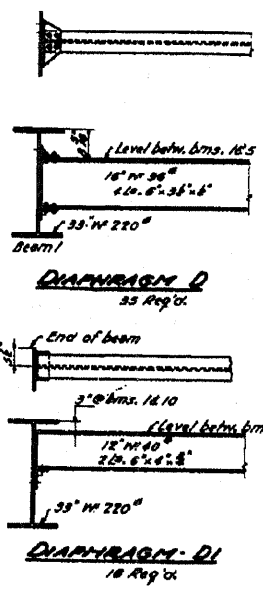
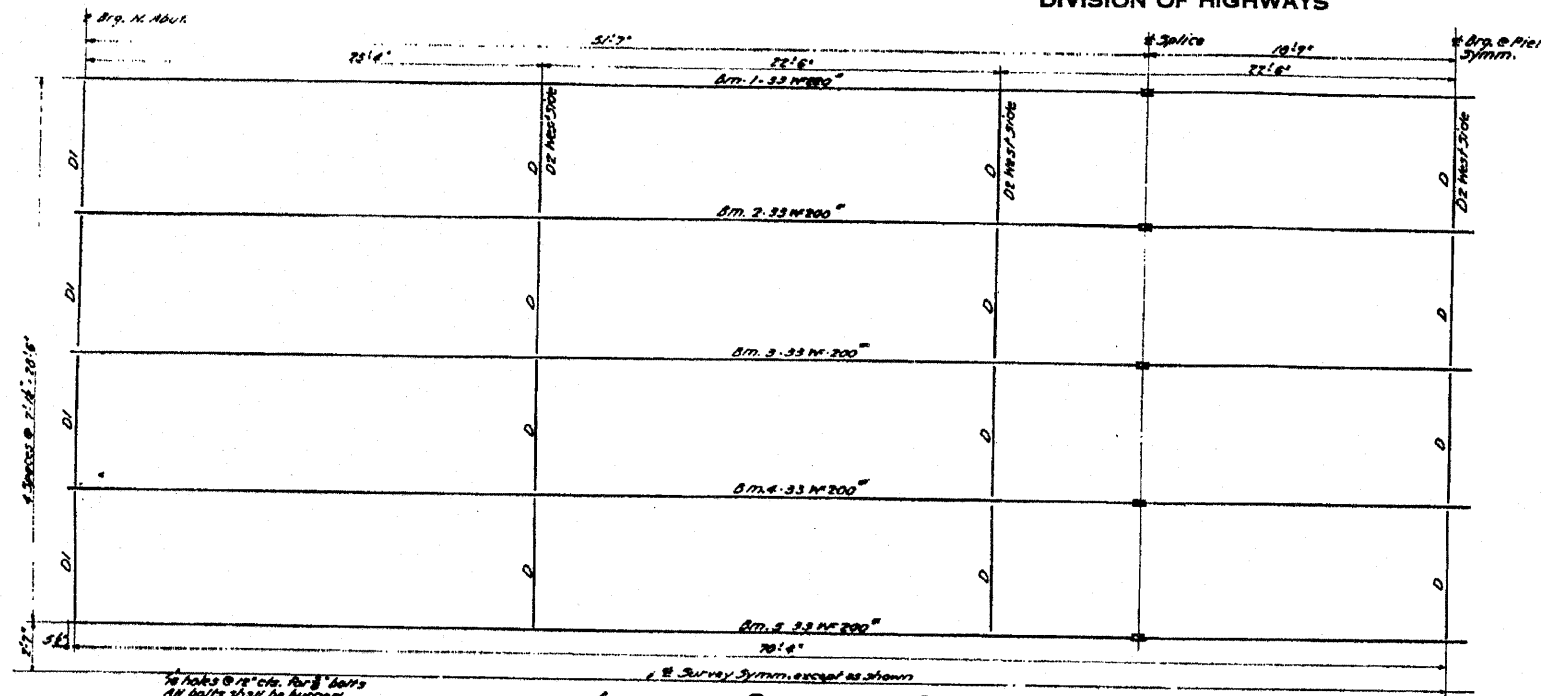

GENERAL NOTES
All rivets 5" and anchor bolts 1/2" except as noted.
All I-beam splices shall be subspliced and may be made for 8" rivets, but 10" rivets are preferred.
All I-beams shall be shop assembled to their proper grade and adjusted with or without diaphragms and remain unadjusted for inspection.
All Structural Steel shall be inspected by the Illinois Division of Highways before painting. Structural Steel shall receive one side coat of red lead paint furnished and applied by the Contractor for Sec. 70-1.2.
All rivets, bolts, nuts, washers, plates and anchor bolts shall be furnished painted and applied in accordance with Art 31.10 of the Standard Specifications and are subject to the payment of Structural Steel Anchor Bolts shall be set in form of quality cylinders over supports.
Structural steel shall receive two side coats of aluminum paint furnished and applied by the Contractor for Sec. 70-1.2.
Paint that has been used on Structural Steel except that anchors shall not be painted.

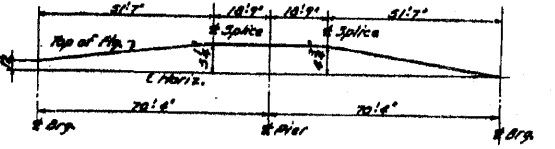
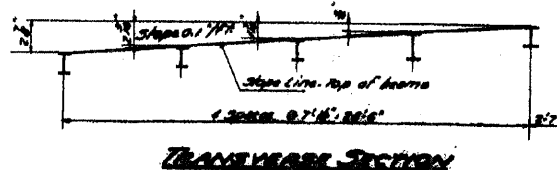
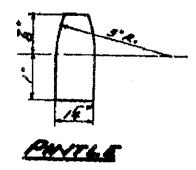
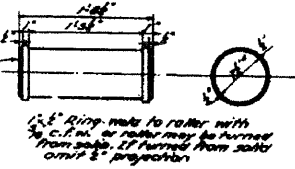
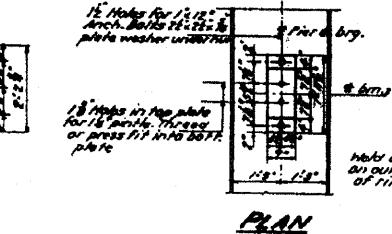
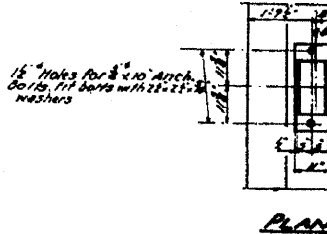
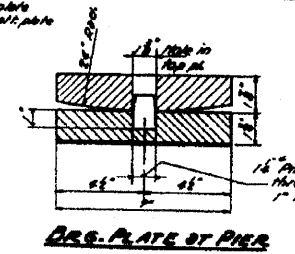
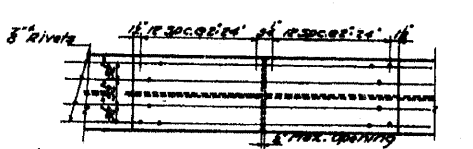
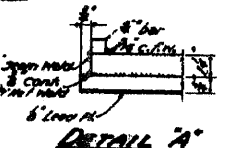
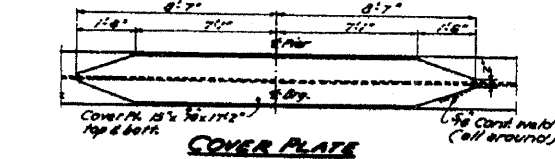
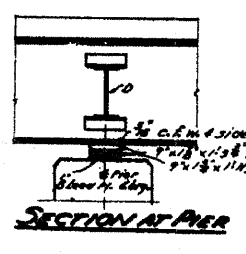
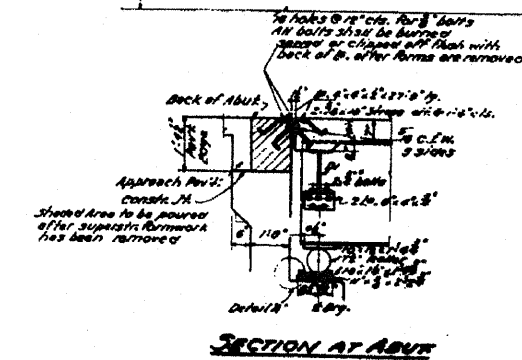

DESIGNED	K. O. Columbus
CHECKED	2/1/57
DRAWN	K. O.
CHECKED	K. O.

APRIL 9 1957

**STRUCTURAL STEEL DETAILS
DUBUE COUNTY BRIDGE
S. HARRIS & SONS
WINNEBAGO COUNTY
ST. LOUIS, MO.**

FOR INFORMATION ONLY

FILE NAME =	USER NAME = linkdj	DESIGNED -	REVISED -	STATE OF ILLINOIS DEPARTMENT OF TRANSPORTATION	Existing Bridge Plans Structure No. 101-0003	F.A. RTE:	SECTION	COUNTY	TOTAL SHEETS	SHEET NO.
OR:BR:Bridge Painting\Contracts\PAINTING\64088\PLAN.dgn	DESIGNED -	REVISED -	REVISED -			var	D2 Bridge Painting 2011-2	Various	25	24
PLOT SCALE = 50.0000' / IN.	CHECKED -	REVISED -	REVISED -			CONTRACT NO. 64C88				
PLOT DATE = Sat Jan 22 07:09:16 2011	DATE -	REVISED -	REVISED -			[ILLINOIS] FED. AID PROJECT				

STATE OF ILLINOIS
DEPARTMENT OF PUBLIC WORKS & BUILDINGS
DIVISION OF HIGHWAYS

DATE	NO.	BY	CHKD.	APP'D.	SHEET NO. 3
4-11-21	10	WINNEBAGO	9	10	65' ETS
PROJECT NO. 101-0003					

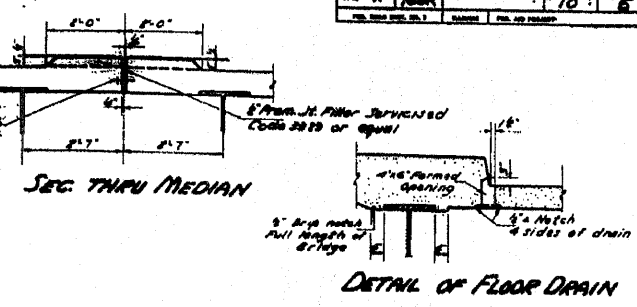
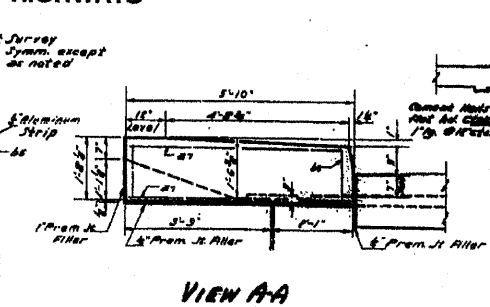
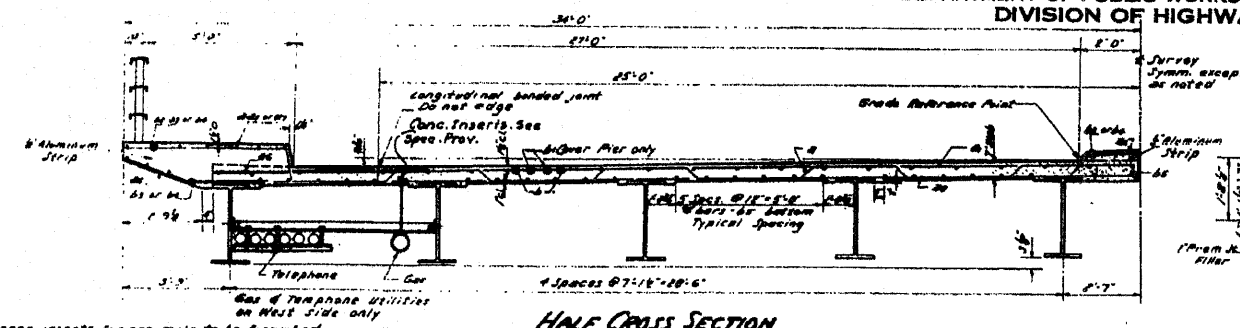

Hanger inserts for gas main to be furnished and installed by CONTRACTOR. Cost to be incidental. All material used to hang telephone conduits shall be furnished and installed by Wisconsin Telephone Co.

METHOD OF DETERMINING FILLET HEIGHT-'x'
After all structural steel has been erected, elevations of the top flanges of the beams shall be taken at intervals not to exceed 10 ft. From these elevations, the amount of deflection for these points, determined from Dead load Deflection Diagram. The elevation is obtained subtracted from the theoretical grade elevations minus floor thickness equals the fillet height above top of beam.

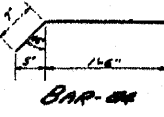
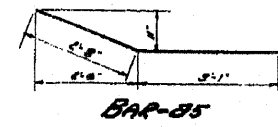
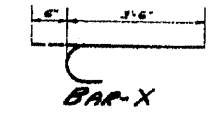
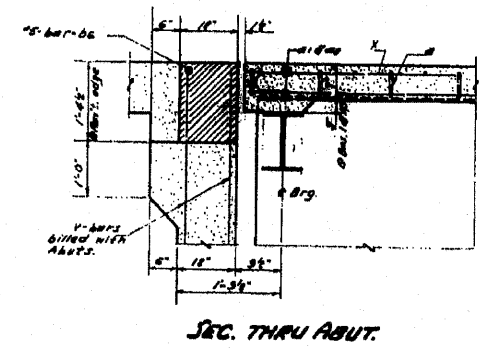
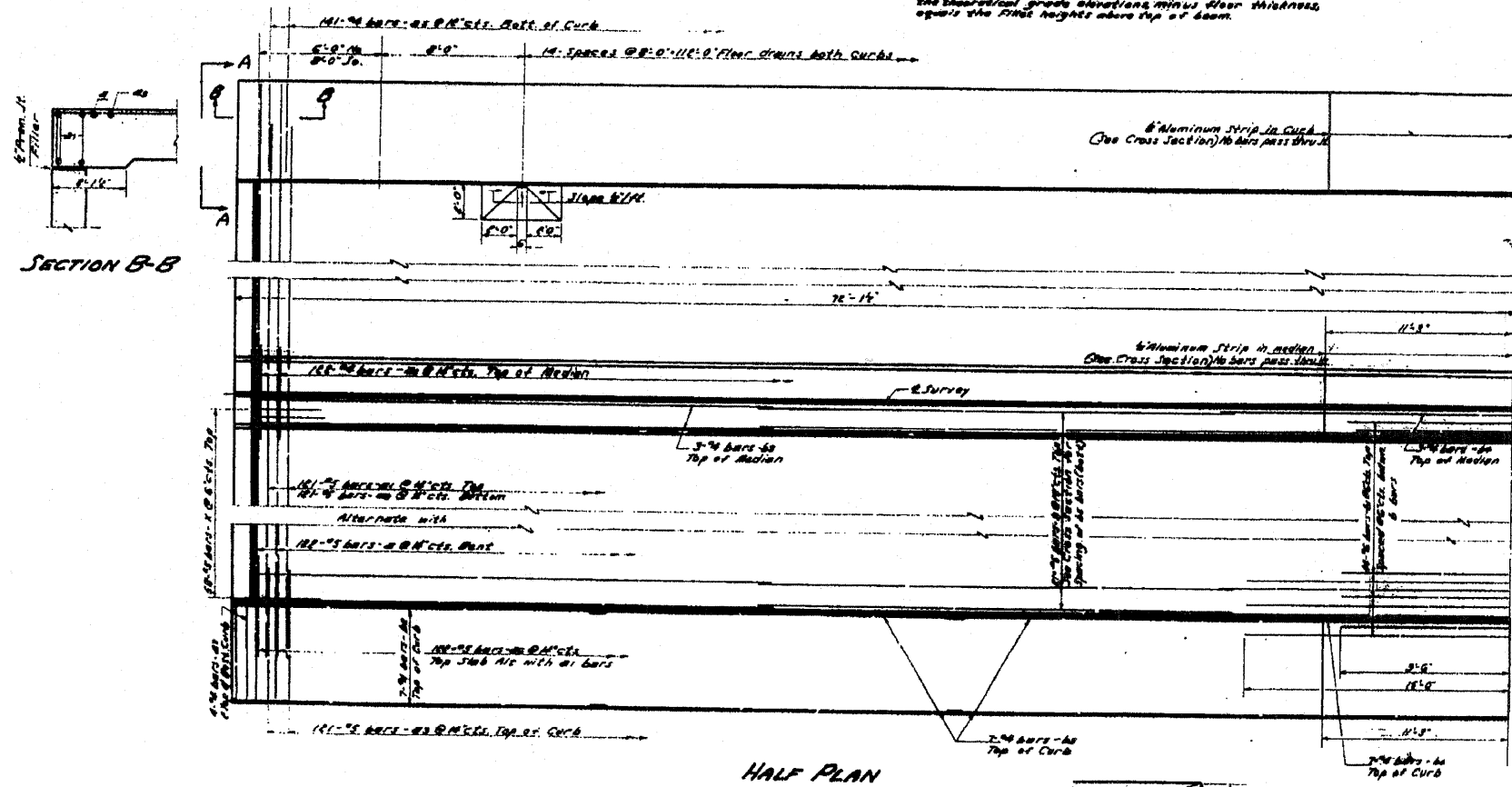

BILL OF MATERIAL
SUPERSTRUCTURE

BAR NO.	SIZE	LENGTH	SHAPE
1	1/2"	25'	3x6"
2	1/2"	25'	3x6"
3	1/2"	25'	3x6"
4	1/2"	25'	3x6"
5	1/2"	25'	3x6"
6	1/2"	25'	3x6"
7	1/2"	25'	3x6"
8	1/2"	25'	3x6"
9	1/2"	25'	3x6"
10	1/2"	25'	3x6"
11	1/2"	25'	3x6"
12	1/2"	25'	3x6"
13	1/2"	25'	3x6"
14	1/2"	25'	3x6"
15	1/2"	25'	3x6"
16	1/2"	25'	3x6"
17	1/2"	25'	3x6"
18	1/2"	25'	3x6"
19	1/2"	25'	3x6"
20	1/2"	25'	3x6"
21	1/2"	25'	3x6"
22	1/2"	25'	3x6"
23	1/2"	25'	3x6"
24	1/2"	25'	3x6"
25	1/2"	25'	3x6"
26	1/2"	25'	3x6"
27	1/2"	25'	3x6"
28	1/2"	25'	3x6"
29	1/2"	25'	3x6"
30	1/2"	25'	3x6"
31	1/2"	25'	3x6"
32	1/2"	25'	3x6"
33	1/2"	25'	3x6"
34	1/2"	25'	3x6"
35	1/2"	25'	3x6"
36	1/2"	25'	3x6"
37	1/2"	25'	3x6"
38	1/2"	25'	3x6"
39	1/2"	25'	3x6"
40	1/2"	25'	3x6"
41	1/2"	25'	3x6"
42	1/2"	25'	3x6"
43	1/2"	25'	3x6"
44	1/2"	25'	3x6"
45	1/2"	25'	3x6"
46	1/2"	25'	3x6"
47	1/2"	25'	3x6"
48	1/2"	25'	3x6"
49	1/2"	25'	3x6"
50	1/2"	25'	3x6"
51	1/2"	25'	3x6"
52	1/2"	25'	3x6"
53	1/2"	25'	3x6"
54	1/2"	25'	3x6"
55	1/2"	25'	3x6"
56	1/2"	25'	3x6"
57	1/2"	25'	3x6"
58	1/2"	25'	3x6"
59	1/2"	25'	3x6"
60	1/2"	25'	3x6"
61	1/2"	25'	3x6"
62	1/2"	25'	3x6"
63	1/2"	25'	3x6"
64	1/2"	25'	3x6"
65	1/2"	25'	3x6"
66	1/2"	25'	3x6"
67	1/2"	25'	3x6"
68	1/2"	25'	3x6"
69	1/2"	25'	3x6"
70	1/2"	25'	3x6"
71	1/2"	25'	3x6"
72	1/2"	25'	3x6"
73	1/2"	25'	3x6"
74	1/2"	25'	3x6"
75	1/2"	25'	3x6"
76	1/2"	25'	3x6"
77	1/2"	25'	3x6"
78	1/2"	25'	3x6"
79	1/2"	25'	3x6"
80	1/2"	25'	3x6"
81	1/2"	25'	3x6"
82	1/2"	25'	3x6"
83	1/2"	25'	3x6"
84	1/2"	25'	3x6"
85	1/2"	25'	3x6"
86	1/2"	25'	3x6"
87	1/2"	25'	3x6"
88	1/2"	25'	3x6"
89	1/2"	25'	3x6"
90	1/2"	25'	3x6"
91	1/2"	25'	3x6"
92	1/2"	25'	3x6"
93	1/2"	25'	3x6"
94	1/2"	25'	3x6"
95	1/2"	25'	3x6"
96	1/2"	25'	3x6"
97	1/2"	25'	3x6"
98	1/2"	25'	3x6"
99	1/2"	25'	3x6"
100	1/2"	25'	3x6"

Class X Concrete Cu 100 27.8
Reinforcement Bars 141 48360
Structural Steel 169 348810
Metal Handrail 10.0 790

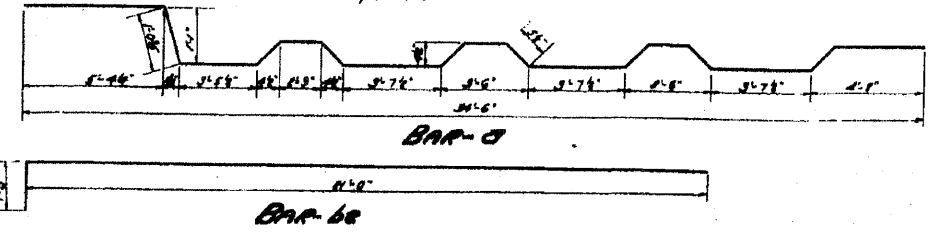
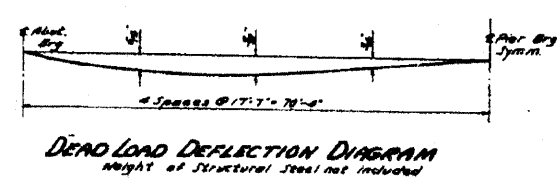

DESIGNED	K. W. [Signature]
CHECKED	[Signature]
DRAWN	K. W. [Signature]
CHECKED	[Signature]

APRIL 9 1957
DESIGNED K. W. [Signature]
DRAWN K. W. [Signature]
CHECKED [Signature]

FOR INFORMATION ONLY