

GENERAL NOTES

1. ALL TRAFFIC CONTROL DEVICES SHALL BE FURNISHED, ERECTED AND MAINTAINED BY THE CONTRACTOR.
2. LOCATIONS OF TRAFFIC CONTROL DEVICES MAY BE ADJUSTED BY THE ENGINEER.
3. ALL TRAFFIC CONTROL SHOWN ON THIS SHEET SHALL BE PAID FOR AT THE CONTRACT LUMP SUM PRICE FOR WIDTH RESTRICTION SIGNING.
4. ALL SIGNS SHALL BE POST MOUNTED UNLESS OTHERWISE DIRECTED.
5. ALL SIGNS SHOWN ORANGE (O) SHALL BE FLUORESCENT ORANGE.

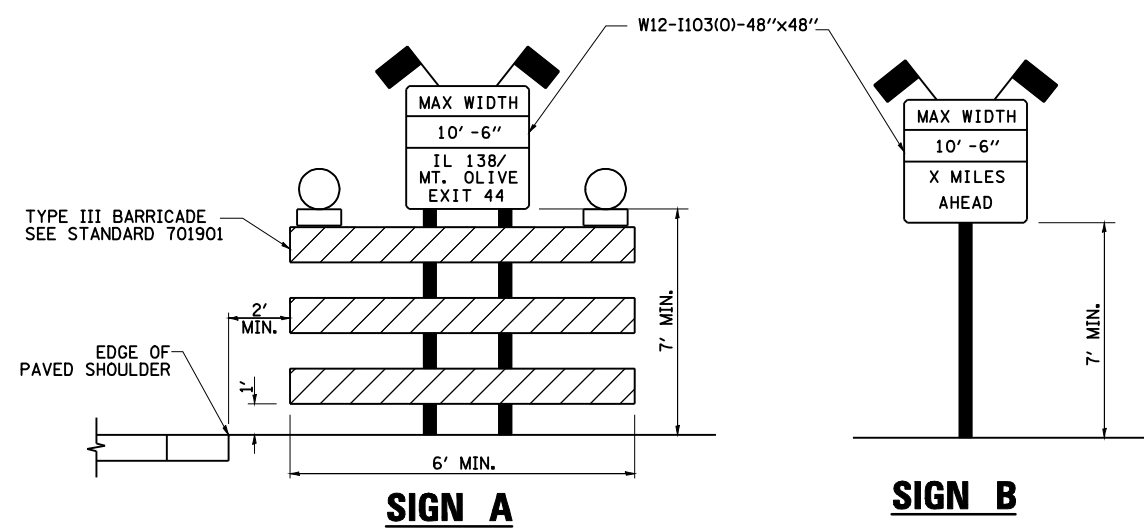

BLANK, WESSELINK, COOK & ASSOCIATES
ENGINEERS - CONSULTANTS
DECATUR, ILLINOIS

FILE NAME =	USER NAME = coxte	DESIGNED -	REVISED -
et:\pwork\pwork\coxte\d0258400\067292	sht-ConstructionSign.dgn	DRAWN -	REVISED -
	PLOT SCALE = 1250.0000 "/ IN.	CHECKED -	REVISED -
	PLOT DATE = Feb-07-2011 02:04:49PM	DATE -	REVISED -

**STATE OF ILLINOIS
DEPARTMENT OF TRANSPORTATION**

MAXIMUM WIDTH SIGN LOCATION			
SCALE:	SHEET NO. 7 OF 7 SHEETS	STA.	TO STA.

F.A. RTE.	SECTION	COUNTY	TOTAL SHEETS	SHEET NO.
55	(59,68)RS-3, BR	MACOUPIN	137	94
CONTRACT NO. 72921			ILLINOIS FED. AID PROJECT	