

STATE OF ILLINOIS
DEPARTMENT OF TRANSPORTATION

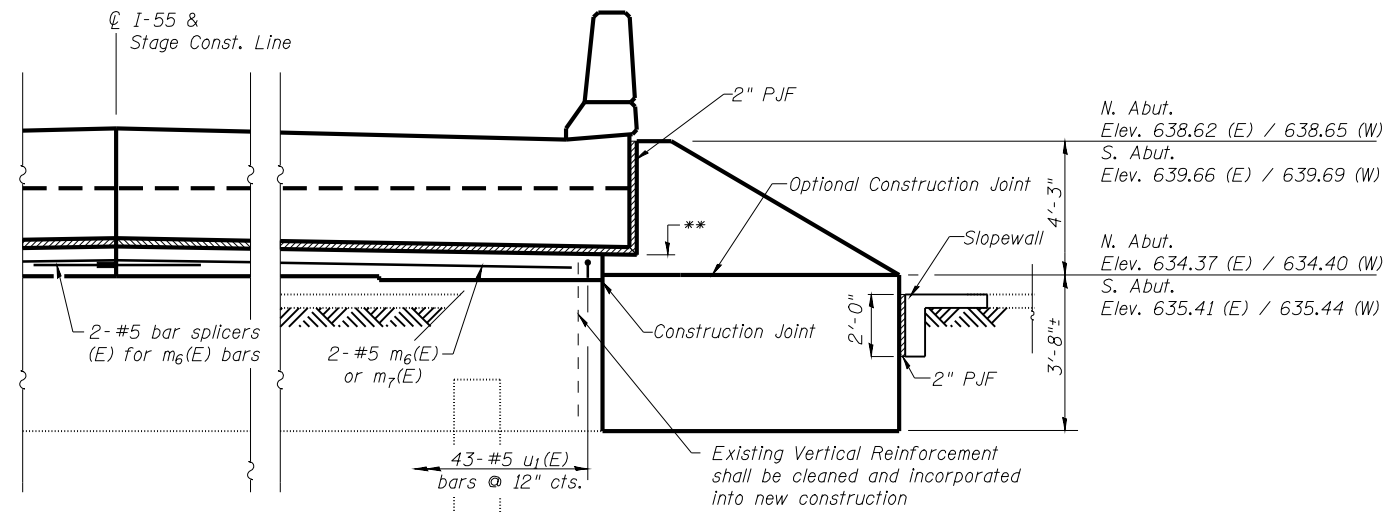

ELEVATION

South Abut. (Looking South)
(North Abut. Similar)

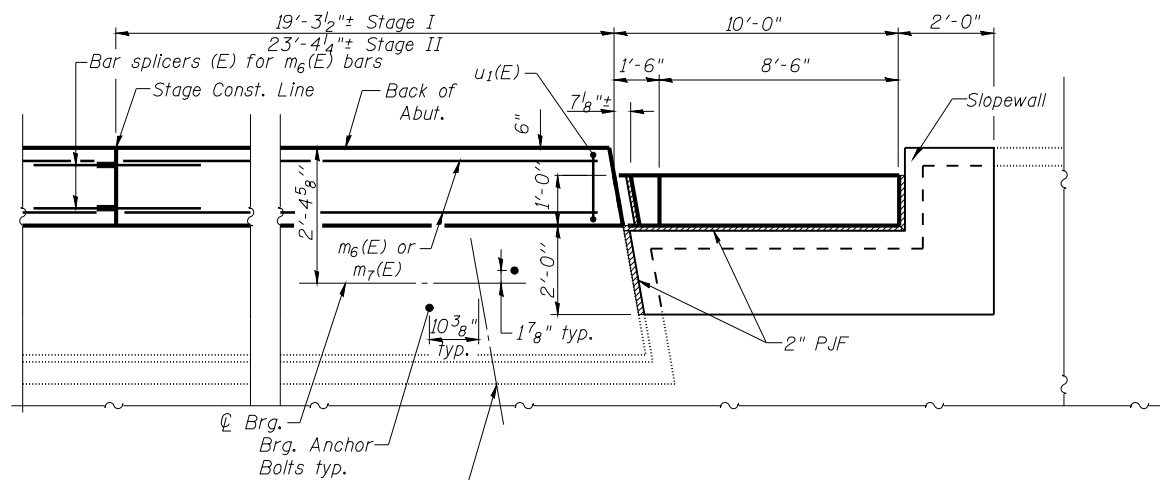

PLAN

South Abut. Shown
(North Abut. Similar)

** N. Abut. Elev. 635.04 (E)
N. Abut. Elev. 635.07 (W)

S. Abut. Elev. 636.08 (E)
S. Abut. Elev. 636.11 (W)

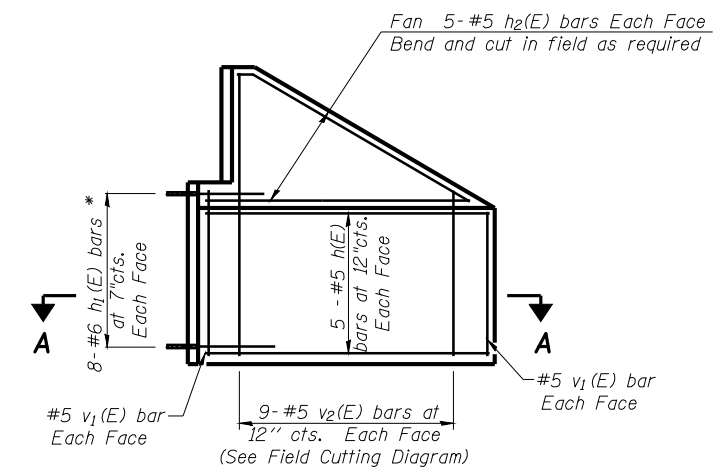

SECTION A-A

* Epoxy grout #6 bars in 1" holes 9" min. into existing abutment. All work shall be in accordance with Section 584 of the Standard Specifications. All work shall be inspected and approved by engineer. The cost of this work including all materials & labor shall be included in the cost per cu. yd. of Concrete Structures.

Note:
Slope wall shall be reinforced with welded wire fabric, 6 in. x 6 in. - W4.0 x W4.0, weighing 58 lbs. per 100 sq. ft.

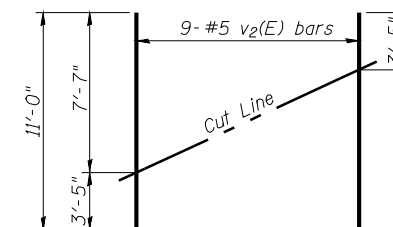

FIELD CUTTING DIAGRAM

Order v2(E) full length. Cut as shown and use remainder of bars in opposite face.

BILL OF MATERIAL

(2 Locations)

Bar	No.	Size	Length	Shape
h(E)	40	#5	9'-6"	—
h1(E)	64	#6	6'-0"	—
h2(E)	40	#5	10'-0"	—
m6(E)	4	#5	23'-0"	—
m7(E)	4	#5	18'-11"	—
u1(E)	86	#5	2'-5"	□
v1(E)	8	#5	4'-4"	—
v2(E)	36	#5	11'-0"	—
v3(E)	8	#5	3'-4"	—
Structure Excavation		Cu. Yd.	22	
Concrete Structures		Cu. Yd.	12.3	
Reinforcement Bars, Epoxy Coated		Pound	2,260	
Slope wall, 4 inch		Sq. Yd.	6	
Bar Splicers		Each	4	

**WINGWALL AND SLOPEWALL DETAILS
STRUCTURE NO. 059-0041 (N.B.)**

SHEET NO. 29	F.A.I. RTE.	SECTION	COUNTY	TOTAL SHEETS	SHEET NO.
31 SHEETS	55	(59, 68)RS-3, BR	Macoupin	137	136
CONTRACT NO. 72921					
FED. ROAD DIST. NO. 6 ILLINOIS FED. AID PROJECT					