

**TYPICAL CROSS SECTION - IL. RTE. 29**

STA. 602+10.93 TO STA. 665+40.92  
 STA. 690+40.92 TO STA. 698+40.92

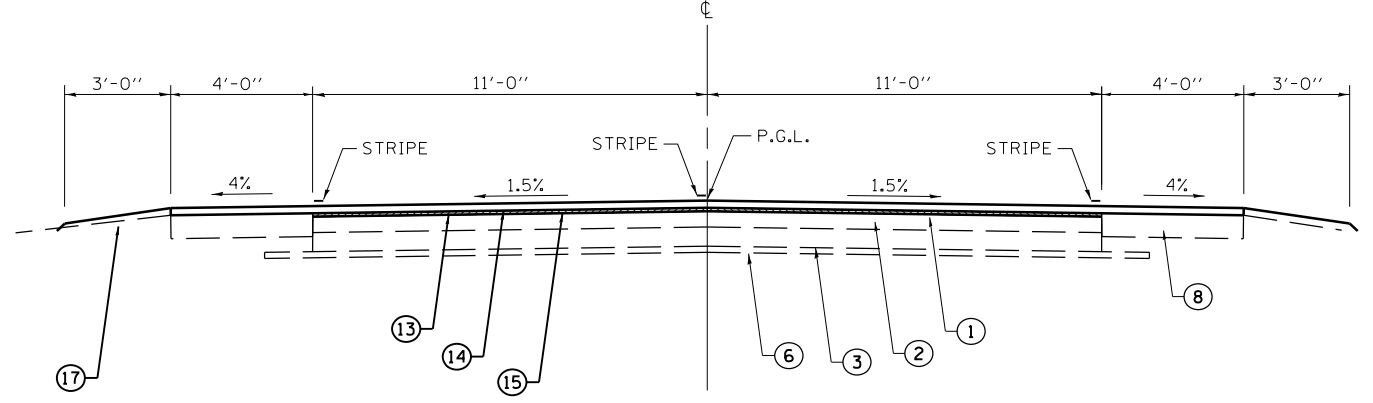

**TYPICAL CROSS SECTION - IL. RTE. 29**

STA. 665+40.92 TO STA. 690+40.92  
 STA. 698+40.92 TO STA. 732+50.94

**LEGEND**

- |  |  |
|--|--|
| <ul style="list-style-type: none"> <li>① EXISTING HMA SURFACE COURSE (VARIABLE DEPTH)</li> <li>② EXISTING HMA BINDER COURSE (VARIABLE DEPTH)</li> <li>③ EXISTING P.C.C. PAVEMENT 9"-6"-9"</li> <li>④ EXISTING HMA BASE COURSE WIDENING (VARIABLE DEPTH)</li> <li>④A EXISTING REFLECTIVE CRACK CONTROL TREATMENT</li> <li>⑤ EXISTING GRANULAR OR BASE COURSE, TYPE A 9"</li> <li>⑥ EXISTING SUBBASE GRANULAR MATERIAL, TYPE A (VARIABLE DEPTH)</li> <li>⑦ EXISTING AGGREGATE SHOULDER</li> <li>⑧ EXISTING BITUMINOUS SHOULDER</li> <li>⑨ EXISTING CONCRETE GUTTER, TYPE A OR TYPE B</li> <li>⑩ EXISTING CONCRETE CURB &amp; GUTTER, TYPE 5</li> <li>⑪ EXISTING CONCRETE CURB &amp; GUTTER, TYPE 7</li> <li>⑫ EXISTING CONCRETE MEDIAN</li> <li>⑬ PROPOSED HMA SURFACE REMOVAL (VARIABLE DEPTH)</li> </ul> | <ul style="list-style-type: none"> <li>⑬A PROPOSED HMA SURFACE REMOVAL, 2.25"</li> <li>⑭ PROPOSED HMA SURFACE COURSE, MIX. C N50 1.5"</li> <li>⑭A PROPOSED HMA SURFACE COURSE, MIX. D N70 1.5"</li> <li>⑮ PROPOSED LEVELING BINDER (MACHINE METHOD), IL-9.5 N50 0.75"</li> <li>⑮A PROPOSED LEVELING BINDER (MACHINE METHOD), IL-9.5 N70 0.75"</li> <li>⑯ PROPOSED HMA SHOULDERS, 6.5"</li> <li>⑰ PROPOSED AGGREGATE SHOULDER, TYPE B</li> <li>⑱ PROPOSED PAVED SHOULDER REMOVAL</li> <li>⑲ PROPOSED EXCAVATING AND GRADING SHOULDER</li> </ul> |
|--|--|

FILE NAME =	USER NAME = laughlinc1	DESIGNED -	REVISED -
et:\pwork\pwork\laughlinc1\0216293\0672065-shit-typical.dgn		DRAWN -	REVISED -
	PLOT SCALE = 40.0000' / in.	CHECKED -	REVISED -
	PLOT DATE = Feb-08-2011 11:29:07AM	DATE -	REVISED -

**STATE OF ILLINOIS  
 DEPARTMENT OF TRANSPORTATION**

**TYPICAL SECTIONS  
 ILLINOIS 29**

SCALE: SHEET NO. OF SHEETS STA. TO STA.

F.A.P. RTE.	SECTION	COUNTY	TOTAL SHEETS	SHEET NO.
658	(O)RS-1, (C,D,E)RS-3	MENARD	53	14
			CONTRACT NO. 72D65	
ILLINOIS FED. AID PROJECT				