

**ELEVATION AT PIER 5**

**TYPE II TFE ELASTOMERIC EXP. BRG.**

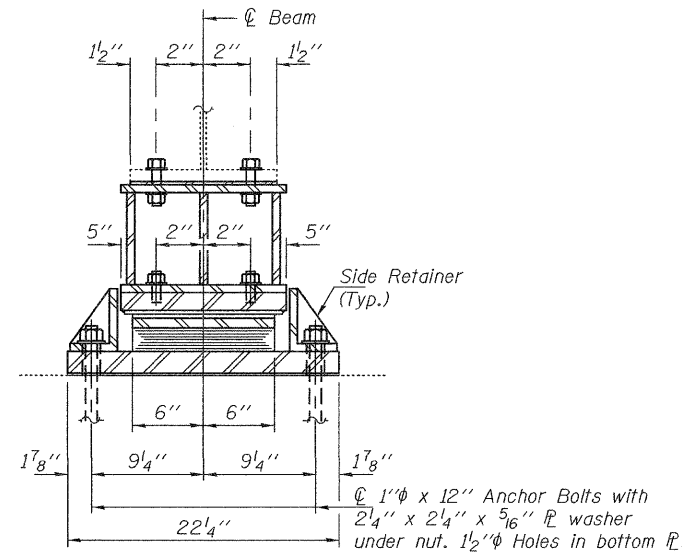

**SECTION A-A**

**BEAM REACTIONS**

	Unit I	Unit II
RP (K)	16.5	16.8
Rt (K)	31.3	31.2
Imp. (K)	9.4	9.4
R (Total) (K)	57.2	57.4

Notes:  
 Diaphragm removal and reinstallation may be required to facilitate drilling holes. Cost included with Furnishing and Erecting Structural Steel.  
 New steel extensions, shim plates and connection bolts are included with Furnishing and Erecting Structural Steel.  
 Prior to ordering any material, the Contractor shall verify in the field all bearing height and shim thickness dimensions. Min. jack capacity = 40 Tons.  
 Anchor bolts shall be ASTM F1554 all-thread (or an Engineer-approved alternate material) of the grade(s) and diameter(s) specified. ASTM A307 Grade C anchor bolts may be used in lieu of ASTM F1554 Grade 36 (Fy=36ksi). The corresponding specified grade of AASHTO M314 anchor bolts may be used in lieu of ASTM F1554.  
 Anchor bolts for Type II bearings shall be placed in holes drilled through the bottom bearing plate after members are in place. Side retainers shall be placed after bolts are installed.  
 Drilled and set anchor bolts shall be installed according to Article 521.06 of the Standard Specifications.  
 Side retainers shall be included in the cost of Elastomeric Bearing Assembly, Type II.  
 The 1/8" PTFE sheet shall be bonded directly to the top steel plate with a two-component, medium viscosity epoxy resin, conforming to the requirements of the Federal Specification MMM-A-134, Type I. The bond agent shall be applied on the full area of the contact surfaces.  
 Bonding of 1/8" PTFE sheet during vulcanizing process will be permitted provided the process and method of adjusting assembly height is approved by the Engineer.

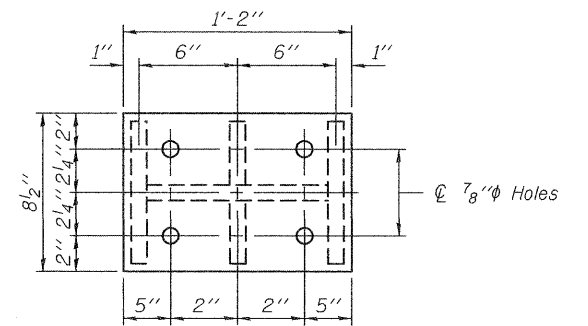

**PLAN TOP AND BOTTOM PLATE**

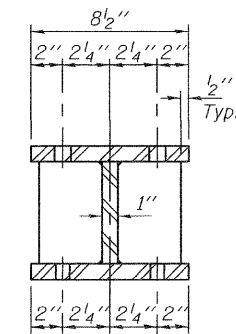

**SECTION B-B**

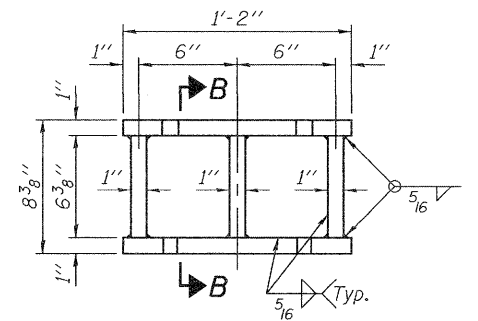

**STEEL EXTENSION DETAIL**

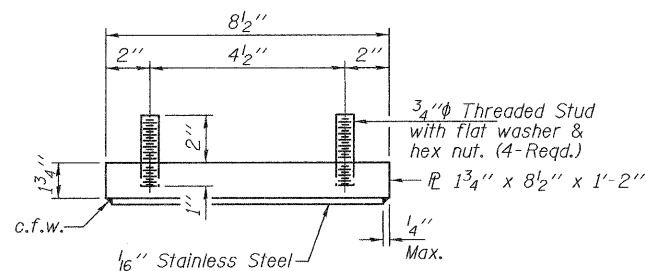

**TOP BEARING ASSEMBLY**

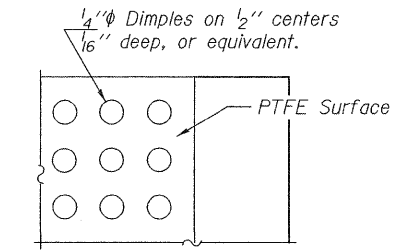

**PLAN-PTFE SURFACE**

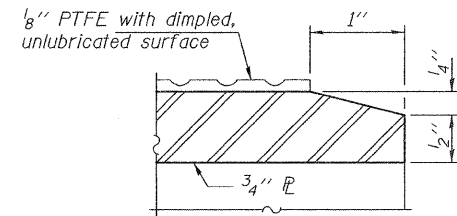

**SECTION THRU PTFE**

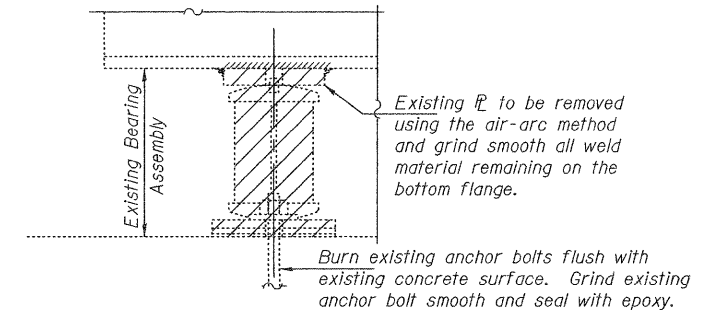

**EXISTING BEARING REMOVAL DETAIL**

Cost included with Jack and Remove Existing Bearings.

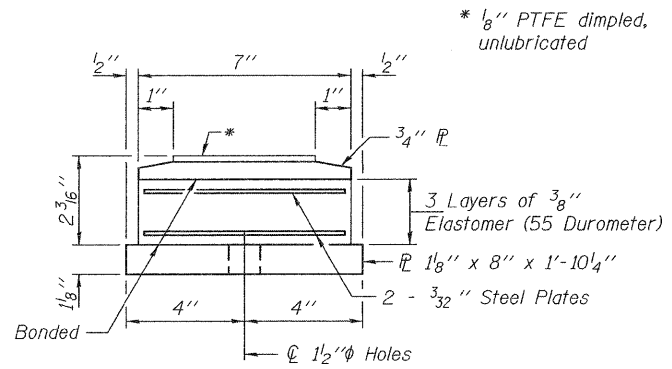

**BOTTOM BEARING ASSEMBLY**

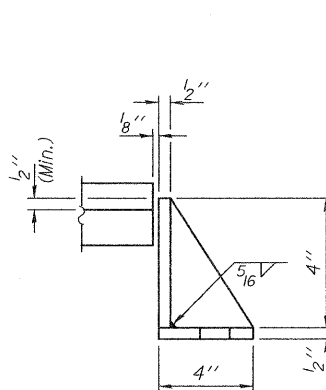

**SIDE RETAINER**

Equivalent rolled angle with stiffeners will be allowed in lieu of welded plates.

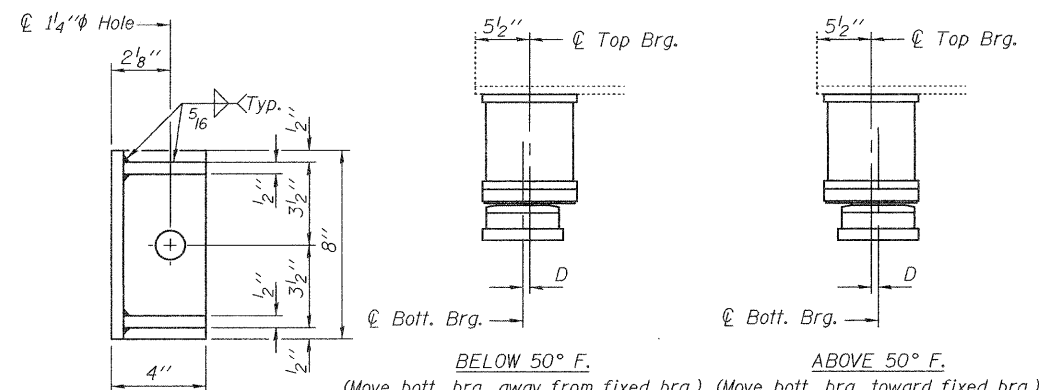

**SETTING ANCHOR BOLTS AT EXP. BRG.**

D = 1/8" per each 100' of expansion for every 15° temp. change from the normal temp. of 50°F.

**BILL OF MATERIAL  
TWO BEARING LINES**

Item	Unit	Total
Elastomeric Bearing Assembly, Type II	Each	12
Jack and Remove Existing Bearings	Each	12
Furnishing and Erecting Structural Steel	Pound	1540
Anchor Bolts 1"φ	Each	24

TYII/REPS 12-03-2008

DESIGNED IJL	EXAMINED
CHECKED DAB	PASSED
DRAWN baliva	
CHECKED IJL DAB	

 ACTING ENGINEER OF STRUCTURAL SERVICES	DATE - MARCH 7, 2011
 ACTING ENGINEER OF BRIDGES AND STRUCTURES	

**STATE OF ILLINOIS  
DEPARTMENT OF TRANSPORTATION**

**PIER 5 BEARING REPLACEMENT DETAILS  
SN 096-0062**

SHEET NO. 3 OF 3 SHEETS

F.A. RTE.	SECTION	COUNTY	TOTAL SHEETS	SHEET NO.
821	DT BRIDGE REPAIRS 2011-1	WAYNE	23	17
CONTRACT NO. 74485				
ILLINOIS FED. AID PROJECT				