

SECTION M-M
Splice PL's not shown for clarity

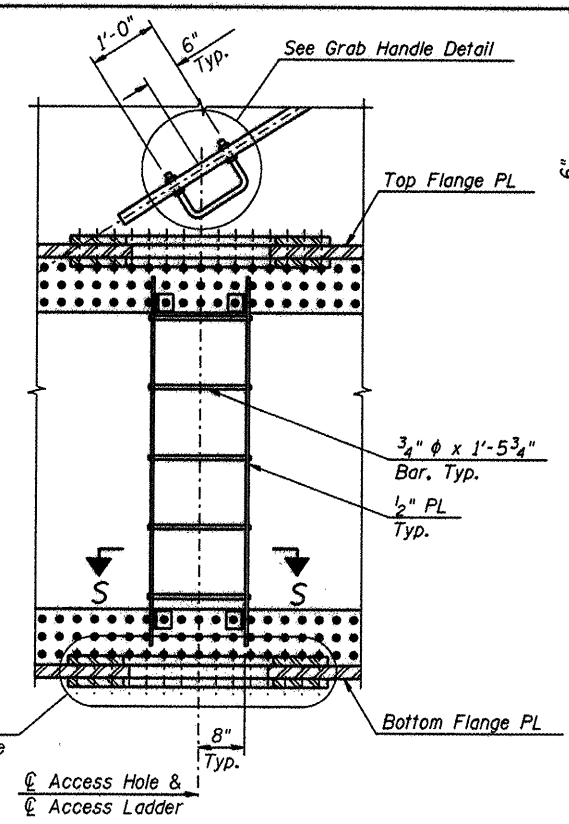

SECTION N-N

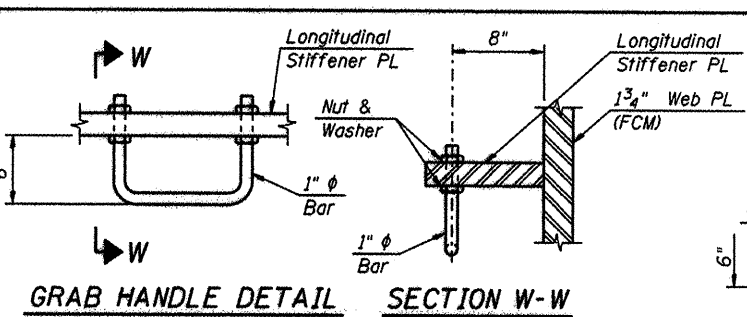

GRAB HANDLE DETAIL SECTION W-W

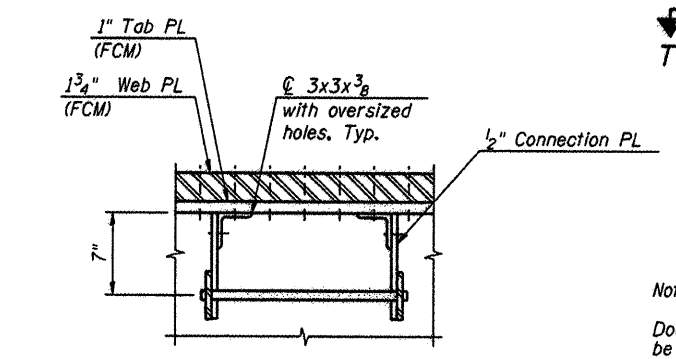

SECTION S-S

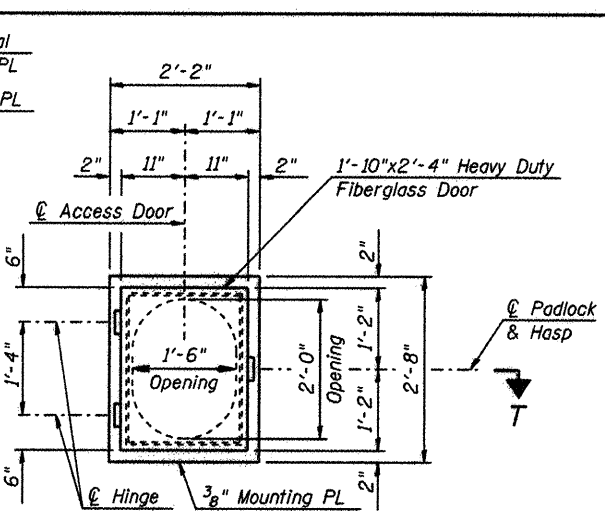

ACCESS DOOR DETAIL

Detail for West End Joints TO Only.
No external access hole in East End Joints T11.

Notes:
Install fiberglass door per manufacturer's recommendations. Door shall be heavy duty and water tight. Fiberglass door shall be approved by the Engineer.

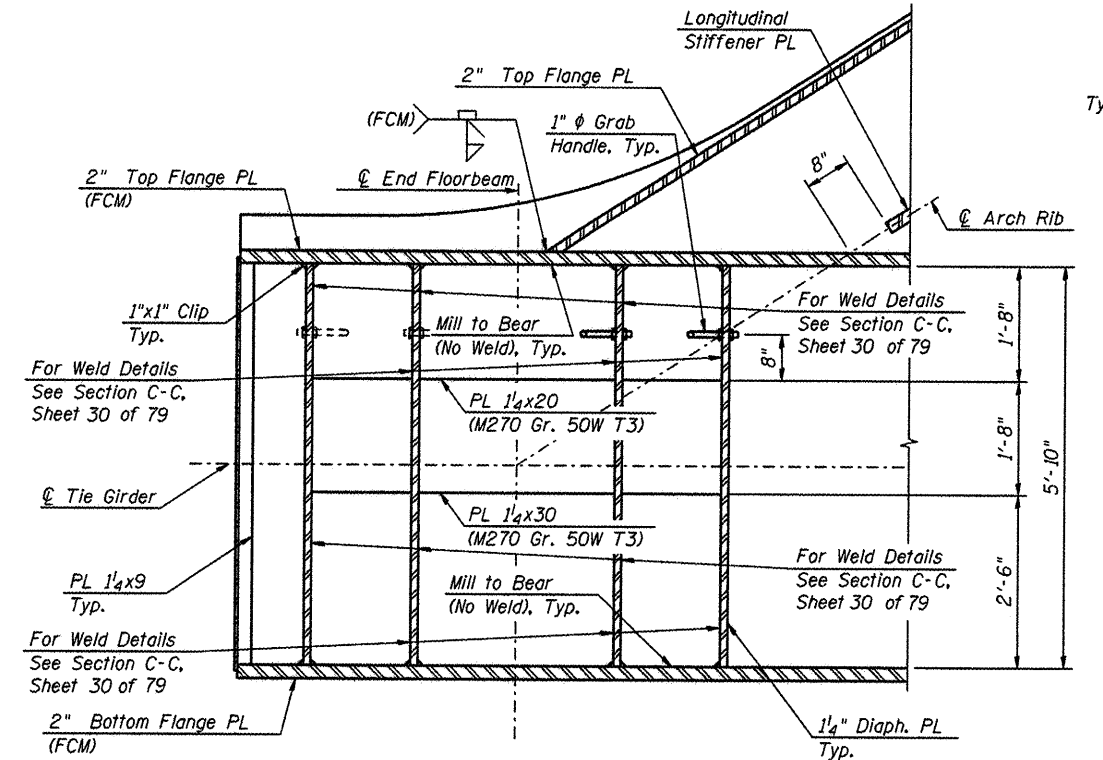

SECTION Q-Q

Tab PL's, Connection PL's and Web Bolts not shown for clarity

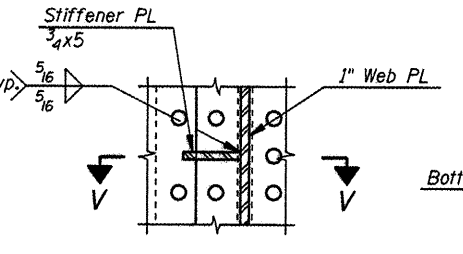

DETAIL R

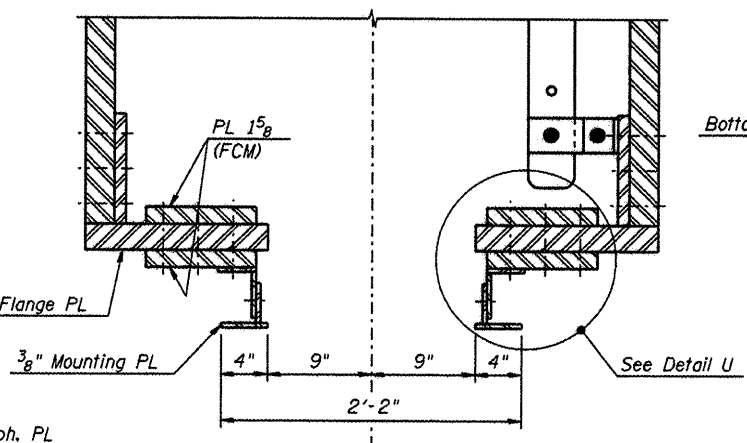

SECTION T-T

Fiberglass Door not shown for clarity
Section at West End Joints TO only.
No access hole in bottom flange at East End Joints T11.

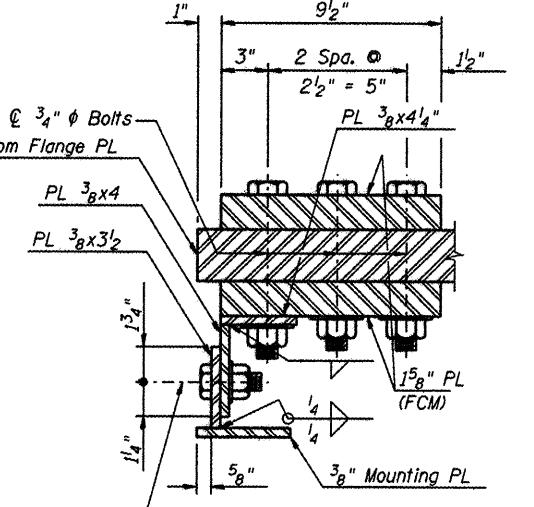

DETAIL U

Detail at West End Joints TO only.
No access hole in bottom flange at East End Joints T11.

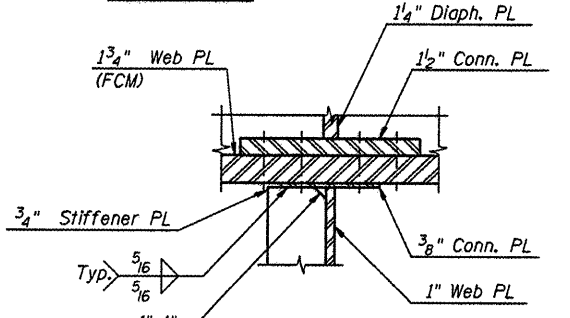

SECTION V-V

Splice PL's not shown for clarity

EXTERNAL ACCESS HOLE NOTE:
External Access Hole and additional flange plates are to be installed at TO only (West End Joints only). No hole shall be provided in East End Joint Bottom Flange Plates T11.

Notes:
• Denotes 7/8 inch diameter high-strength bolt.
○ Denotes 1 inch diameter high-strength bolt.
For Floorbeam Connection, see Sheet 54 and 55 of 79.
For additional notes and details, see Sheets 30, 31 and 32 of 79.
For location of Section M-M, see Sheet 30 of 79.
For location of Section N-N, see Sheet 31 of 79.
For location of Section Q-Q, see Sheet 32 of 79.

L:\PROJECTS\001\085529\00-1\CADD\Sheets\53_Tied Arch End Details 2.dgn

CMT
CRAWFORD, MURPHY & TULLY, INC.
CONSULTING ENGINEERS
LICENSE NO. 084-000613

HNTB

DESIGNED - PA, JDJ, BPD, CJW	REVISED -
DRAWN - GLD	REVISED -
CHECKED - RJK	REVISED -
DATE - 02/04/2011	REVISED -

**CITY OF ROCKFORD
MORGAN STREET BRIDGE**

**TIED ARCH END DETAILS - III
STRUCTURE NO. 101-6108**

SCALE: SHEET NO. 33 OF 79 SHEETS STA. 47+00.74 TO STA. 52+63.50

F.A.I. RTE.	SECTION	COUNTY	TOTAL SHEETS	SHEET NO.
5077	99-00493-00-BR	WINNEBAGO	253	159
CONTRACT NO. 85529			FED. ROAD DIST. NO. 2 ILLINOIS FED. AID PROJECT BRN-5095653	