

* Cut bottom end of post to curb slope.

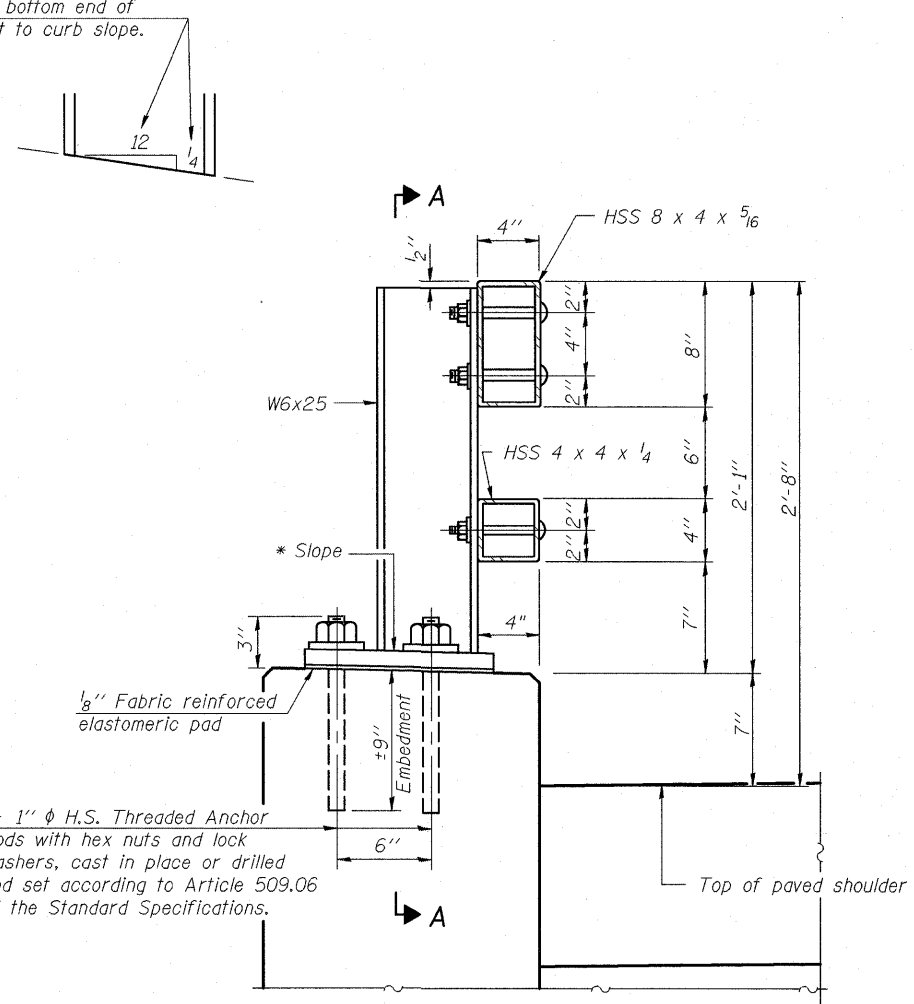

SECTION AT RAIL POST

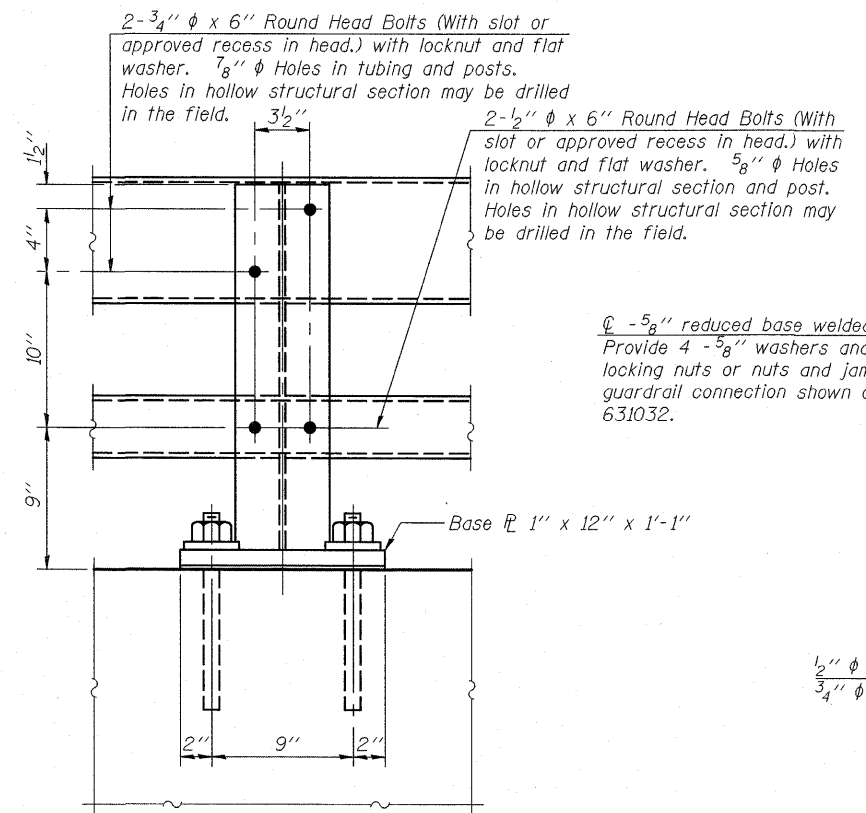

SECTION A-A

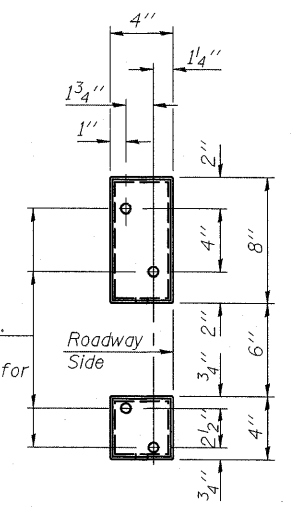

VIEW B-B

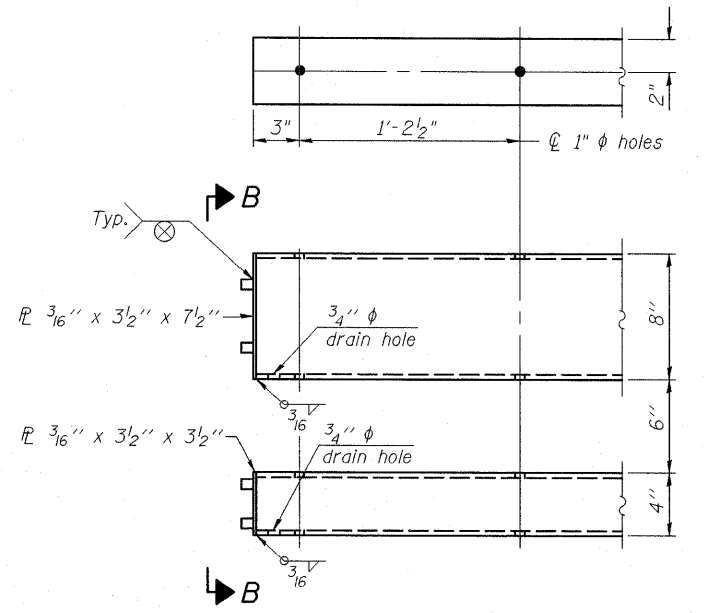

END OF RAIL DETAILS

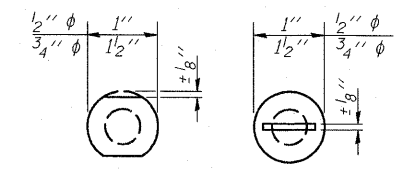

VIEW C-C

Notes:
 All field drilled holes shall be coated with an approved zinc rich paint before erection.
 Posts shall not be located closer than 1'-3" to an existing bridge expansion joint or end of bridge.
 Steel Bridge Rail expansion joint shall be provided between any two (2) posts which span a bridge expansion joint. Bolts located at expansion joint shall be provided with locknuts and shall be tightened only to a point that will allow railing movement.
 Provide one 1/8" and two 1/16" steel shims for 25% of the posts. Shims shall be similar to base plates in size and holes.
 All steel rail elements shall be galvanized according to Article 509.05 of the Standard Specifications.

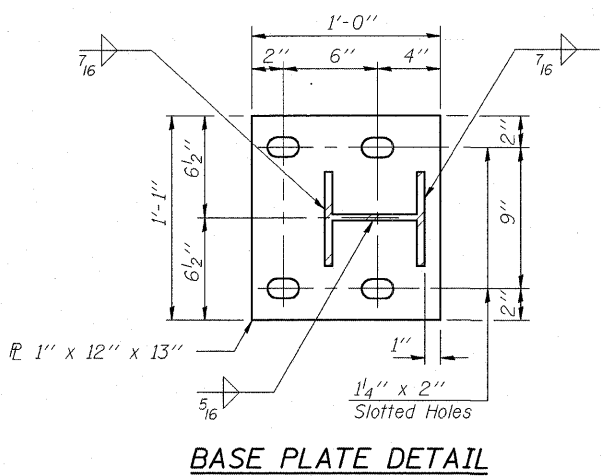

BASE PLATE DETAIL

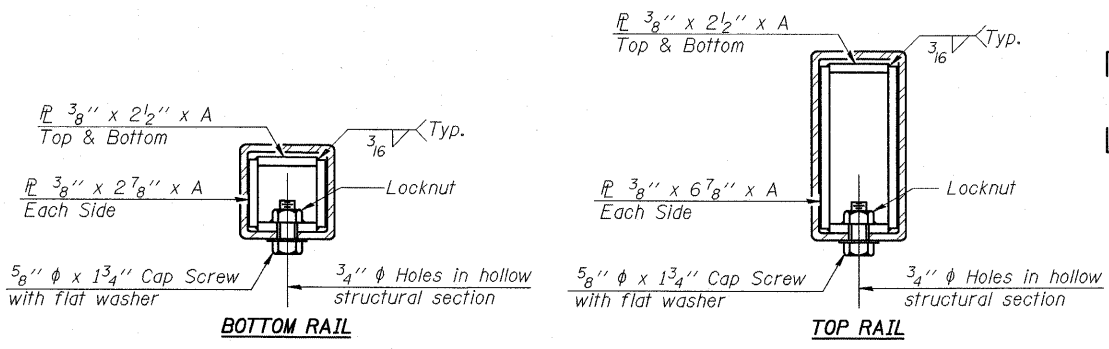

SECTIONS AT RAIL SPLICE

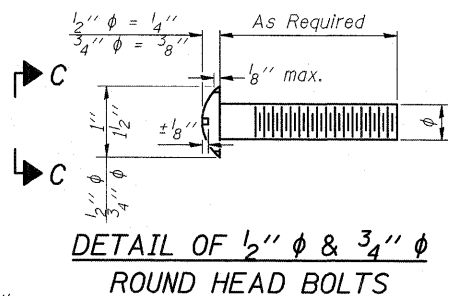

DETAIL OF 1/2" & 3/4" ROUND HEAD BOLTS

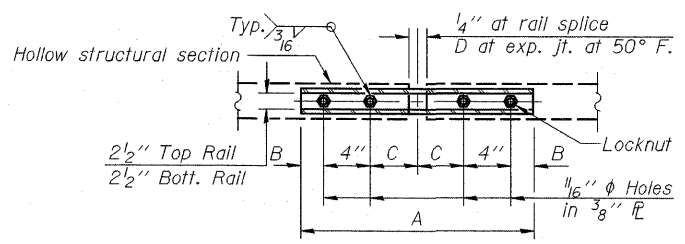

PLAN-BOTT. SPLICE TYPICAL

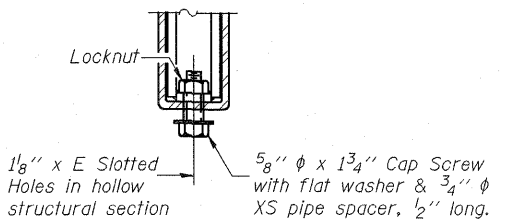

RAIL SPLICE CONNECTION AT EXPANSION JT.

SPLICE DIMENSIONS

T	D	A	B	C	E
≤ 4"	2 1/2"	1'-8"	2"	4"	2 1/2"
> 4" ≤ 6 1/2"	3 3/4"	2'-0"	2 1/2"	5 1/2"	3 1/2"
> 6 1/2" ≤ 9"	5"	2'-4"	3 1/2"	6 1/2"	9"
> 9" ≤ 13"	7"	2'-10"	4 1/2"	8 1/2"	11"
Rail Splice	1/4"	1'-8"	2"	4"	—

T = Total movement at expansion joint as shown on the design plans.

BILL OF MATERIAL

Item	Unit	Quantity
Steel Railing, Type 2399	Foot	44