

EXISTING TYPICAL SECTION
ILLINOIS RTE. 59
FROM STA. 32+68 TO STA. 34+00

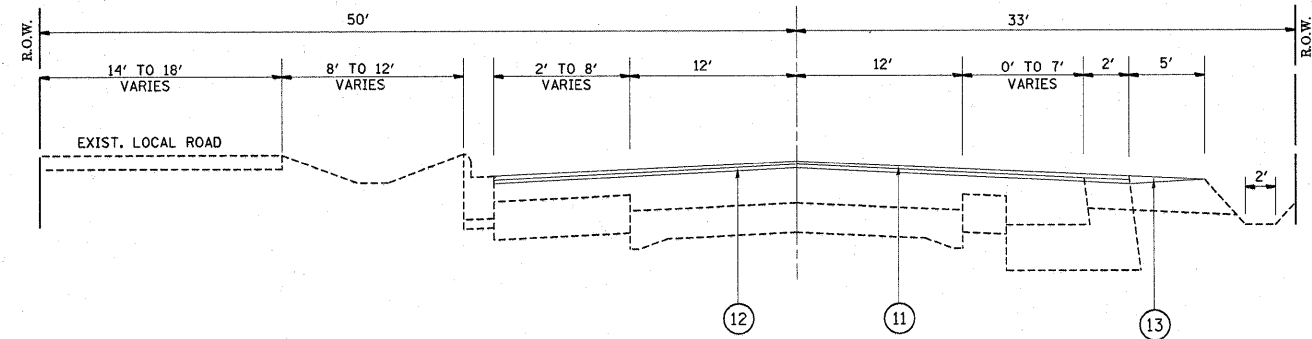

PROPOSED TYPICAL SECTION
ILLINOIS RTE. 59
FROM STA. 32+68 TO STA. 34+00

LEGEND

- ① EXIST. HMA SURFACE COURSE 2-1/2"
- ② EXIST. HMA PAVEMENT 3-1/2"
- ③ EXIST. HMA BASE COURSE WIDENING 9"
- ④ EXIST. P.C. CONCRETE PAVEMENT 9"
- ⑤ EXIST. COMB. CURB AND GUTTER, TY B-6.24
- ⑥ EXIST. AGGREGATE SHOULDER TY B
- ⑦ EXIST. HMA SHOULDER 8"
- ⑧ EXIST. AGGREGATE SUBGRADE
- ⑨ EXIST. SUBBASE GRANULAR MATERIAL
- ⑩ PROP. HMA SURFACE REMOVAL 2-1/4"
- ⑪ PROP. HMA SURFACE COURSE, MIX "D" N 70, 1-1/2"
- ⑫ PROP. POLYMERIZED LEVELING BINDER (MACHINE METHOD), IL-4.75, N 50, 3/4"
- ⑬ PROP. AGGREGATE WEDGE SHOULDER TYPE B

NOTE: CONTRACTOR SHALL MILL FIRST BEFORE PATCHING

HOT-MIX ASPHALT MIXTURE REQUIREMENT

MIXTURE TYPE	AIR VOIDS (%)
POLY. LEVELING BINDER (MACHINE METHOD), IL 4.75, N50	4% @ 50 GYR
HOT-MIX ASPHALT SURFACE COURSE, MIX "D", N70 (IL-9.5 mm)	4% @ 70 GYR
CLASS D PATCHES (HMA BINDER IL-19)	4% @ 70 GYR

NOTE: THE UNIT WEIGHT USED TO CALCULATE ALL HOT-MIX ASPHALT SURFACE MIXTURE IS 112 LBS/SQ. YD./IN.

THE "AC TYPE" FOR POLYMERIZED HMA MIXES SHALL BE "SBS/SBR PG 70-22" AND FOR NON-POLYMERIZED HMA "AC TYPE" SHALL BE "PG 64-22" UNLESS MODIFIED BY DISTRICT ONE SPECIAL PROVISIONS.

FOR "PERCENT OF RAP" SEE DISTRICT ONE SPECIAL PROVISIONS

FILE NAME =	USER NAME = byunsh	DESIGNED -	REVISED -	STATE OF ILLINOIS DEPARTMENT OF TRANSPORTATION	ILLINOIS ROUTE 59 EXISTING AND PROPOSED TYPICAL SECTIONS		F.A.P. RTE. 104	SECTION 106 RS-5	COUNTY LAKE	TOTAL SHEETS 31	SHEET NO. 4	
es:\pwork\pwork\byunsh\0180500\0124110-sh-t-plan.dgn	DRAWN -	REVISED -	REVISED -		SCALE:	SHEET NO. OF SHEETS	STA. TO STA.	ILLINOIS FED. AID PROJECT				
	PLOT SCALE = 50,0000 ' / IN.	CHECKED -	REVISED -									
	PLOT DATE = 3/17/2010	DATE -	REVISED -									