

CENTRAL AVENUE

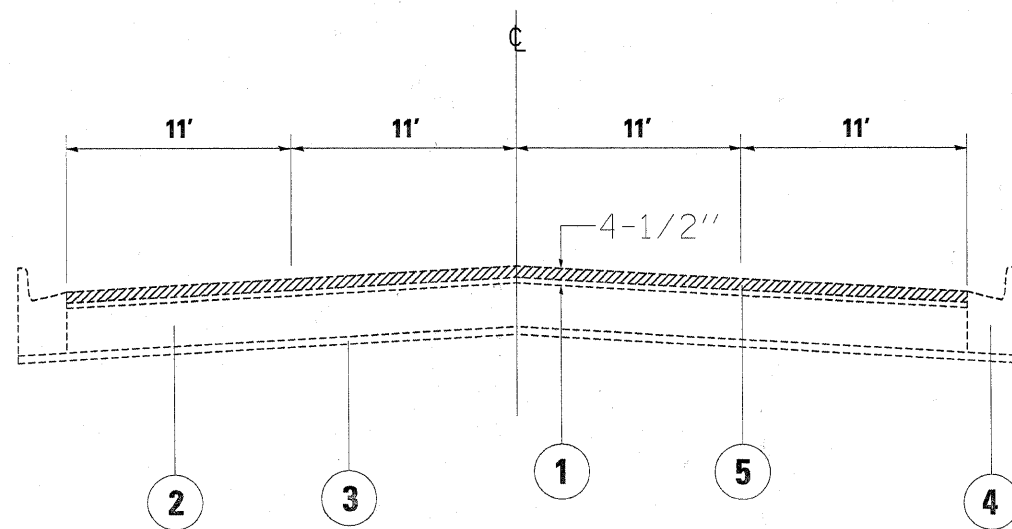

EXISTING TYPICAL CROSS SECTION  
 STA. 10+00 TO STA. 54+00  
 STA. 74+00 TO STA. 83+00

LEGEND

- ① EXISTING HOT-MIX ASPHALT OVERLAY, 4-1/2"
- ② EXISTING PORTLAND CEMENT CONCRETE, 9"
- ③ EXISTING SUB-BASE GRANULAR MATERIAL, TYPE A, 4"
- ④ EXISTING CONCRETE CURB AND GUTTER, TYPE B-6.12
- ⑤ PROP. HOT-MIX ASPHALT SURFACE REMOVAL, 2-1/2"
- ⑥ PROP. POLYMERIZED HOT-MIX ASPHALT SURFACE COURSE, MIX "F", N90, 1-3/4"
- ⑦ PROP. POLYMERIZED LEVELING BINDER (MACHINE METHOD), IL-4.75, N50, 3/4"

NOTE: CONTRACTOR IS TO MILL ROADWAY BEFORE PATCHING

CENTRAL AVENUE

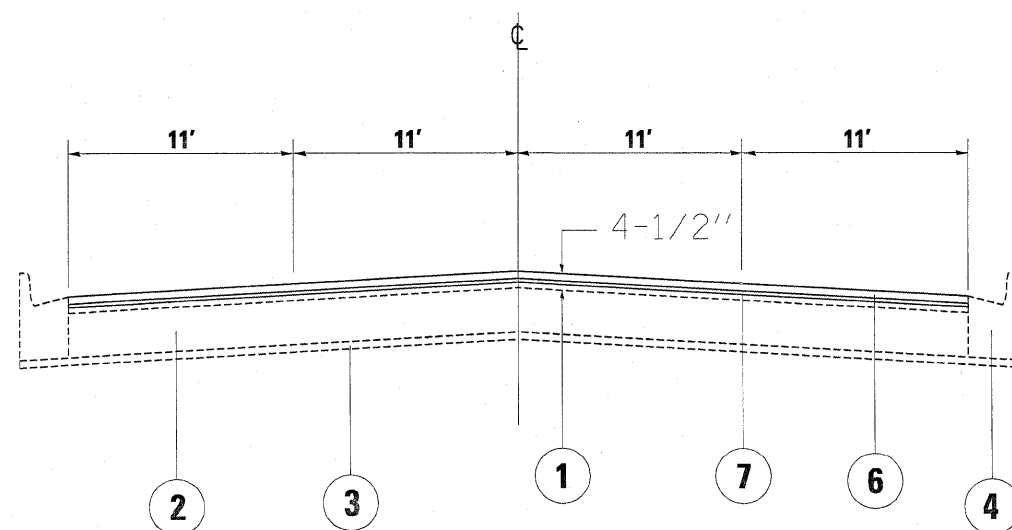

PROPOSED TYPICAL CROSS SECTION  
 STA. 10+00 TO STA. 54+00  
 STA. 74+00 TO STA. 83+00

FILE NAME =	USER NAME = byunsh	DESIGNED -	REVISED -	<b>STATE OF ILLINOIS DEPARTMENT OF TRANSPORTATION</b>	<b>CENTRAL AVENUE 47TH STREET TO 63RD STREET EXISTING AND PROPOSED TYPICAL SECTIONS</b>	F.A.P. RTE.	SECTION	COUNTY	TOTAL SHEETS	SHEET NO.	
c:\pwwork\pwwork\byunsh\d0180187\0132110	sh-t-plendgn	DRAWN -	REVISED -			366	0203 RS-2	COOK	23	5	
	PLOT SCALE = 50.0000' / IN.	CHECKED -	REVISED -			CONTRACT NO. 60J99					
	PLOT DATE = 2/9/2010	DATE -	REVISED -			ILLINOIS FED. AID PROJECT					