

PLAN VIEW

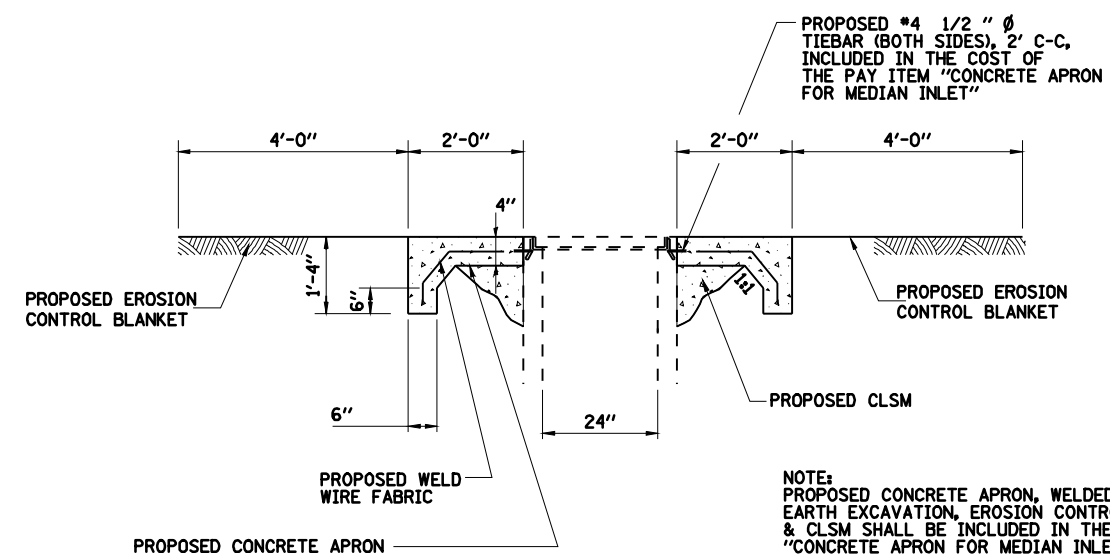

SECTION A-A  
CONCRETE APRON FOR MEDIAN INLET BOX (542546)

FILE NAME =	USER NAME = laughlinr1	DESIGNED -	REVISED -
er:\pwork\pwidot\LAUGHLINRL\0182983\093-shit-Details.dgn		DRAWN -	REVISED -
PLOT SCALE = 100.0000' / IN.		CHECKED -	REVISED -
PLOT DATE = Feb-01-2010 10:55:05AM		DATE -	REVISED -

STATE OF ILLINOIS  
DEPARTMENT OF TRANSPORTATION

CONCRETE APRON FOR MEDIAN INLET BOX (542546) DETAIL  
SCALE: none SHEET NO. 6 OF 9 SHEETS STA. TO STA.

F.A.I. RTE.	SECTION	COUNTY	TOTAL SHEETS	SHEET NO.
172	1-(1,2,3,4,5)RS	ADAMS	165	98
CONTRACT NO. 72A09				
FED. ROAD DIST. NO. ILLINOIS FED. AID PROJECT				