

TYPICAL #3
RAMP (TANGENT)
FAU 8136 (STAUNTON ROAD) INTERCHANGE

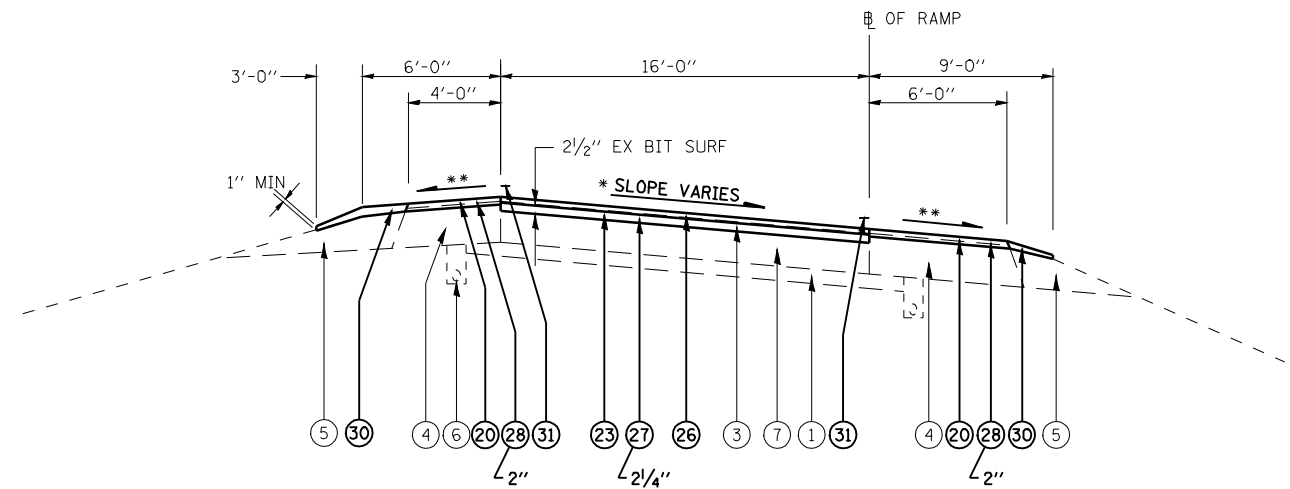

TYPICAL #4
RAMP (SUPERELEVATED)
FAU 8136 (STAUNTON ROAD) INTERCHANGE

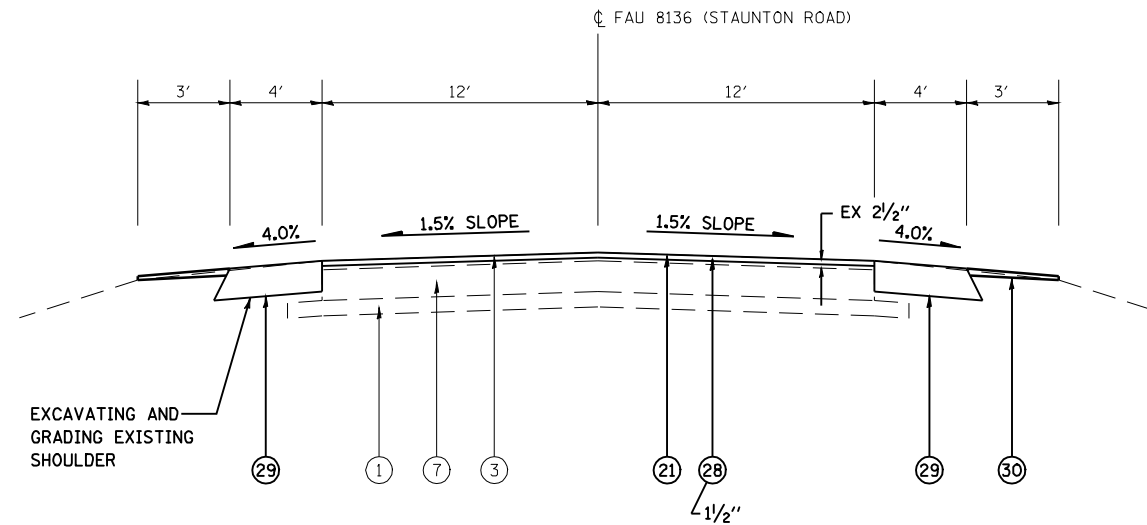

TYPICAL #5
FAU 8136 (STAUNTON ROAD)
STA 105+66.00 TO STA 106+57.83
STA 119+04.40 TO STA 122+25.00
STA EQ 122+25.00 BK = STA 21+09.83 AH
STA 21+09.83 TO STA 22+12.78

* MATCH EXISTING CROSS SLOPES AT TRANSITIONS AND SUPER ELEVATED SECTIONS

** WHEN THE SUPERELEVATION RATE OF PAVEMENT IS BETWEEN 0.0% AND 4.0%, THE SHOULDER SLOPE SHALL BE SLOPED AT 4.0%. WHEN THE SUPER ELEVATION RATE OF PAVEMENT EXCEEDS 4.0%, THE SHOULDER SHALL BE SLOPED SO THAT THE ALGEBRAIC DIFFERENCE BETWEEN THE PAVEMENT AND SHOULDER IS 8.0% FOR THE HIGH SIDE OF THE SE, AND MATCH THE SE FOR THE LOW SIDE OF THE SE.

*** HMA SURFACE REMOVAL SHALL BE THE DEPTH SPECIFIED AT THE EOP, AND MAY VARY DUE TO EXISTING SHOULDER SLOPE

EXISTING LEGEND

- ① EX STABILIZED SUB-BASE 4"
- ② EX CRPCC PAVEMENT 9"
- ③ EX HOT-MIX ASPHALT SURFACE COURSE (THICKNESS VARIES)
- ④ EX HMA SHOULDERS (THICKNESS VARIES)
- ⑤ EX AGGREGATE SHOULDERS
- ⑥ EX PIPE UNDERDRAINS 6"
- ⑦ EX PCC PAVEMENT 8"
- ⑧ EX COMBINATION CONCRETE CURB & GUTTER M-6.06
- ⑨ EX PCC MEDIAN SURFACE 4"

PROPOSED LEGEND

- ⑳ PR HOT-MIX ASPHALT SURFACE REMOVAL, 3/4"
- ㉑ PR HOT-MIX ASPHALT SURFACE REMOVAL, 1 1/2"
- ㉒ PR HOT-MIX ASPHALT SURFACE REMOVAL, 2"
- ㉓ PR HOT-MIX ASPHALT SURFACE REMOVAL, 2 1/2"
- ㉔ PR HOT-MIX ASPHALT SURFACE REMOVAL, 3 1/4"
- ㉕ PR HOT-MIX ASPHALT SURFACE REMOVAL, 5"
- ㉖ PR POLYMERIZED HMA SURFACE COURSE, MIX "E", N105 1 1/2"
- ㉗ PR POLYMERIZED HMA BINDER COURSE, IL-19.0, N105
- ㉘ PR POLYMERIZED HMA SURFACE COURSE, MIX "C", N50
- ㉙ PR HMA SHOULDER 8"
- ㉚ PR AGGREGATE SHOULDERS, TYPE B (WEDGE)
- ㉛ PR PAVEMENT MARKING

FILE NAME =	USER NAME = coxte	DESIGNED -	REVISED -
es:\pwwork\pwidot\COXTE\dma25312\0672400-Types01.s.dgn		DRAWN -	REVISED -
		CHECKED -	REVISED -
		DATE -	REVISED -

STATE OF ILLINOIS
DEPARTMENT OF TRANSPORTATION

TYPICAL SECTIONS
FAU 8136 (STAUNTON RD)

SCALE: NONE SHEET NO. OF SHEETS STA. TO STA.

F.A.I. RTE.	SECTION	COUNTY	TOTAL SHEETS	SHEET NO.
55	59RS-2, BR	MACOUPIN	100	12
			CONTRACT NO. 72A60	
ILLINOIS FED. AID PROJECT				