

* Granular or solid Flux filled headed studs conforming to Article 1006.32 of the Std. Specs., automatically end welded.

STATE OF ILLINOIS
DEPARTMENT OF TRANSPORTATION

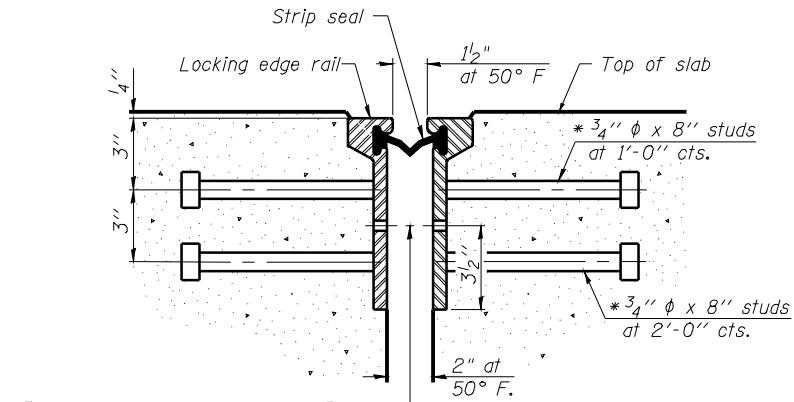

7/16" ϕ holes at 4'-0" cts. for 3/8" ϕ bolts. All bolts shall be burned, sawed, or chipped off flush with the plates after forms are removed, typ.

**SECTION THRU
ROLLED RAIL JOINT**

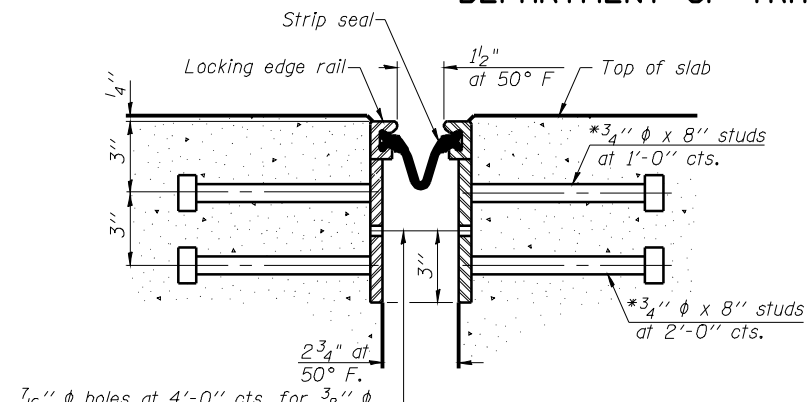

7/16" ϕ holes at 4'-0" cts. for 3/8" ϕ bolts. All bolts shall be burned, sawed, or chipped off flush with the plates after forms are removed, typ.

**SECTION THRU
WELDED RAIL JOINT**

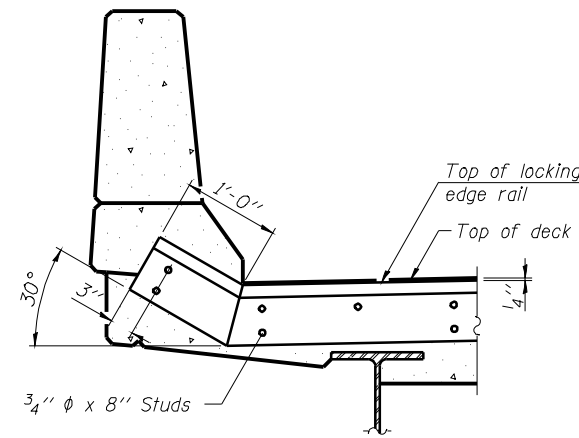

AT PARAPET
See Section A-A for end treatment of skews > 30°.

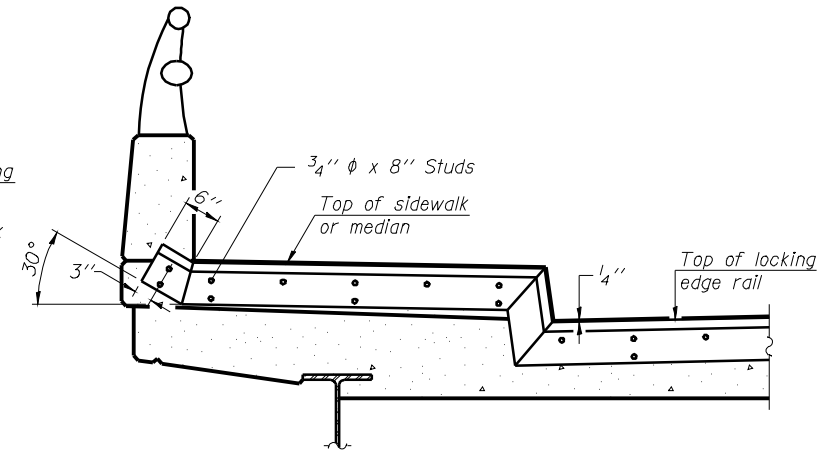

AT SIDEWALK OR MEDIAN
Shorter plates with a single row of studs at 12" cts. may be necessary on medians which are shallower than 9". See manufacturer's recommendation.

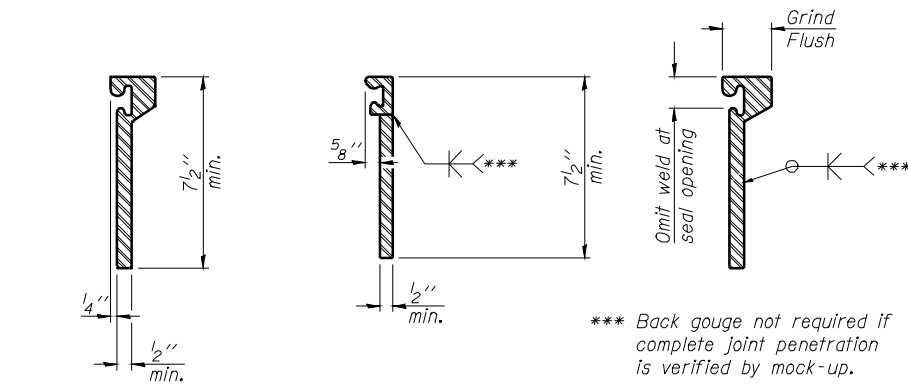

**ROLLLED
EXTRUDED RAIL**

WELDED RAIL

**LOCKING EDGE
RAIL SPLICE**
The inside of the locking edge rail groove shall be free of weld residue.
Rolled rail shown, welded rail similar.

LOCKING EDGE RAILS

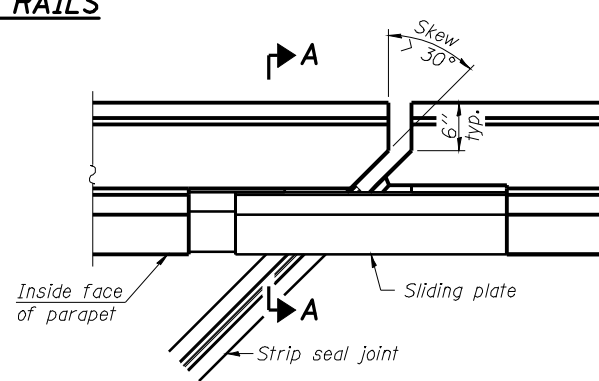

PLAN

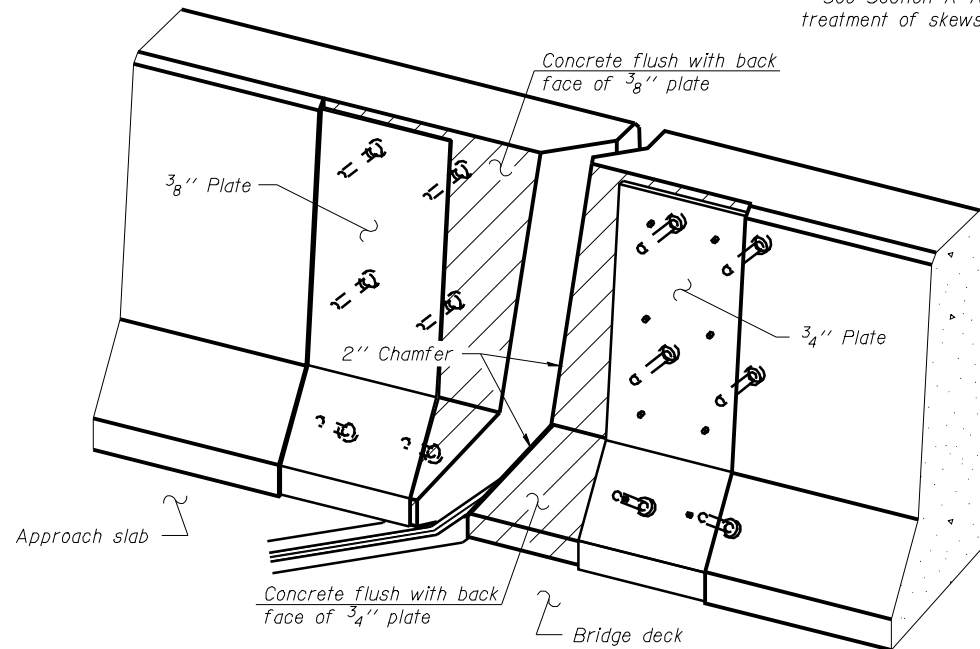

TYPICAL END TREATMENTS

Notes:
The strip seal shall be made continuous and shall have a minimum thickness of 1/4". The configuration of the strip seal shall match the configuration of the Locking Edge Rails. Open or "webbed" strip seal gland configurations are not permitted. The gland shall be sized for a maximum rated movement of 4 inches.
The Locking Edge Rails depicted are conceptual only, except for the minimum dimensions shown. The actual configuration of the Locking Edge Rails and matching strip seal may vary from manufacturer to manufacturer. Flanged edge rails will not be allowed. Locking Edge Rails may be spliced at slope discontinuities.
The manufacturer's recommended installation methods shall be followed.
The joint opening and deck dimensions detailed on the superstructure are based on a rolled rail expansion joint. If the Contractor elects to use the welded rail expansion joint, the opening and deck dimensions shall be modified according to the dimensions detailed on this sheet. Required modifications shall be made at no additional cost to the State.
All steel components shall be galvanized after fabrication according to Article 520.03 of the Standard Specifications.
Maximum space between rail segments at stage lines shall be 3/16", sealed with a suitable sealant.

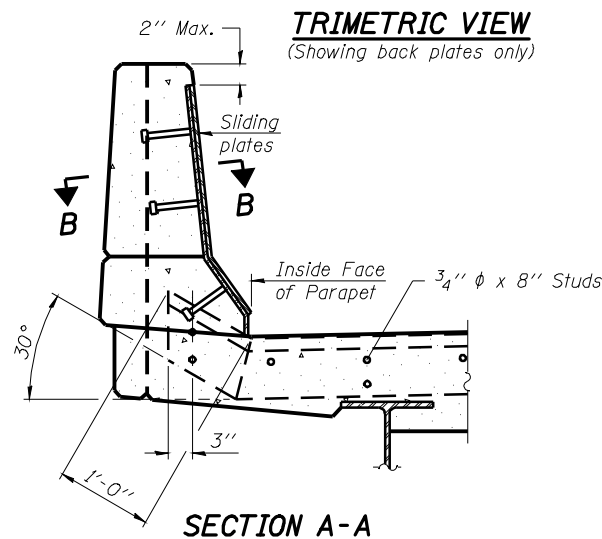

POINT BLOCK DETAILS
(for skews > 30°)

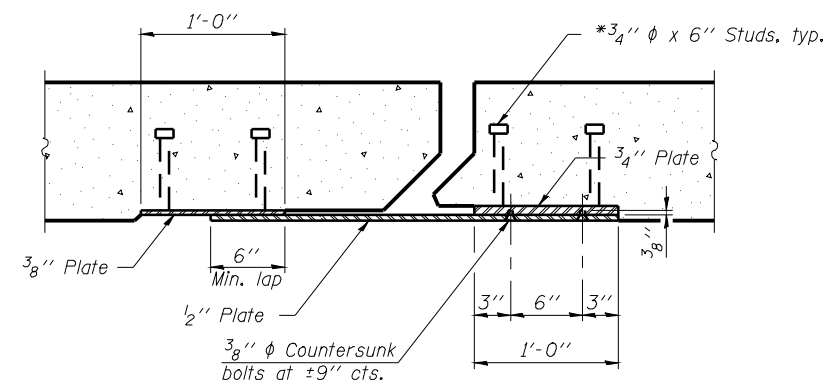

SECTION B-B

BILL OF MATERIAL

Item	Unit	Total
Preformed Joint Strip Seal	Foot	134.0

**PREFORMED JOINT STRIP SEAL
STRUCTURE NO. 059-0045**

SHEET NO. 5 10 SHEETS	F.A.I. RTE.	SECTION	COUNTY	TOTAL SHEETS	SHEET NO.
	55	59RS-2, BR	Macoupin	100	95
FED. ROAD DIST. NO.			ILLINOIS FED. AID PROJECT		
CONTRACT NO. 72A60					