

STATE OF ILLINOIS  
DEPARTMENT OF TRANSPORTATION

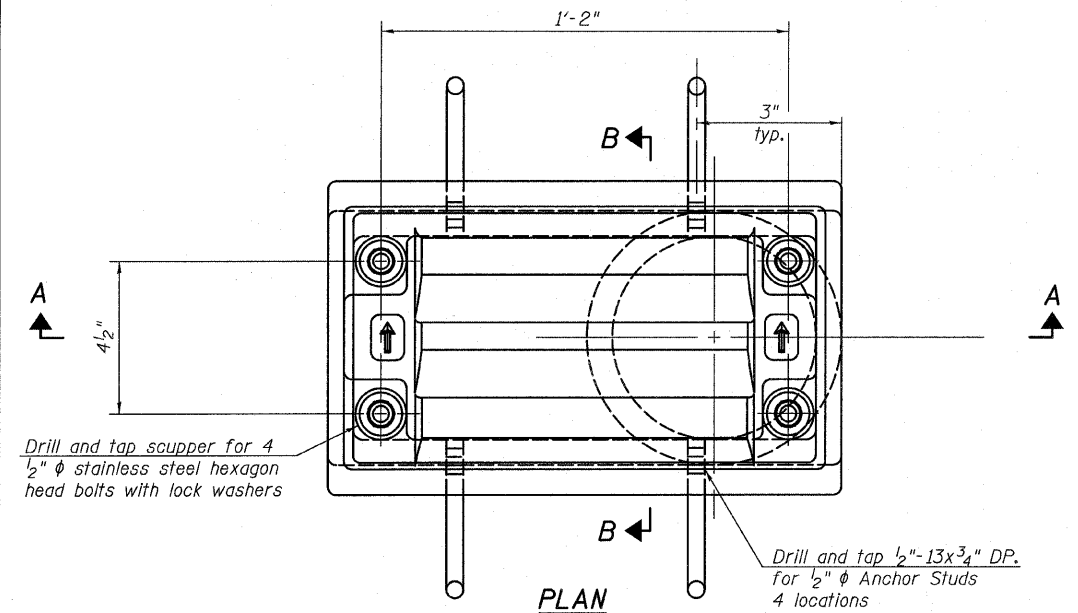

PLAN

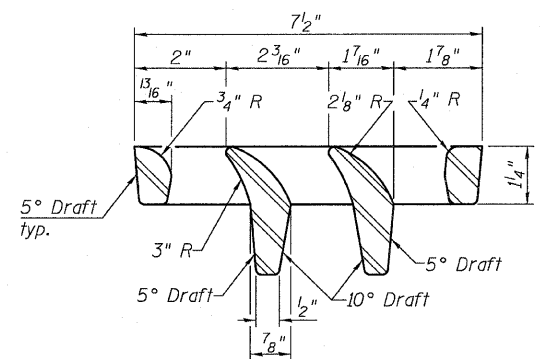

VANE GRATE DETAIL

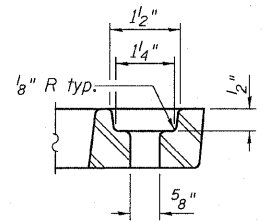

BOLT HOLE DETAIL

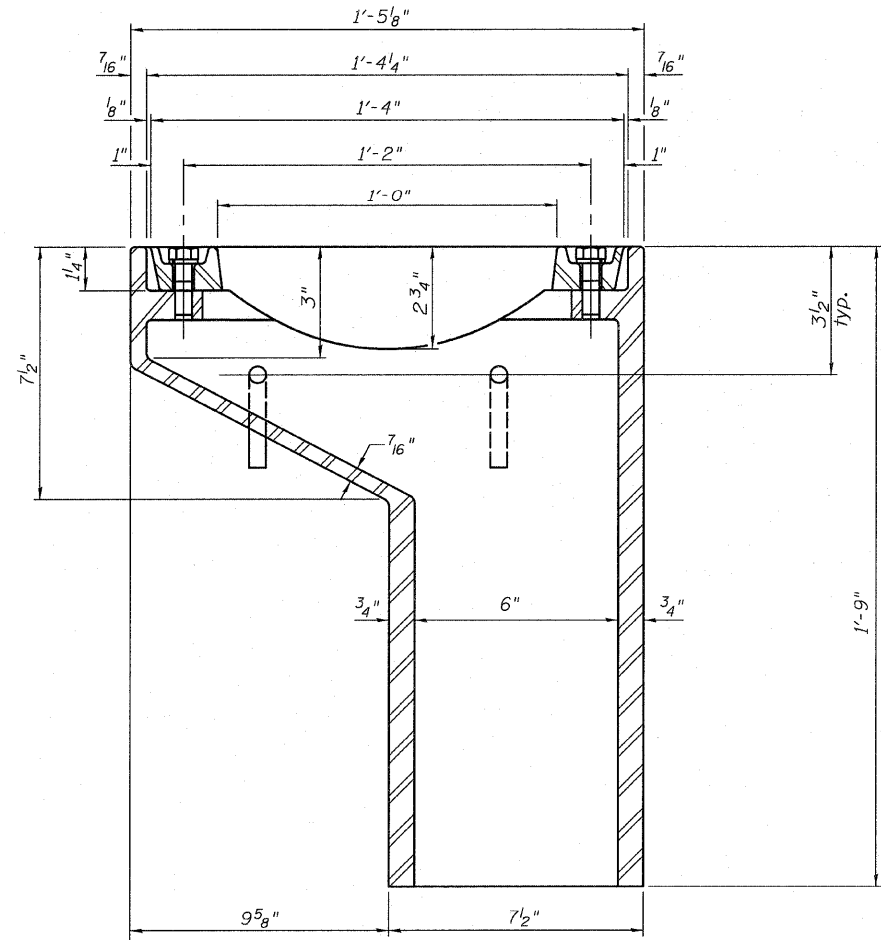

SECTION A-A

See sheet 13 of 38 for scupper location relative to parapet.

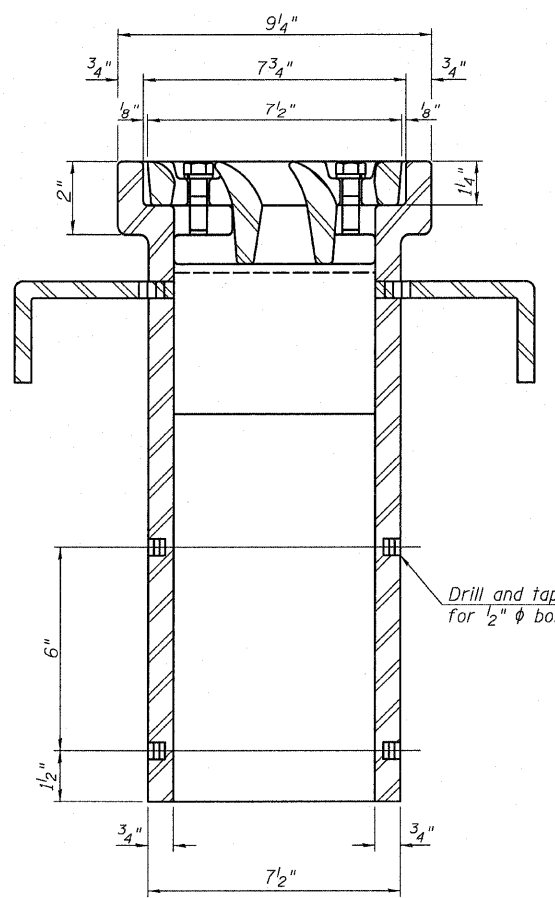

SECTION B-B

Drill and tap 1/2"-13x1/2" DP. for 1/2" φ bolts. (4 locations)

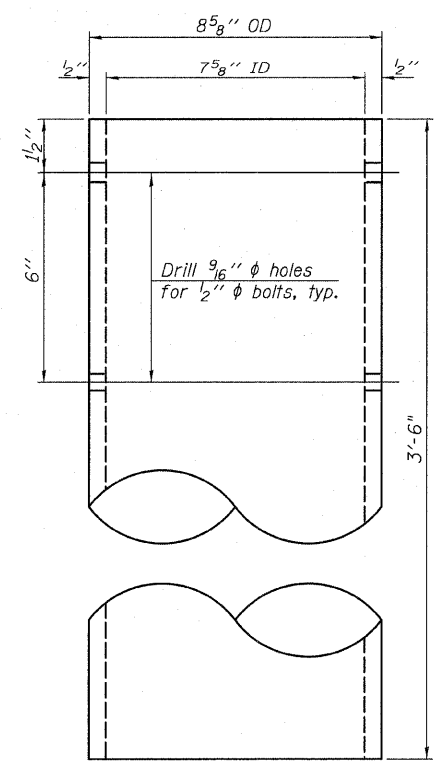

DOWNSPOUT

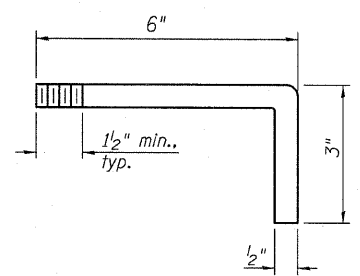

ANCHOR STUD DETAIL

BILL OF MATERIAL

Item	Unit	Quantity
Drainage Scuppers, DS-11	Each	4

DRAINAGE SCUPPERS, DS-11  
STRUCTURE NO. 026-0105

SHEET NO. 17 38 SHEETS	F.A.P. RTE. 752	SECTION (U-2BR)B-1	COUNTY FAYETTE	TOTAL SHEETS 71	SHEET NO. 39
	FED. ROAD DIST. NO. 7 ILLINOIS FED. AID PROJECT			CONTRACT NO. 74235	



Eastport Business Center 1  
100 Lanter Court, Suite 1  
Collinsville, Illinois 62234  
618-345-2200  
Design Firm License No. 184.001115

DESIGNED -  
CHECKED -  
DRAWN -  
CHECKED -