

PLAN - PIER 13

Note: This drawing is not to scale. Follow dimensions.

Detailed JUL 2009
Checked JUL 2009

Sheet No. 122 of 152

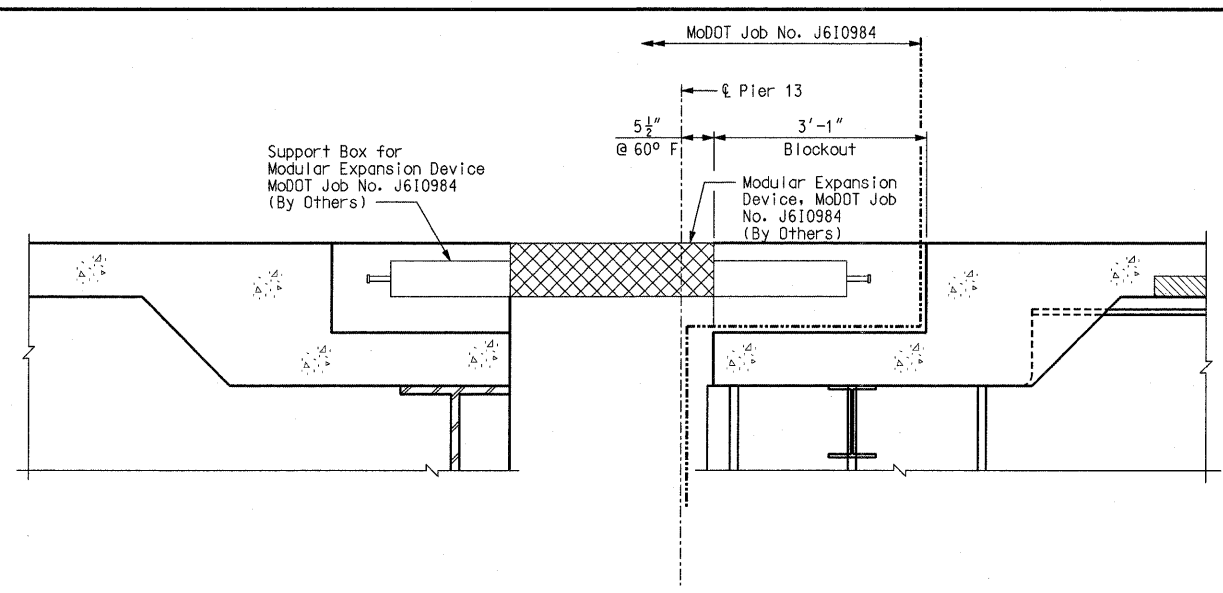

SECTION A-A

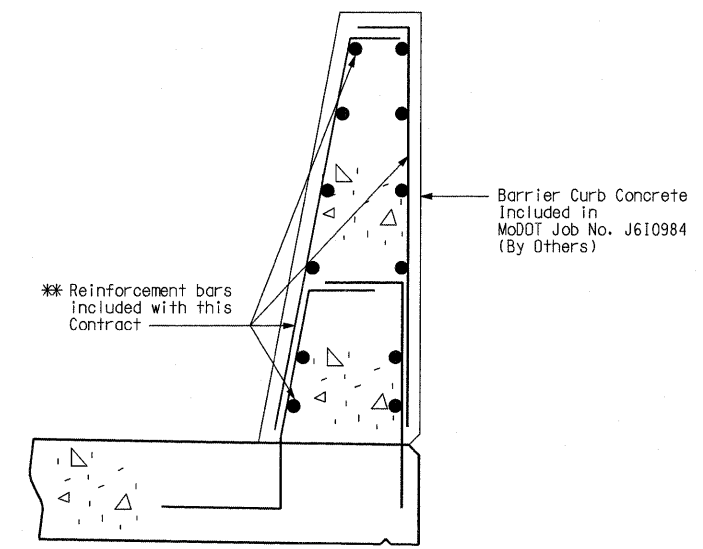

SECTION D-D

Notes:
Design movements for Modular Expansion Device shall be determined by the main span contractor MoDOT Job No. J610984 (By Others)
For slab reinforcing at Expansion Joints, see Sheet No. 100.
** For details of Barrier Curb (Type D), see Sheet Nos. 109 thru 118.

MODULAR EXPANSION JOINT DETAILS EB - PIER 13

CONTRACT NO. 76D61	
F.A. ROUTE	SECTION
999	82-1B-2
FED. AID PROJECT	ILLINOIS
COUNTY	ST. CLAIR
USER NAME = jjoilliff	
PLOT SCALE = #SCALE#	
PLOT DATE = 4/14/2010	
DESIGNED -	HNTB
CHECKED -	CMT
DRAWN -	CMT / HNTB
REVISED -	
REVISED -	
REVISED -	
REVISED -	

ILLINOIS APPROACH STRUCTURE
FOR NEW I-70 MISSISSIPPI RIVER BRIDGE

STATE OF ILLINOIS
DEPARTMENT OF TRANSPORTATION
MISSOURI HIGHWAYS
AND TRANSPORTATION COMMISSION

HNTB
715 KIRK DRIVE
KANSAS CITY, MO 64105
TELEPHONE (816) 472-1201
CERTIFICATE OF AUTHORITY
NO. 001270

CMT
CRANFORD, MURPHY & TILLY, INC.
2750 WEST WASHINGTON STREET
SPRINGFIELD, IL 62702
TELEPHONE (217) 787-8050
ENGINEERING CORPORATION - 000631