

PLAN

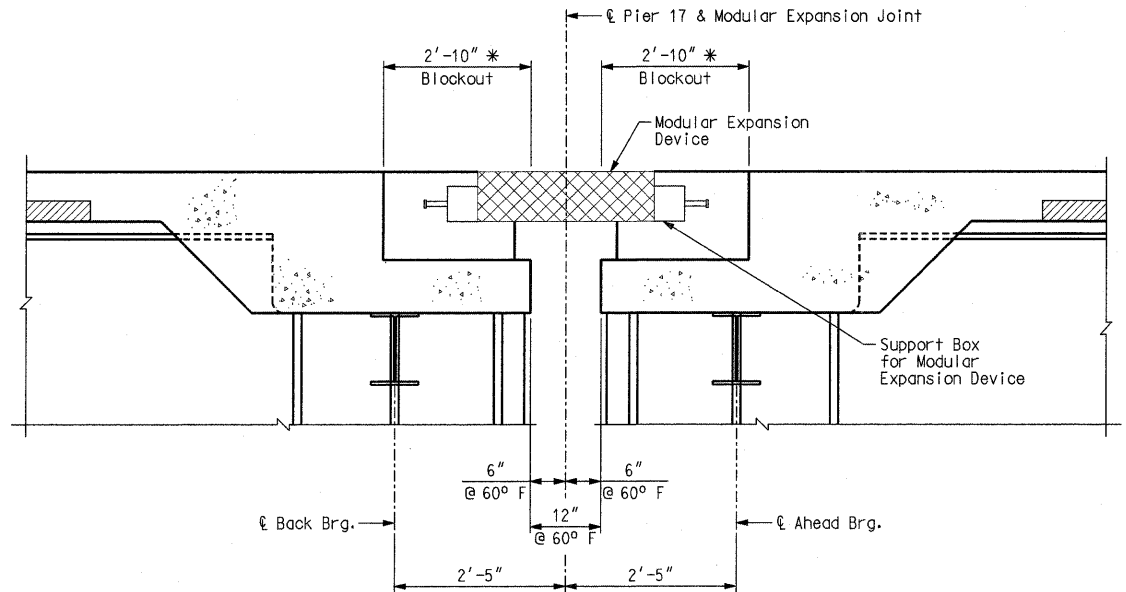

SECTION A-A

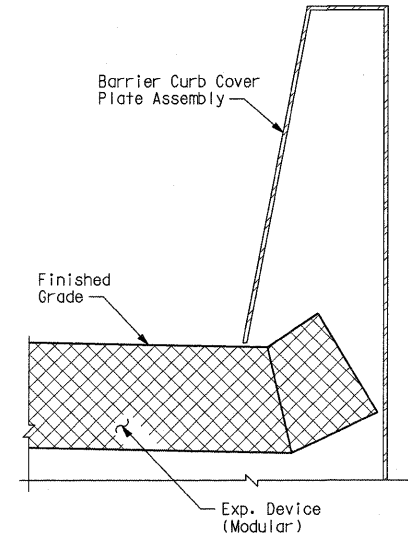

SECTION B-B

Notes:  
 Design movements for Modular Expansion Device are 5.93 inches for closing and 8.90 inches for opening (LRFD Service I).  
 For slab reinforcing at Expansion Joints, see Sheet No. 100.  
 For details of Barrier Curb (Type D), see Sheets Nos. 109 thru 118.  
 For details of Barrier Curb Cover Plate Assembly, see Sheets Nos. 119 and 120.  
 The cost of materials, fabrication, and installation of Expansion Joint shall be included in the pay item "Modular Expansion Joint".  
 \* Dimensions dependent upon Modular Expansion Joint selection.  
 Contractor is responsible for coordinating any revisions required due to deviations from dimensions shown.  
 For additional requirements for Modular Expansion Device, see Special Provisions.

MODULAR EXPANSION JOINT DETAILS EB - PIER 17

Detailed JUL 2009  
 Checked JUL 2009

Note: This drawing is not to scale. Follow dimensions.

Sheet No. 124 of 152

s:\dot\0906601\draw\_idot\cadd\_sheets\structural\B\_A6500\_124-152\_J610984C\_124.dgn

CONTRACT NO. 76D61	
F.A. ROUTE	SECTION
999	82-1B-2
FED. AID PROJECT	ILLINOIS
COUNTY	ST. CLAIR
USER NAME = jjo11ff	
PLOT SCALE = 4SCALE4	
PLOT DATE = 4/14/2010	
DESIGNED -	HNTB
CHECKED -	CMT
DRAWN -	CMT / HNTB
REVISED -	
REVISED -	
REVISED -	
REVISED -	

ILLINOIS APPROACH STRUCTURE  
 FOR NEW I-70 MISSISSIPPI RIVER BRIDGE

STATE OF ILLINOIS  
 DEPARTMENT OF TRANSPORTATION  
 MISSOURI HIGHWAYS  
 AND TRANSPORTATION COMMISSION



715 KIRK DRIVE  
 KANSAS CITY, MO 64105  
 TELEPHONE (816) 472-1201  
 CERTIFICATE OF AUTHORITY  
 NO. 001270



CRAWFORD, MURPHY & TILLY, INC.  
 2750 WEST WASHINGTON STREET  
 SPRINGFIELD, IL 62702  
 TELEPHONE (217) 787-8050  
 ENGINEERING CORPORATION - 000631