

NOTE:

- FOR BIKE LANE SYMBOLS ONLY, USE PRE-FORMED THERMOPLASTIC WITH A MINIMUM THICKNESS OF 90 MILS, MINIMUM SKID RESISTANCE VALUE OF 60 BPN, & A MINIMUM INDEX OF REFRACTION OF 1.50.
- THE RESIDENT ENGINEER SHALL CONTACT MR. BEN GOMBERG AT 312-744-8093 AT LEAST ONE CALENDAR WEEK PRIOR TO INSTALLING BIKE LANE SYMBOLS.

TYPICAL BIKE LANE SYMBOLS
DRAWING #28

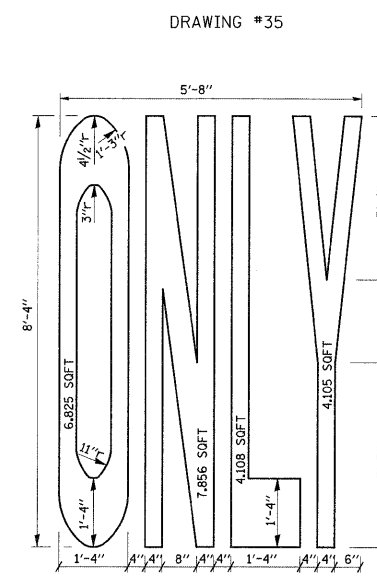
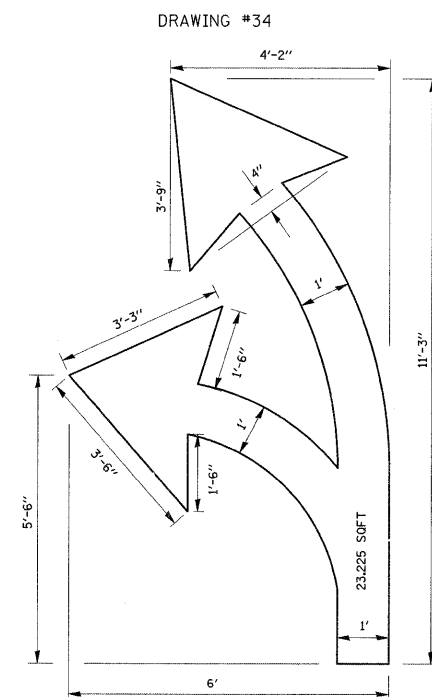
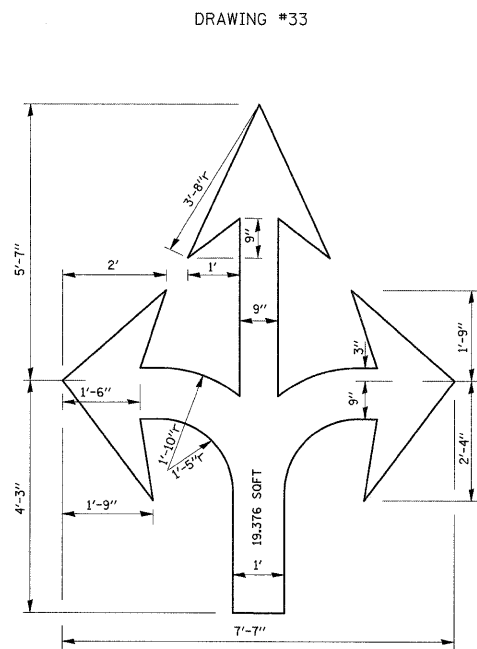
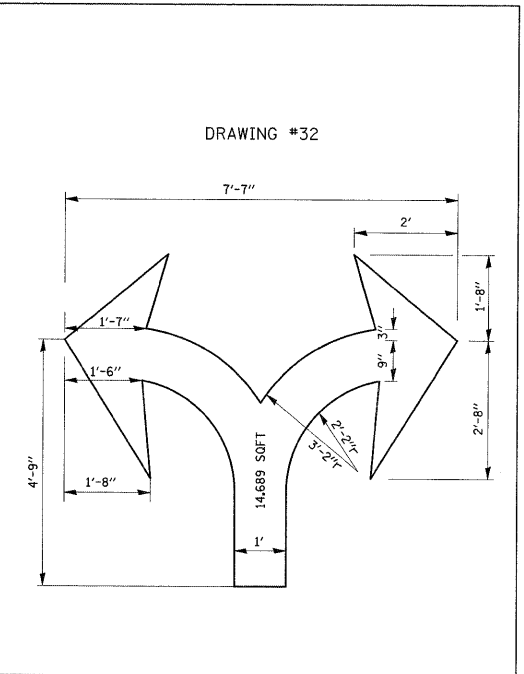
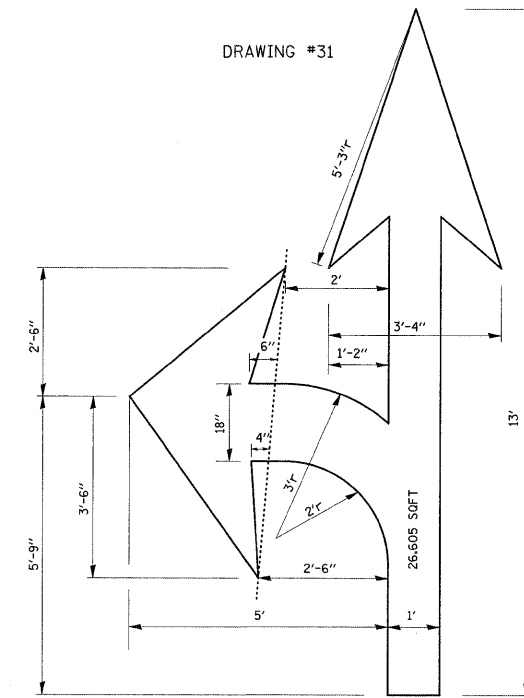
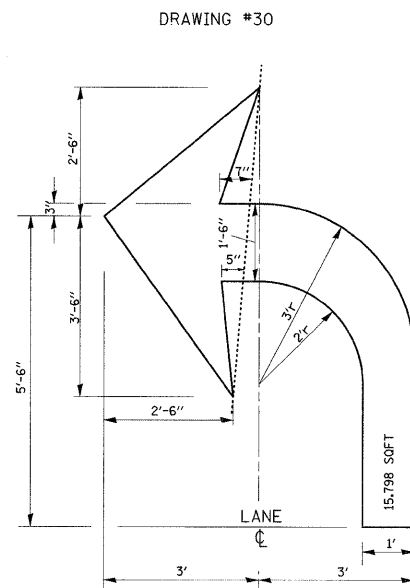
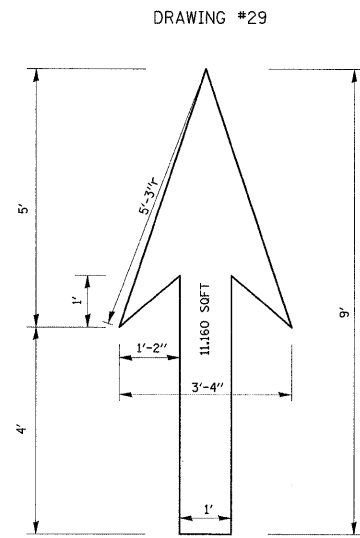

NOTE:

ALL MARKINGS SHALL BE SOLID WHITE UNLESS OTHERWISE NOTED IN THE PLANS

FILE NAME =	USER NAME = rodriguezj	DESIGNED -	REVISED - T. RAMMACHER 12-07-00
c:\pwork\pwork\rodriguezj\d0126805\ds1std.dgn		DRAWN -	REVISED -
PLOT SCALE = 50.0000 1/1 IN.		CHECKED -	REVISED -
PLOT DATE = 4/23/2009		DATE -	REVISED -

STATE OF ILLINOIS
DEPARTMENT OF TRANSPORTATION

CITY OF CHICAGO
TYPICAL PAVEMENT MARKINGS

SCALE: NONE SHEET NO. 2 OF 2 SHEETS STA. TO STA.

F.A.O. RTE.	SECTION	COUNTY	TOTAL SHEETS	SHEET NO.
2715	0101 AS-04	Cook	17	16
	TC-24		CONTRACT NO. 60A51	
FED. ROAD DIST. NO. 1 ILLINOIS FED. AID PROJECT				