

**127th STREET
EXIST. TYPICAL SECTION**
STA. 3+70.6 TO STA. 9+44.1

LEGEND

- ① EXIST. PCC BASE COURSE, 9''(±)
- ② EXIST. REMAINING HMA AFTER MILLING, 1 1/4''(±)
- ③ EXIST. COMBINATION CONCRETE CURB & GUTTER
- ④ PROP. PORTLAND CEMENT CONCRETE SURFACE REMOVAL, (VARIABLE DEPTH) (0'' TO 1 1/4'')
- ⑤ PROP. HOT-MIX ASPHALT SURFACE REMOVAL - 2 1/4''
- ⑥ PROP. HOT-MIX ASPHALT SURFACE COURSE, MIX "D", N70, 1 1/2''
- ⑦ PROP. POLYMERIZED LEVELING BINDER (MM), IL-4.75, N50, 3/4''
- ⑧ PROP. POLYMERIZED LEVELING BINDER (MM), IL-4.75, N50, 1''

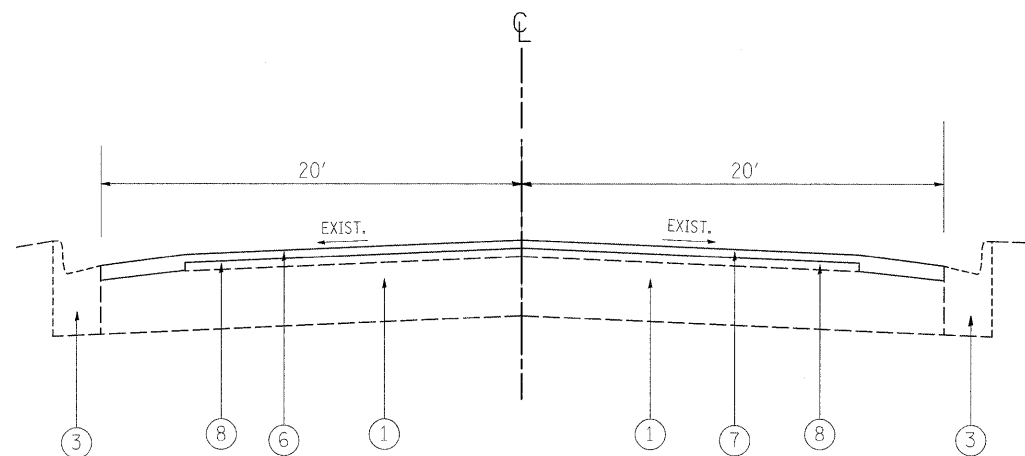

**127th STREET
PROP. TYPICAL SECTION**
STA. 3+70.6 TO STA. 9+44.1

NOTE:

THE CONTRACTOR SHALL PATCH FIRST THEN MILL

FILE NAME =	USER NAME = abebawa	DESIGNED -	REVISED -	STATE OF ILLINOIS DEPARTMENT OF TRANSPORTATION	127TH STREET (KEDZIE AVENUE TO MAPLE AVENUE) TYPICAL SECTIONS	F.A.B. RTE.	SECTION	COUNTY	TOTAL SHEETS	SHEET NO.
ct:\pw_work\pwwdot\abebawa\0128251\0102	09-shi-plan.dgn	DRAWN -	REVISED -			344	3034-1A-RS	COOK	20	5
	PLOT SCALE = 50,0000' / IN.	CHECKED -	REVISED -			CONTRACT NO. 60F08				
	PLOT DATE = 3/20/2009	DATE -	REVISED -			SCALE:	SHEET NO. OF SHEETS	STA. TO STA.	FED. ROAD DIST. NO. 1 ILLINOIS FED. AID PROJECT	