

CRAWFORD AVE.

EXISTING TYPICAL SECTION

STA. 23+82 TO STA. 63+81
 STA. 79+63 TO STA. 88+14
 STA. 91+17 TO STA. 122+16
 STA. 143+29 TO STA. 192+01
 STA. 201+08 TO STA. 243+86
 STA. 259+31 TO STA. 266+49

LEGEND

- ① EXISTING HOT-MIX ASPHALT SURFACE, 7 1/4" (+/-)
- ② EXISTING P.C.C. BASE COURSE, 8" (+/-)
- ③ EXISTING COMBINATION CONCRETE CURB & GUTTER, TYPE B-6.12
- ④ EXISTING HOT-MIX ASPHALT SHOULDER,
- ⑤ EXISTING AGGREGATE SHOULDER
- ⑥ PROPOSED HOT-MIX ASPHALT SURFACE REMOVAL, 2 1/4"
- ⑦ PROPOSED HOT-MIX ASPHALT SURFACE COURSE, MIX "D", N70, 1 1/2"
- ⑧ PROPOSED POLYMERIZED LEVELING BINDER (MACHINE METHOD), IL-4.5, N50, 3/4"
- ⑨ PROPOSED AGGREGATE WEDGE SHOULDER, TYPE B
- ⑩ PROPOSED GRADING AND SHAPING SHOULDERS

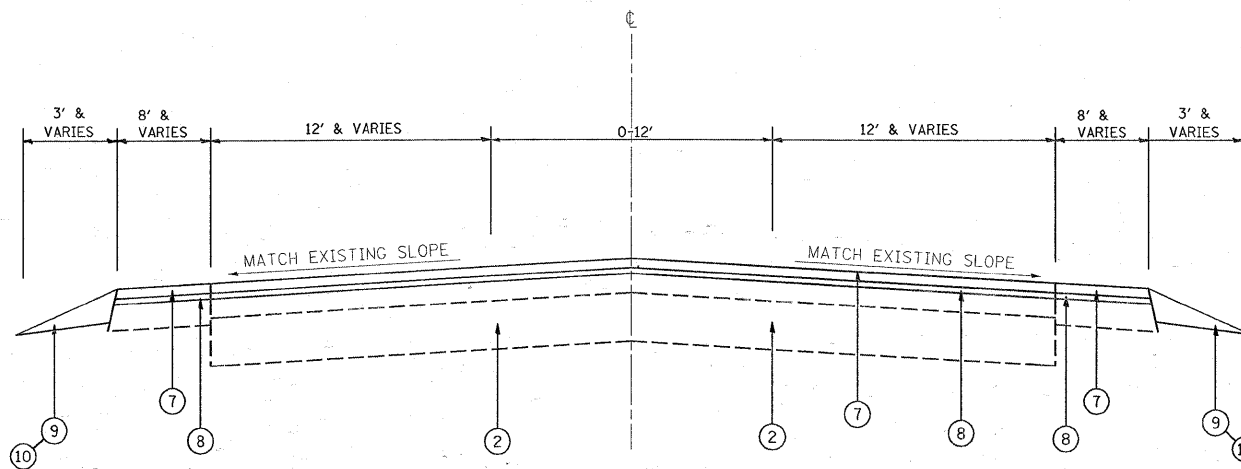

CRAWFORD AVE.

PROPOSED TYPICAL SECTION

STA. 23+82 TO STA. 63+81
 STA. 79+63 TO STA. 88+14
 STA. 91+17 TO STA. 122+16
 STA. 143+29 TO STA. 192+01
 STA. 201+08 TO STA. 243+86
 STA. 259+31 TO STA. 266+49

NOTE:

MILLING TO BE DONE PRIOR TO PATCHING.

FILE NAME =	USER NAME = bankal	DESIGNED - -	REVISED - -	STATE OF ILLINOIS DEPARTMENT OF TRANSPORTATION	CRAWFORD AVENUE- I-80 TO US 30 (LINCOLN HIGHWAY) EXISTING AND PROPOSED TYPICAL SECTIONS	F.A.U. RTE.	SECTION	COUNTY	TOTAL SHEETS	SHEET NO.	
c:\pwork\pwork\bankal\dms01328\sh_rdg.dgn		DRAWN - -	REVISED - -			3778	(3143 & 3144) RS-1	COOK	29	5	
PLOT SCALE = 50.0000' / IN.		CHECKED - -	REVISED - -			CONTRACT NO. 60F44					
PLOT DATE = 3/24/2009		DATE - -	REVISED - -			FED. ROAD DIST. NO. 1 ILLINOIS FED. AID PROJECT					
				SCALE:	SHEET NO. 3 OF 31 SHEETS	STA.	TO STA.				