

ROUTE		SECTION	COUNTY	SHEET	
F.A.P.	VAR.	*	PEORIA	TOTAL	NO.
MKD.	IL 90			100	77

* (108X, 130, 102)RS-3; 129RS-4, 101RS-2

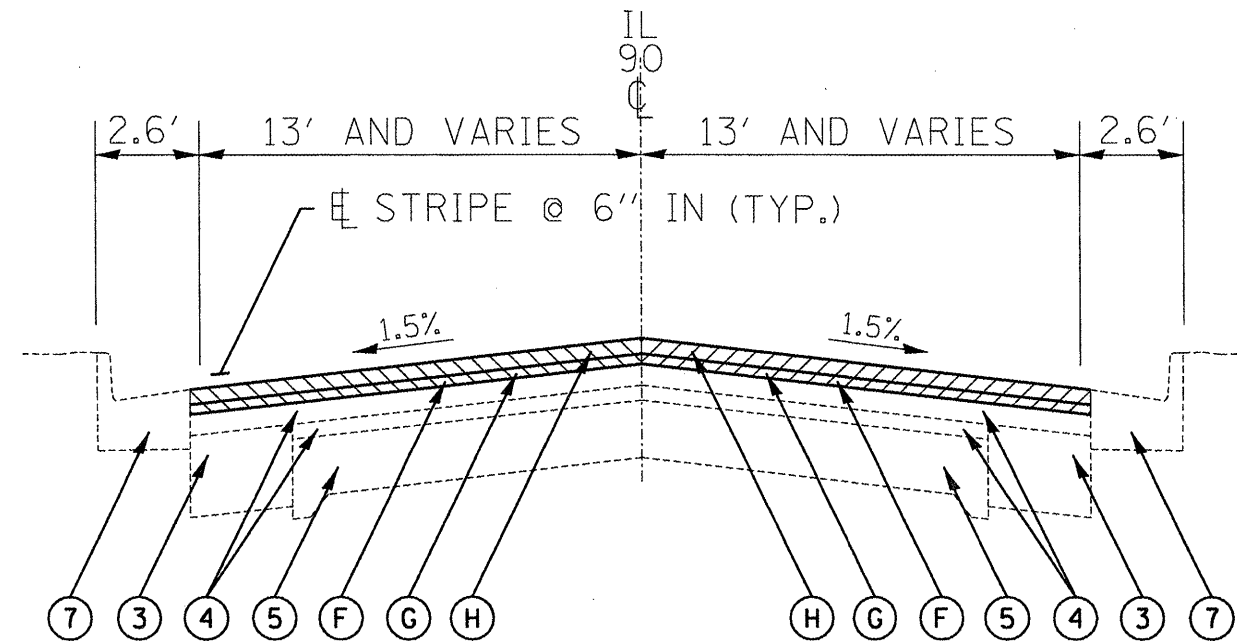

LEGEND

- ① EXISTING AGGREGATE SHOULDERS
- ② EXISTING HMA SHOULDERS
- ③ EXISTING HMA PAVEMENT WIDENING
- ④ EXISTING HMA OVERLAY
- ⑤ EXISTING P.C.C. PAVEMENT
- ⑥ EXISTING CONCRETE GUTTER TYPE A MODIFIED
- ⑦ EXISTING C.C.C. & G TYPE B 6.24
- Ⓐ PROPOSED AGGREGATE SHOULDERS
- Ⓑ PROPOSED HMA SHOULDERS (1 1/2")
- Ⓒ PROPOSED HMA SURFACE REMOVAL, 3/4"
- Ⓓ PROPOSED HMA SURFACE REMOVAL, 1 1/4"
- Ⓔ PROPOSED HMA SURFACE REMOVAL, 1 1/2"
- Ⓕ PROPOSED HMA SURFACE REMOVAL, 2 "
- Ⓖ PROPOSED POLYMERIZED HMA LEVELING BINDER (MACHINE METHOD), N50, IL 4.75 (3/4")
- Ⓗ PROPOSED HMA SURFACE CSE, MIX "D", N50, IL 9.5 OR 12.5 (1 1/2")

STATION EQUATION 113+70.60 (BK) = 113+69.59 (AH)
 STATION EQUATION 332+01.31 (BK) = 10+70.84 (AH)
 (BRIDGE OMISSION STA. 114+97 TO STA. 115+63)
 IL 90 STA. 123+50 TO STA. 149+02.31
 STATION EQUATION 149+02.31 (BK) = 592+04.48 (AH)
 IL 90 STA. 592+04.48 TO STA. 590+93.00

TYPICAL SECTIONS
 (NOT TO SCALE)