

**BRIDGE APPROACH PAVEMENT CONNECTOR (PCC)**

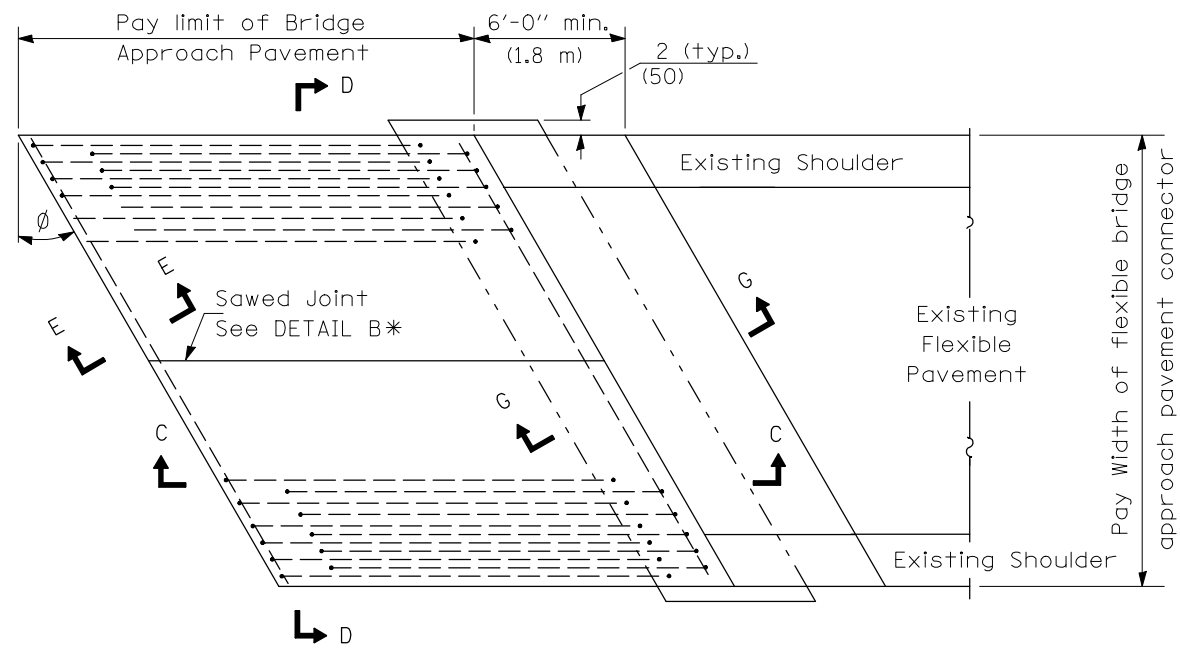

**BRIDGE APPROACH PAVEMENT CONNECTOR (FLEXIBLE)**

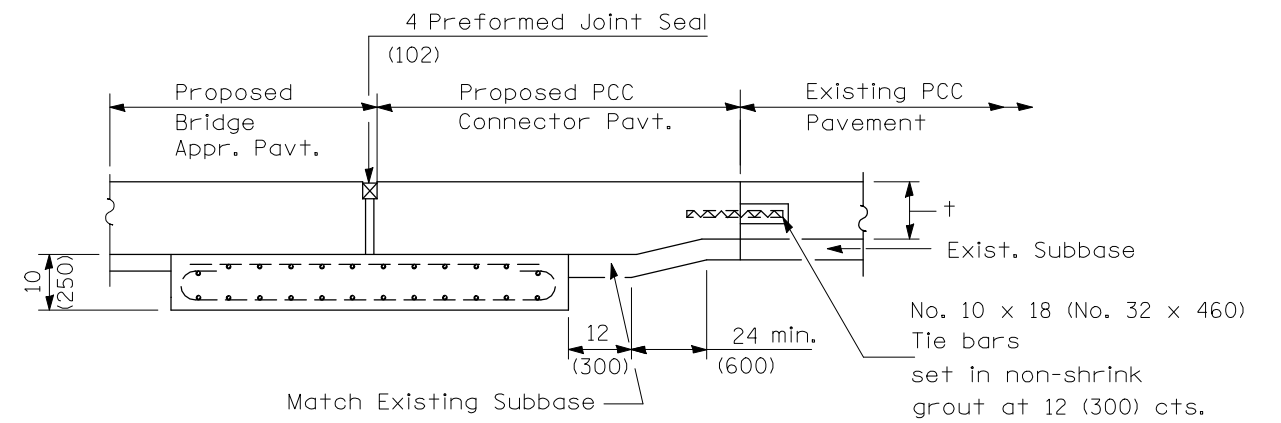

**SECTION G-G - RIGID PAVEMENT**

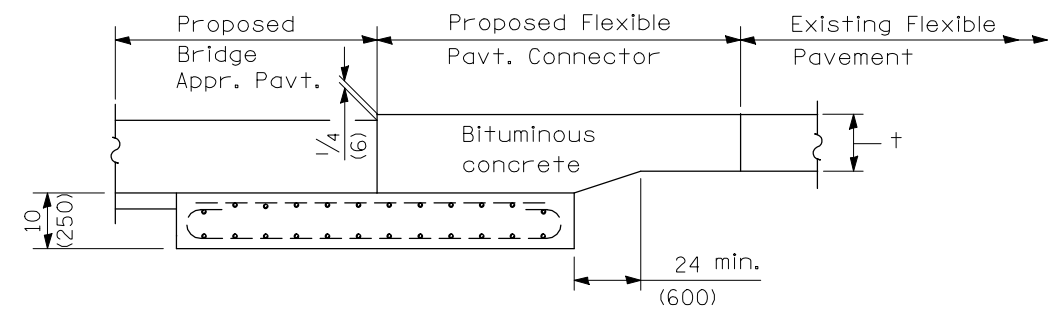

**SECTION G-G - FLEXIBLE PAVEMENT**

SCALE:		SHEET NO. 2 OF 4 SHEETS		STA. TO STA.		F.A.I. RTE.	SECTION	COUNTY	TOTAL SHEETS	SHEET NO.
						74	(57-22B-1)BR	MCLEAN	46	38
ILLINOIS FED. AID PROJECT										

**BRIDGE APPROACH PAVEMENT DETAIL**

CONTRACT NO. 70721