

- ALL EDGES OF NEW SLABS, FREE STANDING OR CLOSURE, SHALL BE EDGED WITH AN APPROVED TOOL HAVING A RADIUS OF 1/8" TO 1/4" TO FACILITATE SAWING OF THE SEALANT RESERVOIR. A RADIUS > 1/4" WILL NOT BE ACCEPTABLE.
- THE INITIAL SAWCUT FOR ALL LONGITUDINAL AND TRANSVERSE CONTRACTION JOINTS SHALL BE SAWS AS SOON AS POSSIBLE AFTER PLACEMENT OF THE PAVEMENT. SAWING OF LONGITUDINAL CONTRACTION JOINTS ADJACENT TO THE THICKENED EDGES SHALL BE GIVEN PRIORITY OVER OTHER LONGITUDINAL JOINT SAWING.
- ALL DOWEL BARS SHALL BE SECURELY HELD IN PLACE BY MEANS OF A DOWEL BAR ASSEMBLY INSTALLED PER ARTICLE 420.05 JOINTS OF THE ILLINOIS DEPARTMENT OF TRANSPORTATION "STANDARD SPECIFICATIONS FOR ROAD AND BRIDGE CONSTRUCTION", WHICH WILL INSURE THAT THEY WILL REMAIN PARALLEL TO THE PAVEMENT LANES. THE DOWEL BAR ASSEMBLIES SHALL BE APPROVED BY THE ENGINEER PRIOR TO INSTALLATION.
- ALL TIE BARS AND MESH SHALL BE SECURELY HELD IN PLACE BY SUPPORT PINS OR PLACED BY OTHER APPROVED METHODS TO PREVENT SHIFTING DURING AND AFTER CONCRETE PLACEMENT.
- TIE BARS SHALL BE DEFORMED BARS IN CONFORMANCE WITH ASTM A615 OR ASTM A616, EXCEPT THAT RAIL STEEL BARS, GRADE 50 OR 60 SHALL NOT BE USED FOR THE BARS THAT ARE TO BE BENT OR RESTRAINED DURING CONSTRUCTION. TIE BARS DESIGNATED AS GRADE 40 IN ASTM A615 CAN BE USED FOR CONSTRUCTION REGARDING BENT BARS.
- THE INITIAL SAWCUT SHALL BE MADE TO THE 1/8" WIDTH INDICATED. INITIAL SAWING TO THE DIMENSION OF THE SECOND SAWCUT WILL NOT BE ALLOWED.
- JOINTS SHALL BE DRY AND CLEAN BEFORE SEALING OPERATIONS BEGIN.
- COST OF ALL JOINT SAWING, CLEANING AND SEALING OF NEW CONCRETE PAVEMENT SHALL BE CONSIDERED INCIDENTAL TO THE ASSOCIATED PAY ITEM AND NO SEPARATE PAYMENT SHALL BE MADE.
- SHOULD THE POURING OPERATIONS REQUIRE THE INSERTION OF AN INTERMEDIATE HEADER, A DOWEL BASKET ASSEMBLY OR OTHER APPROVED METHOD OF DOWEL BAR PLACEMENT SHALL BE REQUIRED.
- DOWEL BASKET ASSEMBLIES MEETING IDOT APPROVAL MAY BE PROPOSED BY THE CONTRACTOR TO BE APPROVED BY THE ENGINEER. DOWELS IN THE APPROVED BASKET ASSEMBLIES SHALL CONFORM TO TABLE 2.
- CONTRACTOR SHALL CONSTRUCT A 1/4" CHAMFER ON ALL CONCRETE JOINTS AT NO ADDITIONAL COST.

REVISIONS		
NUMBER	BY	DATE

CONTRACTION JOINTS

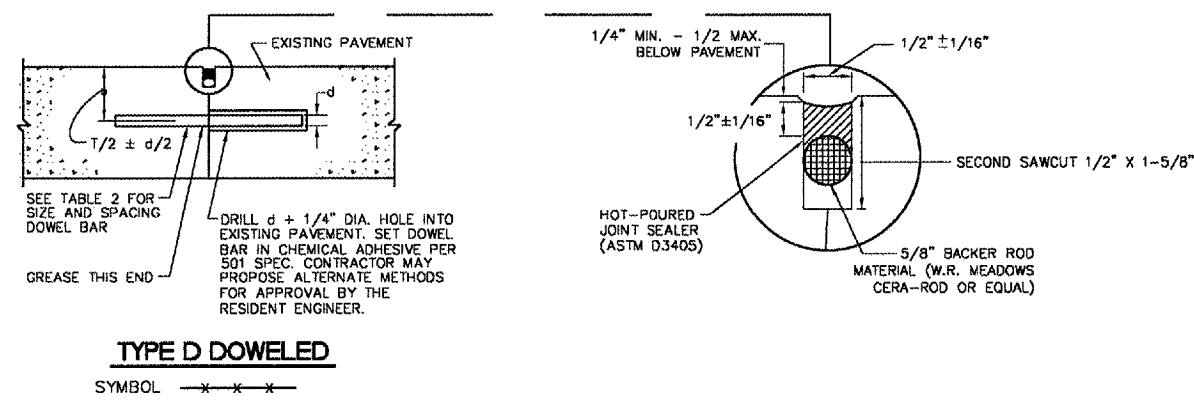

CONSTRUCTION JOINTS

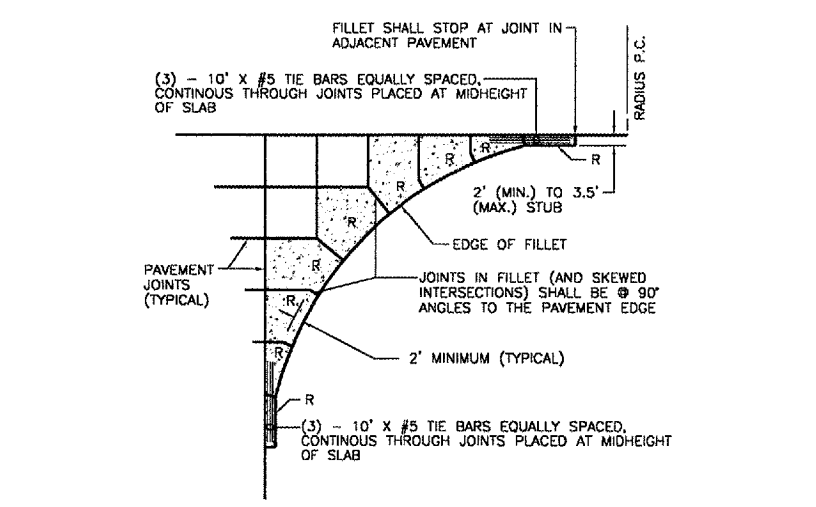
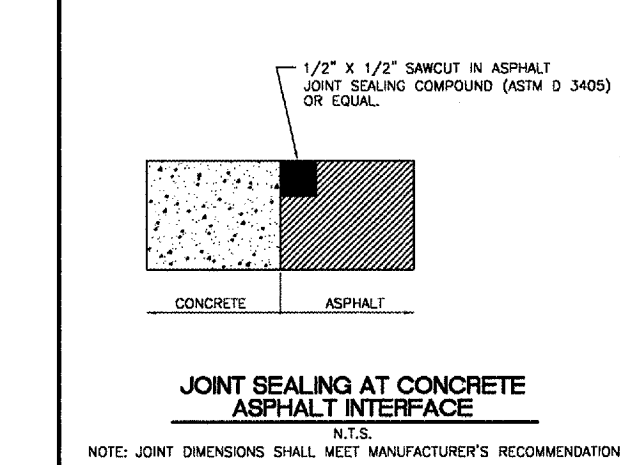
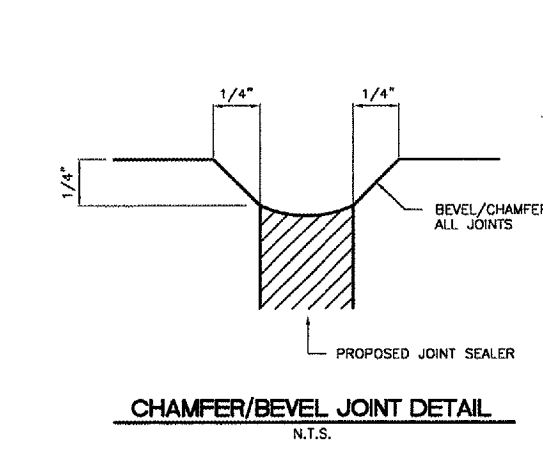

FILLET DETAIL AND FILLET REINFORCING LAYOUT
 N.T.S.

R DENOTES ODD SHAPED REINFORCED PANELS TO BE REINFORCED WITH DEFORMED WIRE FABRIC AS SHOWN ON THIS SHEET. ALL NON RECTANGULAR SHAPED PANELS SHALL BE REINFORCED. (REINFORCEMENT NOT SHOWN)

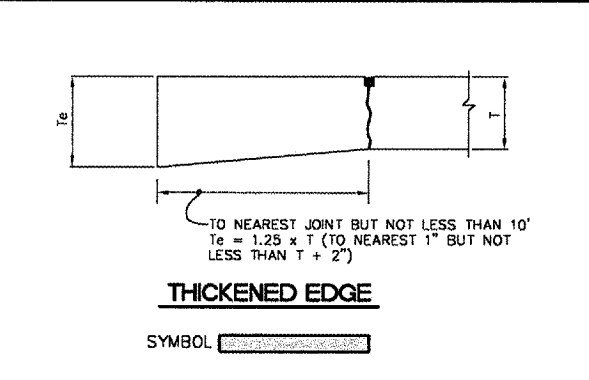
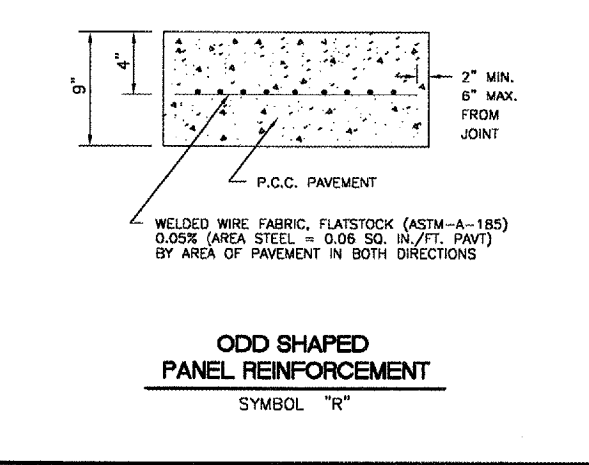
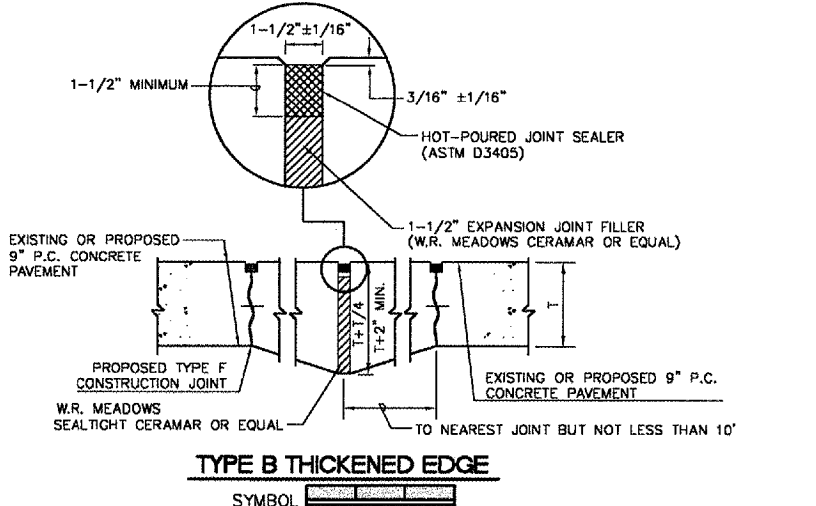

TABLE 1

PAVEMENT THICKNESS T - INCHES	DEPTH OF CONTRACTION JOINT INITIAL SAW CUT T _i INCHES T _i =(T/4) ± 1/4"
6	1.50"
7	1.75"
8	2.00"
9	2.25"
10	2.50"
11	2.75"
12	3.00"

TABLE 2

PAVEMENT THICKNESS T - INCHES	DOWEL BAR DETAILS			TIE BAR DETAILS		
	DIA. (d)	LENGTH	SPACING	BAR SIZE	LENGTH	SPACING
6	3/4"	18"	12"	#5	30"	30"
7	3/4"	18"	12"	#5	30"	30"
8	1"	19"	12"	#5	30"	30"
9	1"	19"	12"	#5	30"	30"
10	1"	19"	12"	#5	30"	30"
11	1"	19"	12"	#5	30"	30"
12	1"	19"	12"	#5	30"	30"



EXPANSION JOINTS

DIMENSION TABLES

**AURORA MUNICIPAL AIRPORT
 AURORA, ILLINOIS
 REHABILITATE AND STRENGTHEN TAXIWAY ALPHA
 ENDS AND CONNECTING TAXIWAYS - PHASE 2**

PAVEMENT JOINTING DETAILS

CMT
 CRAWFORD, MURPHY & TILLY, INC.
 CONSULTING ENGINEERS
 License No. 184-000613

DESIGN BY: DKP
 DRAWN BY: JRO
 CHECKED BY:
 APPROVED BY:
 DATE: 10/31/07
 JOB No: 07285-04
 ILLINOIS PROJECT: ARR-3770
 A.I.P. PROJECT: 3-17-0003-836
FINAL SUBMITTAL
 SHEET 13 OF 23 SHEETS