

**SOIL PROTECTION CHART**

STABILIZATION TYPE	JAN	FEB	MAR	APR	MAY	JUNE	JULY	AUG	SEPT	OCT	NOV	DEC
PERMANENT SEEDING			+A		+A1					+A1		
DORMANT SEEDING	B										+B	
TEMPORARY SEEDING			+C			D						
SODDING			**E									
MULCHING	F											

- A KENTUCKY BLUEGRASS 100 LBS/ACRE  
 PERENNIAL RYEGRASS 60 LBS/ACRE  
 CREEPING RED FESCUE 40 LBS/ACRE
- B KENTUCKY BLUEGRASS 100 LBS/ACRE  
 PERENNIAL RYEGRASS 60 LBS/ACRE  
 CREEPING RED FESCUE 40 LBS/ACRES
- C SPRING OATS 100 LBS/ACRE  
 D WHEAT OR CEREAL RYE 150 LBS/ACRE
- E SOD  
 F HYDROMULCH 2 TON/ACRE
- \* IRRIGATION NEEDED DURING JUNE AND JULY  
 \*\* IRRIGATION NEEDED FOR A MINIMUM 3 TO 4 WEEKS AFTER APPLYING SOD

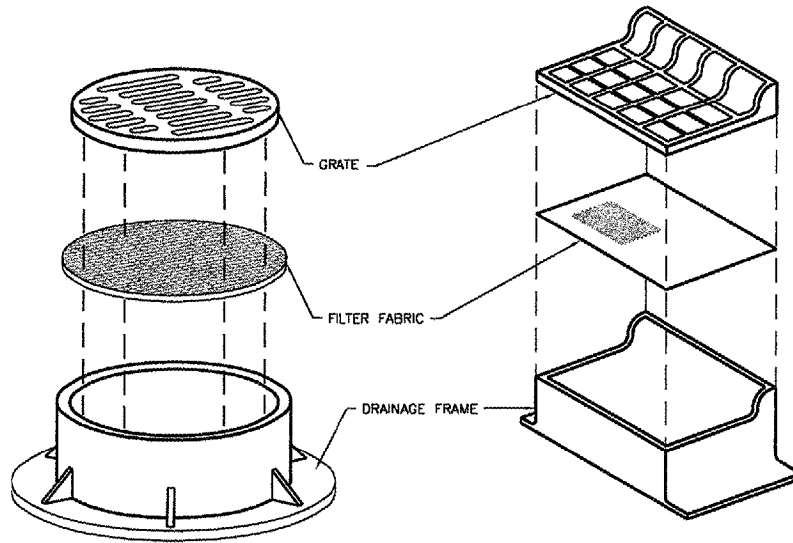

**NOTES:**

1. FILTER WRAP TO BE PLACED IN ALL SLOPE BOXES, INLETS, MANHOLES, TRENCH DRAINS AND CATCH BASINS LOCATED IN PAVED AREAS AND NONPAVED AREAS.
2. FABRIC SHALL BE IN CONFORMANCE WITH MATERIALS SPECIFIED FOR FABRIC FENCE.
3. FABRIC SHALL OVERLAY FRAME BY 2-INCH (MINIMUM).
4. CONTRACTOR SHALL CLEAR DEBRIS AND SILT AS REQUIRED FROM FABRIC TO MAINTAIN DRAINAGE THROUGH THE STRUCTURE.
5. FABRIC SHALL REMAIN IN PLACE UNTIL TURFED AREAS HAVE DEVELOPED A MINIMUM OF 80% OF COVERAGE.
6. COST OF FILTER WRAP SHALL BE CONSIDERED INCIDENTAL TO INLET PROTECTION.

**DRAINAGE STRUCTURE FILTER WRAP**

NOT TO SCALE

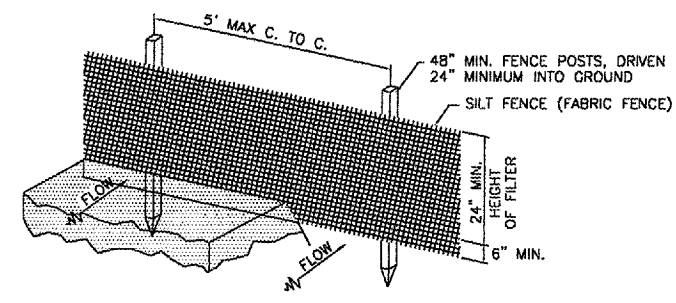

**PERSPECTIVE VIEW**

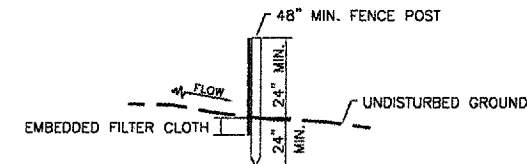

**SECTION**

**EROSION CONTROL FABRIC FENCE DETAIL**

NOT TO SCALE

**CONSTRUCTION NOTES FOR SILT (FABRIC) FENCE**

1. WHEN TWO SECTIONS OF FILTER CLOTH ADJOIN EACH OTHER THEY SHALL BE OVER-LAPPED BY 6-INCH MIN. AND FOLDED.
2. MAINTENANCE SHALL BE PERFORMED AS NEEDED AND MATERIAL REMOVED WHEN "BULGES" DEVELOP IN THE SILT FENCE. MAINTENANCE, WHICH INCLUDES THE REPLACEMENT OF DAMAGED FENCE, SHALL BE CONSIDERED INCIDENTAL TO THE COST OF THE EROSION CONTROL FENCE.
3. SILT FENCE SHALL BE INSTALLED PER GRADING AND LANDSCAPING PLAN OR AS DIRECTED BY THE ENGINEER.

FILE: stormerosd1.dwg  
 LAYOUT: Layout1  
 UPDATE BY: mkatz  
 SURVEY BOOK #  
 DATE: Mon 2/4/08 3:12pm  
 XREF DWG: tbcint.dwg  
 tb.dwg

**REVISIONS**

NUMBER	BY	DATE

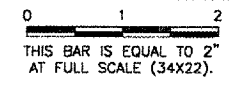

**AURORA MUNICIPAL AIRPORT  
 AURORA, ILLINOIS  
 REHABILITATE AND STRENGTHEN TAXIWAY ALPHA  
 ENDS AND CONNECTING TAXIWAYS - PHASE 2**

**STORM WATER POLLUTION  
 PREVENTION PLAN DETAILS**

**NOTES FOR ALL  
 INLET PROTECTION**

1. SILT FENCE AND SPACERS SHALL NOT BE MEASURED SEPARATELY FOR PAYMENT, BUT WILL BE INCLUDED IN THE UNIT PRICE FOR INLET PROTECTION.
2. INSPECTION SHALL BE FREQUENT AND REPAIR / REPLACEMENT SHALL BE MADE PROMPTLY AS NEEDED.
3. AFTER FINAL APPROVAL OF THE ENGINEER, SILT FENCE MAY BE REMOVED. CONTRACTOR SHALL PLACE SEED AND MULCH OVER THE DISTURBED AREAS.
4. SILT FILTER FABRIC SHALL MEET THE REQUIREMENTS OF MATERIAL SPECIFIED FOR ITEM AR156000 EROSION CONTROL IN THE ILLINOIS DEPARTMENT OF TRANSPORTATION DIVISION OF AERONAUTICS SUPPLEMENTAL SPECIFICATIONS AND REQUIRING SPECIAL PROVISIONS.

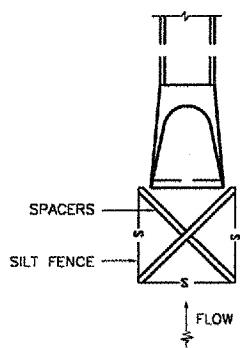

**INLET PROTECTION (END SECTION)**

NOT TO SCALE  
 IDOT STANDARD 280001-03

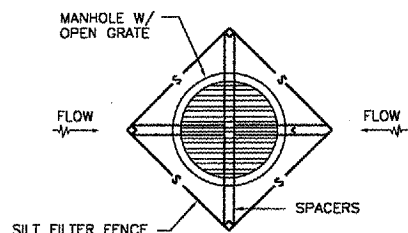

**INLET PROTECTION (INLET/MANHOLES)**

NOT TO SCALE  
 IDOT STANDARD 280001-03

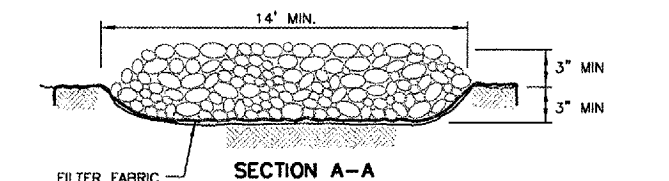

**SECTION A-A**

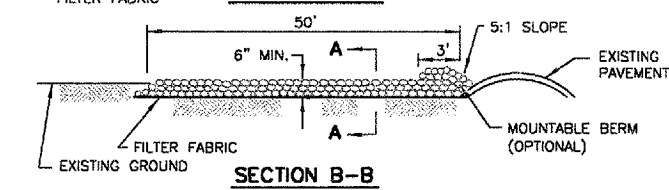

**SECTION B-B**

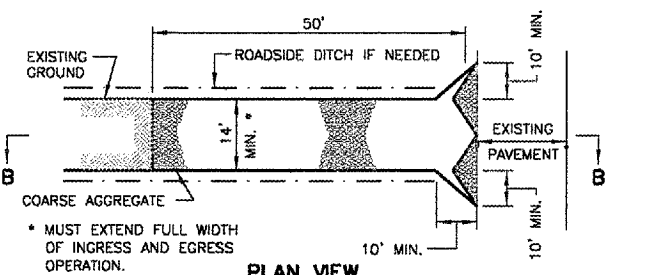

**PLAN VIEW**

**STABILIZED CONSTRUCTION ENTRANCE**

FROM NRCS STANDARD DRAWING NO. IL-630

1. FILTER FABRIC SHALL MEET THE REQUIREMENTS OF MATERIAL SPECIFIED FOR AR152540 IN THE ILLINOIS DEPARTMENT OF TRANSPORTATION DIVISION OF AERONAUTICS SUPPLEMENTAL SPECIFICATIONS AND REQUIRING SPECIAL PROVISIONS.
2. ROCK OR RECLAIMED CONCRETE SHALL MEET ONE OF THE FOLLOWING IDOT COARSE AGGREGATE GRADATION, CA-1, CA-2, CA-3 OR CA-4.
3. ANY DRAINAGE FACILITIES REQUIRED BECAUSE OF WASHING SHALL BE CONSTRUCTED ACCORDING TO MANUFACTURERS SPECIFICATIONS AND SHALL BE INCIDENTAL TO THE CONTRACT.
4. MINIMUM WIDTH IS 14' FOR ONE-WAY TRAFFIC AND 20' FOR TWO WAY TRAFFIC. TWO-WAY TRAFFIC WIDTHS SHALL BE INCREASED A MINIMUM OF 4' FOR TRAILER TRAFFIC. DEPENDING ON THE TYPE OF VEHICLE OR EQUIPMENT, SPEED, LOADS, CLIMATIC AND OTHER CONDITIONS UNDER WHICH VEHICLES AND EQUIPMENT OPERATE AN INCREASE IN THE MINIMUM WIDTHS MAY BE REQUIRED.
5. ROADWAY SHALL FOLLOW THE CONTOUR OF THE NATURAL TERRAIN TO THE EXTENT POSSIBLE.
6. STABILIZED CONSTRUCTION ENTRANCE SHALL BE INCIDENTAL TO THE CONTRACT.

© copyright G.M.T., Inc.  
**G.M.T.**  
 CRAWFORD, MURPHY & TILLY, INC.  
 CONSULTING ENGINEERS  
 License No. 184-000813

DESIGN BY: DKP  
 DRAWN BY: JRO  
 CHECKED BY:  
 APPROVED BY:  
 DATE: 10/31/07  
 JOB No: 07285-04  
 ILLINOIS PROJECT: ARR-3770  
 A.I.P. PROJECT: 3-17-0003-B36  
**FINAL SUBMITTAL**  
 SHEET 17 OF 23 SHEETS