

PLAN	SURVEYED	BY	DATE
NOTE BOOK NO.	PLOTTED		
	CHECKED		
	AT		
	FILE NAME		

PROFILE	SURVEYED	BY	DATE
NOTE BOOK NO.	GRADES CHECKED		
	STRUCTURE		
	NOT AT THIS OFFICE		

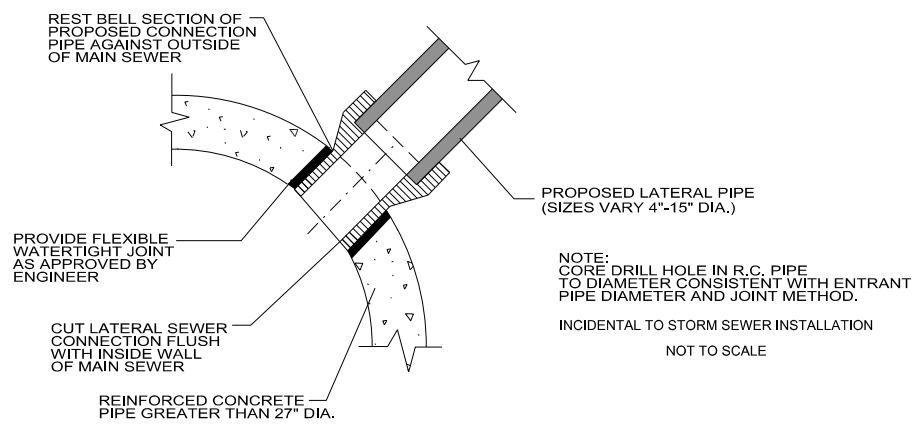

DIRECT CONNECTION DETAIL

DESIGNED	<i>JWM</i>	REVISED	-	STATE OF ILLINOIS DEPARTMENT OF TRANSPORTATION	DRAINAGE DETAILS	F.A.P. RTE.	SECTION	COUNTY	TOTAL SHEETS	SHEET NO.
DRAWN	<i>KES</i>	REVISED	-			338	(112 & 113) WRS-7	DUPAGE	1156	500
CHECKED	<i>JRS</i>	REVISED	-			DD-01		CONTRACT NO. 60R30		
DATE	<i>12/14/2012</i>	REVISED	-			FED. ROAD DIST. NO. ILLINOIS FED. AID PROJECT				
				SCALE: NONE	SHEET NO. 1 OF 2 SHEETS	STA.	TO STA.			