

THE CONTRACTOR SHALL INSTALL A WOOD SUPPORT PLATFORM AS SHOWN ON THE DISTRICT 1 SIGNAL DETAIL SHEETS FOR BOTH THE CONTROLLER CABINET AND UPS.

THE TEMPORARY TRAFFIC SIGNAL CONTROL EQUIPMENT FOR THIS PROJECT SHALL BE "ECONOLITE" TO MATCH THE EXISTING ADJACENT SYSTEM.

RESTORATION OF WORK AREA. RESTORATION OF THE TRAFFIC SIGNAL WORK AREA SHALL BE INCLUDED IN THE RELATED PAY ITEM SUCH AS FOUNDATION, CONDUIT, HANDHOLE, TRENCH AND BACKFILL, ETC., AND NO EXTRA COMPENSATION SHALL BE ALLOWED. ALL ROADWAY SURFACES SUCH AS SHOULDERS, MEDIAN, SIDEWALKS, PAVEMENT ETC. SHALL BE REPLACED IN KIND. ALL DAMAGE TO MOWED LAWNS SHALL BE REPLACED WITH AN APPROVED SOD, AND ALL DAMAGE TO UNMOWED FIELDS SHALL BE SEEDED IN ACCORDANCE WITH STANDARD SPECIFICATIONS 252 AND 250 RESPECTIVELY.

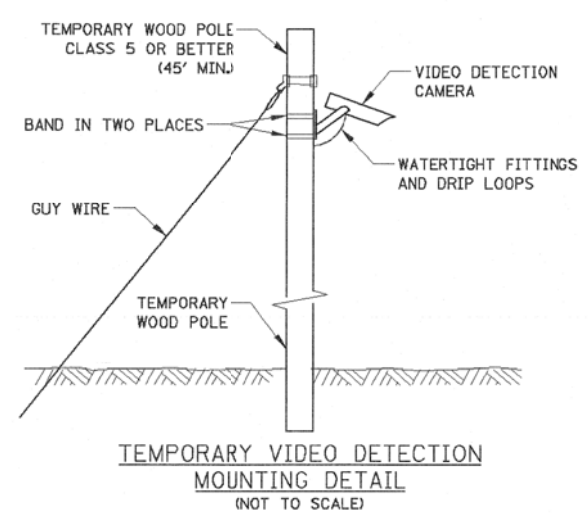

APPROX. STA: 3925+58  
 81' RT

INCLUDED IN THE COST OF TEMPORARY TRAFFIC SIGNAL INSTALLATION

**LEFT ON GREEN ARROW ONLY**

R10-5  
 4 REQUIRED  
 24"X30"  
 SIGN PANEL TYPE 1

**REMOVAL OF EXISTING TRAFFIC SIGNAL EQUIPMENT**

THE FOLLOWING EXISTING TRAFFIC SIGNAL EQUIPMENT SHALL BE REMOVED BY THE CONTRACTOR AND SHALL REMAIN THE PROPERTY OF THE AGENCY LISTED BELOW. THE CONTRACTOR SHALL SAFELY STORE AND ARRANGE FOR PICK UP OF ALL EQUIPMENT TO BE RETURNED TO THE LISTED AGENCY AS PER THE TRAFFIC SIGNAL SPECIFICATIONS.

AGENCY: CITY OF NAPERVILLE  
 2 EACH LIGHT DETECTOR AND BEACON  
 1 EACH LIGHT DETECTOR AMPLIFIER

THE FOLLOWING ITEMS SHALL BE REMOVED BY THE CONTRACTOR AND SHALL BE DISPOSED OF BY THEM OUTSIDE THE RIGHT-OF-WAY AT THEIR EXPENSE. THE SALVAGE VALUE OF THE REMOVED EQUIPMENT SHALL BE REFLECTED IN THE CONTRACT BID PRICE.

- 8 EACH SIGNAL HEAD, 1 - FACE, 3 - SECTION
- 2 EACH SIGNAL HEAD, 1 - FACE, 5 - SECTION
- 2 EACH SIGNAL HEAD, 2 - FACE, 1-3 SECTION, 1-5-SECTION
- 2 EACH SIGNAL HEAD, 2 - FACE, 2-3 SECTION
- 2 EACH PEDESTRIAN SIGNAL HEAD, 1 - FACE
- 10 EACH TRAFFIC SIGNAL BACKPLATE
- 4 EACH STEEL MAST ARM AND POLE
- 4 EACH SIGNAL POST
- 1 EACH SERVICE INSTALLATION
- 1 EACH CONTROLLER AND CABINET (COMPLETE)
- 2 EACH PEDESTRIAN PUSH-BUTTON

\* THE COST FOR THE 2" CONDUIT AND GROUND MOUNTED ELECTRICAL SERVICE SHALL NOT BE INCLUDED IN THE COST FOR TEMPORARY TRAFFIC SIGNAL INSTALLATION AND WILL BE PAID FOR SEPARATELY.

FILE NAME =	USER NAME = \$USER\$	DESIGNED - DW	REVISED -	<b>STATE OF ILLINOIS DEPARTMENT OF TRANSPORTATION</b>	<b>TEMPORARY TRAFFIC SIGNAL INSTALLATION &amp; REMOVE EXISTING TRAFFIC SIGNAL EQUIPMENT PLAN IL RTE 59 AT MEIJER ENTRANCE /WESTRIDGE COURT ENTRANCE</b>	F.A. RTE.	SECTION	COUNTY	TOTAL SHEETS	SHEET NO.
K:\Projects\090059\Design\Sheet Files\6799rwa59tempMRI.dgn		DRAWN - JDH	REVISED -			338	(112 & 113) WRS-7	DUPAGE	1156	614
PLOT SCALE = \$SCALE\$		CHECKED - KMM	REVISED -			<b>TS-22</b>		CONTRACT NO. 60R30		
PLOT DATE = 12/6/2012		DATE -	REVISED -			SCALE: 1"=20'	SHEET NO. 1 OF 3 SHEETS	STA. TO STA.	ILLINOIS FED. AID PROJECT	