

SIDE VIEW (TRUSS ARM)
N.T.S.

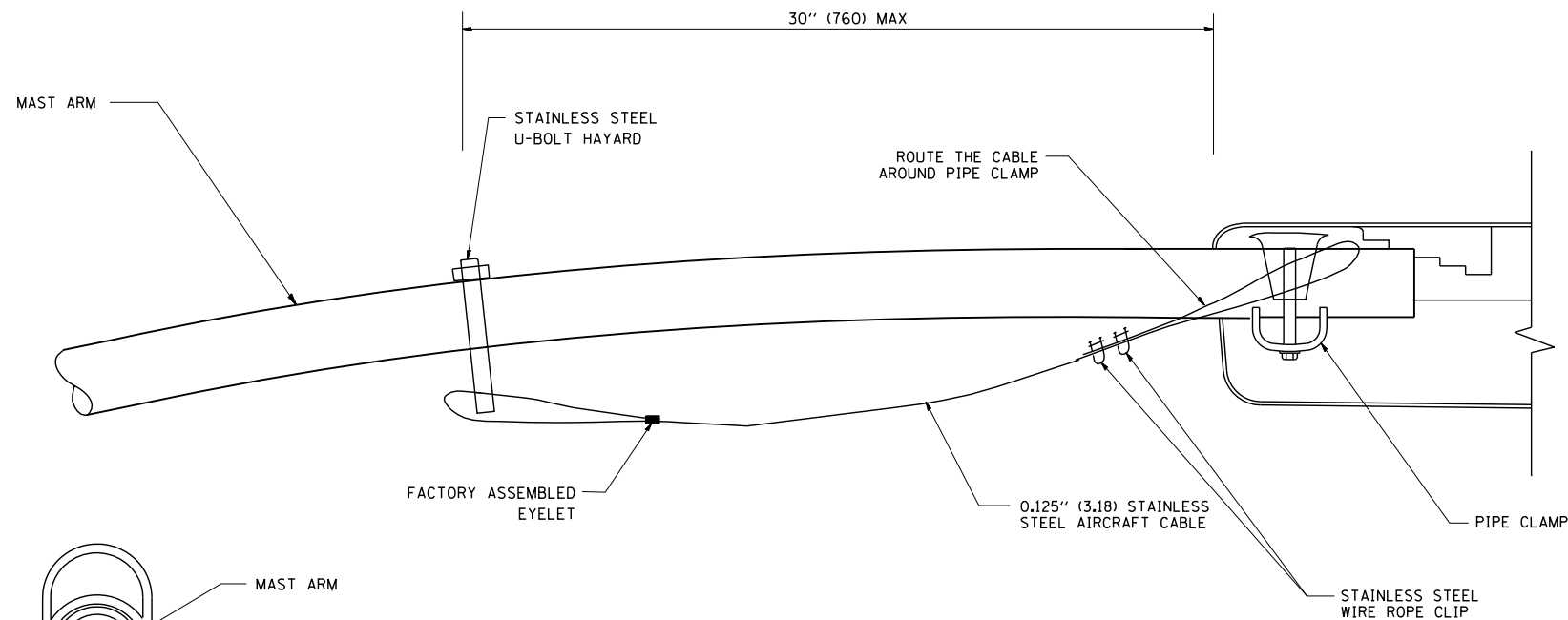

SIDE VIEW (SINGLE MEMBER OR DAVIT ARM)
N.T.S.

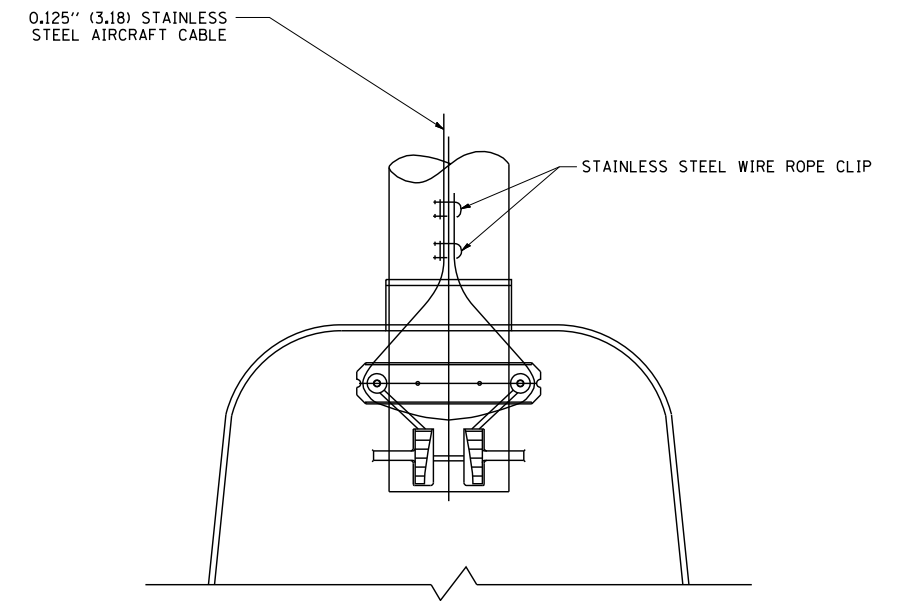
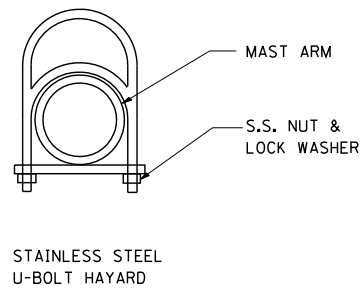

BOTTOM VIEW
N.T.S.

NOTES:

1. ALL DIMENSIONS ARE IN MILLIMETERS (INCHES) UNLESS OTHERWISE SHOWN.
2. CONTRACTOR SHALL ADJUST THE WIRE CLIP TO ELIMINATE ANY SLACK FROM THE WIRE ROPE.
3. THE 0.125" (3.18) STAINLESS STEEL AIRCRAFT CABLE SHALL REMAIN VISIBLE FROM THE GROUND LEVEL.
4. THE BREAKING STRENGTH OF THE CABLE SHALL BE 1700 LBS. MIN.

FILE NAME = W:\diststd\22x34\be701.dgn	USER NAME = gaglianobt	DESIGNED -	REVISED - 08-08-03	STATE OF ILLINOIS DEPARTMENT OF TRANSPORTATION	LUMINAIRE SAFETY CABLE ASSEMBLY			F.A. RTE.	SECTION	COUNTY	TOTAL SHEETS	SHEET NO.	
		DRAWN -	REVISED -		SCALE: NONE	SHEET NO. 1 OF 1 SHEETS	STA.	TO STA.	338	(112 & 113) WRS-7	DUPAGE	1156	903
		PLOT SCALE = 50.000' / IN.	CHECKED -						BE-701		CONTRACT NO. 60R30		
		PLOT DATE = 1/4/2008	DATE -						FED. ROAD DIST. NO. 1 ILLINOIS FED. AID PROJECT				