

SECTION A-A
15' CONCRETE BARRIER TRANSITION
CONCRETE BARRIER, SINGLE FACE, 32 INCH HEIGHT

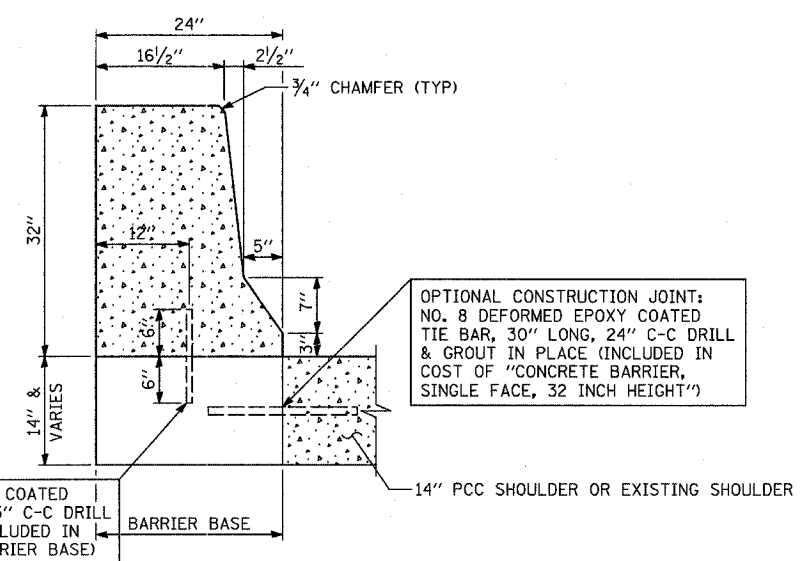

SECTION B-B
CONCRETE BARRIER, SINGLE FACE, 32 INCH HEIGHT
& CONCRETE BARRIER BASE

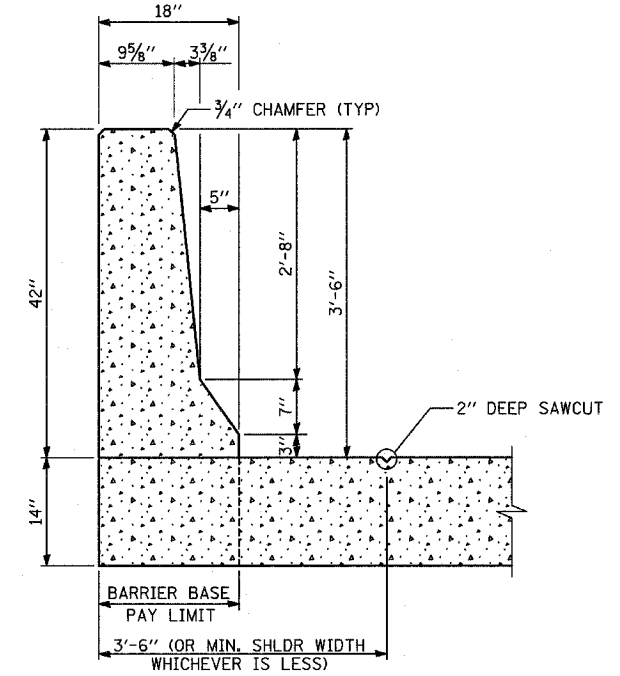

SECTION E-E
CONCRETE BARRIER, SINGLE FACE, 42 INCH HEIGHT
(SPECIAL) DIMENSIONS
SEE BELOW FOR REINFORCEMENT OPTIONS

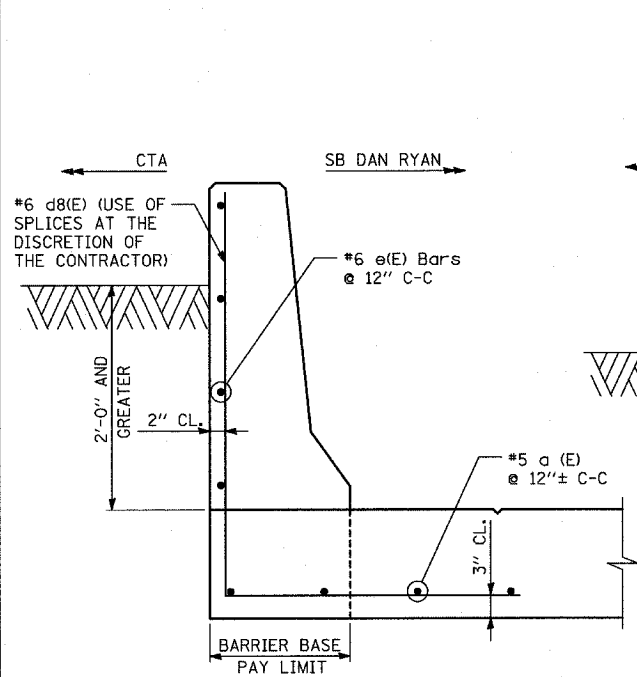

REINFORCEMENT #1
RETAINED HEIGHT GREATER THAN 2'-0"
SECTION E-E: CONCRETE BARRIER, SINGLE FACE, 42 INCH HEIGHT (SPECIAL)

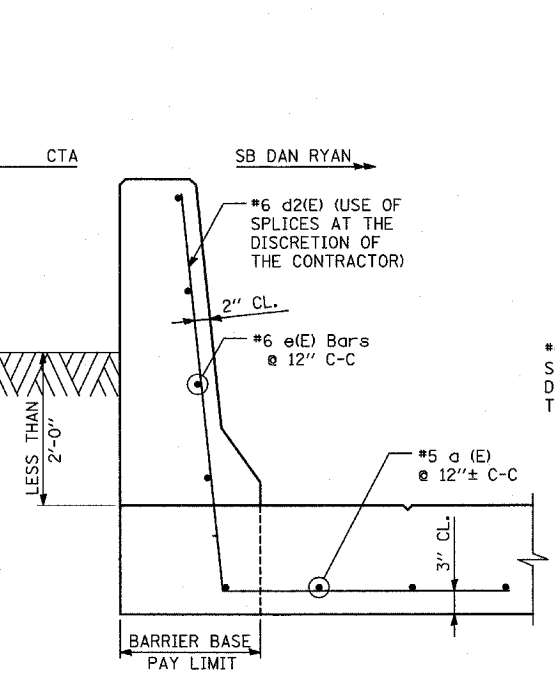

REINFORCEMENT #2
RETAINED HEIGHT LESS THAN 2'-0"

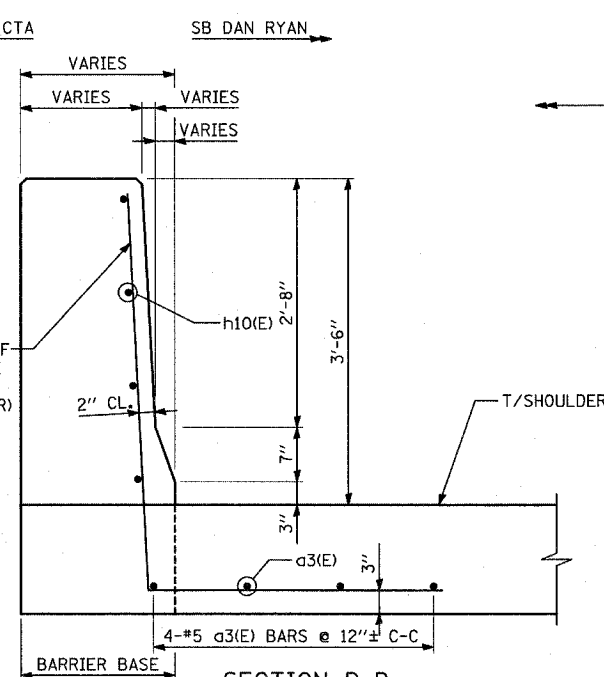

SECTION D-D
15' CONCRETE BARRIER TRANSITION
CONCRETE BARRIER, SINGLE FACE, 42 INCH HEIGHT (SPECIAL)

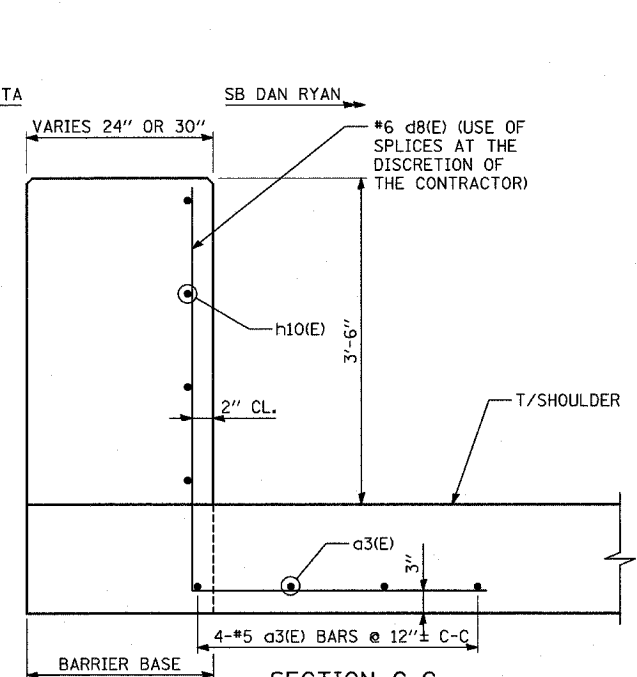

SECTION C-C
15' CONCRETE BARRIER TRANSITION
CONCRETE BARRIER, SINGLE FACE, 42 INCH HEIGHT (SPECIAL)

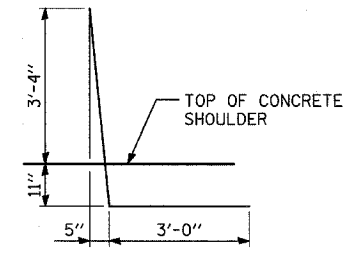

d2(E) BAR

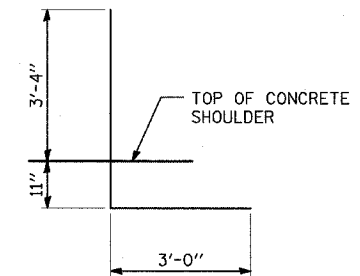

d8(E) BAR

NOTES:

1. BAR SPLICERS SHALL BE CAPABLE OF DEVELOPING A MINIMUM OF 125% OF THE YIELD STRENGTH OF A #6 BAR.
2. ALL REINFORCING BARS, BAR SPLICERS, TIE BARS AND DOWEL BARS SHALL BE SEATED IN THE FINAL POSITION PRIOR TO THE CONCRETE OPERATIONS. BARS CANNOT BE MUCKED INTO PLACE.
3. MAINTAIN SLOPE OF FACE AS SHOWN ON DETAILS.
4. ALL REINFORCING BARS, BAR SPLICERS, TIE BARS AND DOWEL BARS SHALL BE INCLUDED IN THE COST OF "CONCRETE BARRIER, SINGLE FACE" OF THE TYPE SPECIFIED

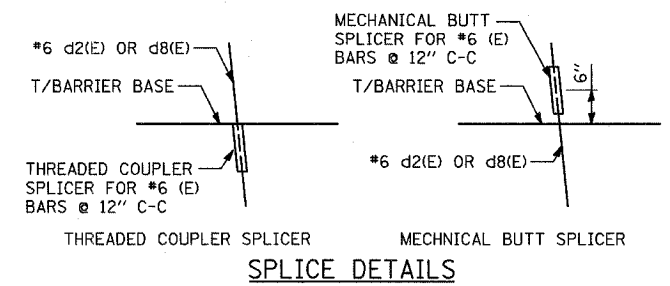

SPlice DETAILS

REVISIONS	
NAME	DATE

ILLINOIS DEPARTMENT OF TRANSPORTATION
F.A.I. 94 (DAN RYAN EXPRESSWAY)

MISCELLANEOUS DETAILS
CONCRETE BARRIER TRANSITION
TYPICAL SECTIONS

SCALE: NONE
DATE: MARCH 1, 2006
DRAWN BY: MFG
CHECKED BY: TGB