

PROPOSED TEMP PAVEMENT MARKINGS AND TRAFFIC CONTROL DEVICES

- (A) TEMP EPOXY PVT MK LINE 4 (SOLID WHITE)
- (B) TEMP EPOXY PVT MK LINE 4 (SOLID YELLOW)
- (C) TEMP EPOXY PVT MK LINE 4 (2' DASH 6' SKIP, WHITE)
- (D) TEMP EPOXY PVT MK LINE 5 (10' DASH 30' SKIP, WHITE)
- (E) TEMP EPOXY PVT MK LINE 8 (SOLID WHITE)
- (F) TEMP EPOXY PVT MK LINE 12 (WHITE CHEVRONS @ 45°, 30" SPACING) (TYP)
- (G) TEMP CONC BARRIER @ 12:1 ON TAPERS UNLESS OTHERWISE NOTED
- (H) IMPACT ATTENUATOR, TEMPORARY, TEST LEVEL 3 (SEE SCHEDULE)
- (I) TYPE II BARRICADE OR DRUMS WITH STEADY BURN MONODIRECTIONAL LIGHT @ 50' C-C (TYP) ON TAPERS AND RAMPS @ 100' C-C (TYP) ON TANGENTS
- (J) DIRECTIONAL INDICATOR BARRICADE WITH STEADY BURN MONODIRECTIONAL LIGHT @ 50' C-C
- (K) REL TEMP CONC BARRIER @ 12:1 ON TAPERS UNLESS OTHERWISE NOTED
- (L) IMPACT ATTENUATOR, RELOCATE (SEE SCHEDULE)
- (M) TEMP EPOXY PVT MK LINE 8 (3' DASH 9' SKIP, WHITE)

LEGEND:

- WORK ZONE
- TEMPORARY CONCRETE BARRIER
- TEMPORARY IMPACT ATTENUATOR
- TEMPORARY SOIL RETENTION SYSTEM OR BRACED EXCAVATION
- DIRECTION OF TRAFFIC FLOW
- TYPE III BARRICADE
- TYPE II BARRICADE OR DRUMS WITH STEADY BURN MONODIRECTIONAL LIGHT
- DIRECTIONAL INDICATOR BARRICADE WITH STEADY BURN MONODIRECTIONAL SIGN
- ARROW BOARD
- REMOVAL LIMITS
- TEMPORARY PAVEMENT

- * FROM PREVIOUS STAGE TO REMAIN
- ** FROM CONTRACT 60X77 TO REMAIN

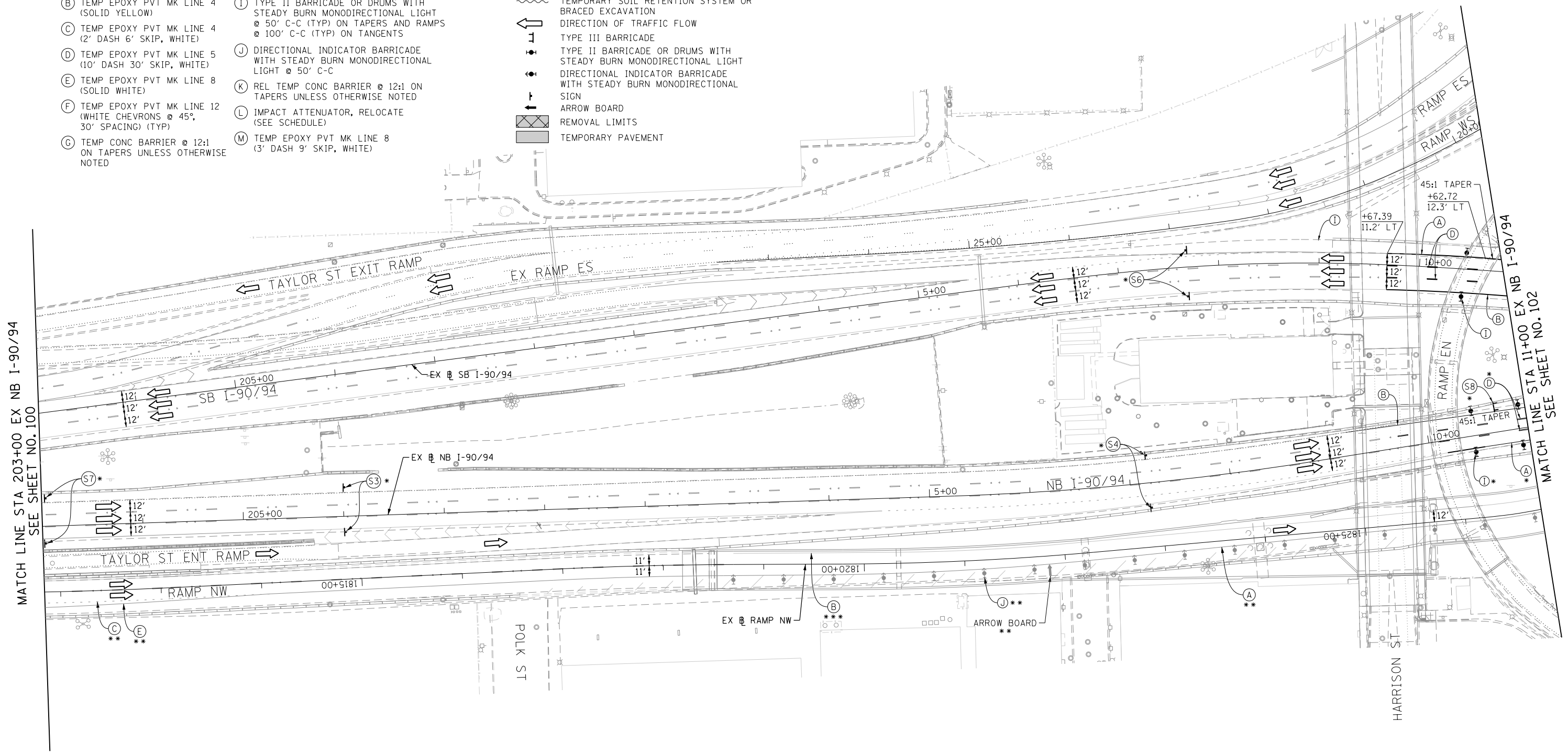

NOTES:

1. ALL NB AND SB I-90/94 LANE CONFIGURATION TO BE MAINTAINED AS PER FINAL LANE CONFIGURATION OF CONTRACTS 60W30.
2. COOPERATION BETWEEN CONTRACTORS WILL BE REQUIRED. SEE TRAFFIC CONTROL GENERAL NOTES FOR DETAIL.

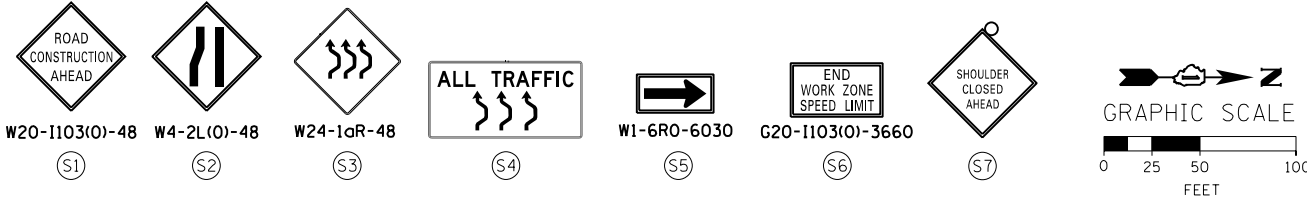

FILE PATH = C:\Users\patelp2\Projects\Circle Interchange\WB-I-290\Printing\2016_0321_60x78-Final_Mot\016078-Sht-Staging-ML-2B-06.dgn



D16078-Sht-Staging-ML-2B-06.dgn	DESIGNED - OPS	REVISED -
USER NAME = patelp2	DRAWN - PHP	REVISED -
PLOT SCALE = 100.0000' / 1"	CHECKED - MC	REVISED -
PLOT DATE = 3/21/2016	DATE - 3/18/2016	REVISED -

**STATE OF ILLINOIS
DEPARTMENT OF TRANSPORTATION**

**SUGGESTED STAGES OF CONSTRUCTION AND TRAFFIC CONTROL PLAN
MAINLINE STAGING 2B**

SCALE: 1" = 50' SHEET 11 OF 15 SHEETS STA. 203+00 TO STA. 11+00

F.A.I. RTE.	SECTION	COUNTY	TOTAL SHEETS	SHEET NO.
90/94/290	2014-004R&B	COOK	706	101
CONTRACT NO. 60X78				
ILLINOIS FED. AID PROJECT				

PROPOSED TEMP PAVEMENT MARKINGS AND TRAFFIC CONTROL DEVICES

- (A) TEMP EPOXY PVT MK LINE 4 (SOLID WHITE)
- (B) TEMP EPOXY PVT MK LINE 4 (SOLID YELLOW)
- (C) TEMP EPOXY PVT MK LINE 4 (2' DASH 6' SKIP, WHITE)
- (D) TEMP EPOXY PVT MK LINE 5 (10' DASH 30' SKIP, WHITE)
- (E) TEMP EPOXY PVT MK LINE 8 (SOLID WHITE)
- (F) TEMP EPOXY PVT MK LINE 12 (WHITE CHEVRONS @ 45°, 30' SPACING) (TYP)
- (G) TEMP CONC BARRIER @ 12:1 ON TAPERS UNLESS OTHERWISE NOTED
- (H) IMPACT ATTENUATOR, TEMPORARY, TEST LEVEL 3 (SEE SCHEDULE)
- (I) TYPE II BARRICADE OR DRUMS WITH STEADY BURN MONODIRECTIONAL LIGHT @ 50' C-C (TYP) ON TAPERS AND RAMP @ 100' C-C (TYP) ON TANGENTS
- (J) DIRECTIONAL INDICATOR BARRICADE WITH STEADY BURN MONODIRECTIONAL LIGHT @ 50' C-C
- (K) REL TEMP CONC BARRIER @ 12:1 ON TAPERS UNLESS OTHERWISE NOTED
- (L) IMPACT ATTENUATOR, RELOCATE (SEE SCHEDULE)
- (M) TEMP EPOXY PVT MK LINE 8 (3' DASH 9' SKIP, WHITE)

LEGEND:

- WORK ZONE
- TEMPORARY CONCRETE BARRIER
- TEMPORARY IMPACT ATTENUATOR
- TEMPORARY SOIL RETENTION SYSTEM OR BRACED EXCAVATION
- DIRECTION OF TRAFFIC FLOW
- TYPE III BARRICADE
- TYPE II BARRICADE OR DRUMS WITH STEADY BURN MONODIRECTIONAL LIGHT
- DIRECTIONAL INDICATOR BARRICADE WITH STEADY BURN MONODIRECTIONAL SIGN
- ARROW BOARD
- REMOVAL LIMITS
- TEMPORARY PAVEMENT

- * FROM PREVIOUS STAGE TO REMAIN
- ** FROM CONTRACT 60X77 TO REMAIN

TRAFFIC CONTROL LAYOUT INFORMATION

POINT		STATION	OFFSET	LT/RT	BASELINE
1	PC	11+97.78	8.4'	LT	E-KDR-SB
2	PRC	16+05.54	10.1'	LT	E-KDR-SB
3		13+00.00	10.0'	LT	E-KDR-SB
4		11+87.94	24.5'	RT	E-KDR-SB
5		13+00.00	27.0'	RT	E-KDR-SB
6		14+20.32	23.3'	LT	E-KDR-SB
7		15+27.40	23.6'	LT	E-KDR-SB

POINT LOCATION

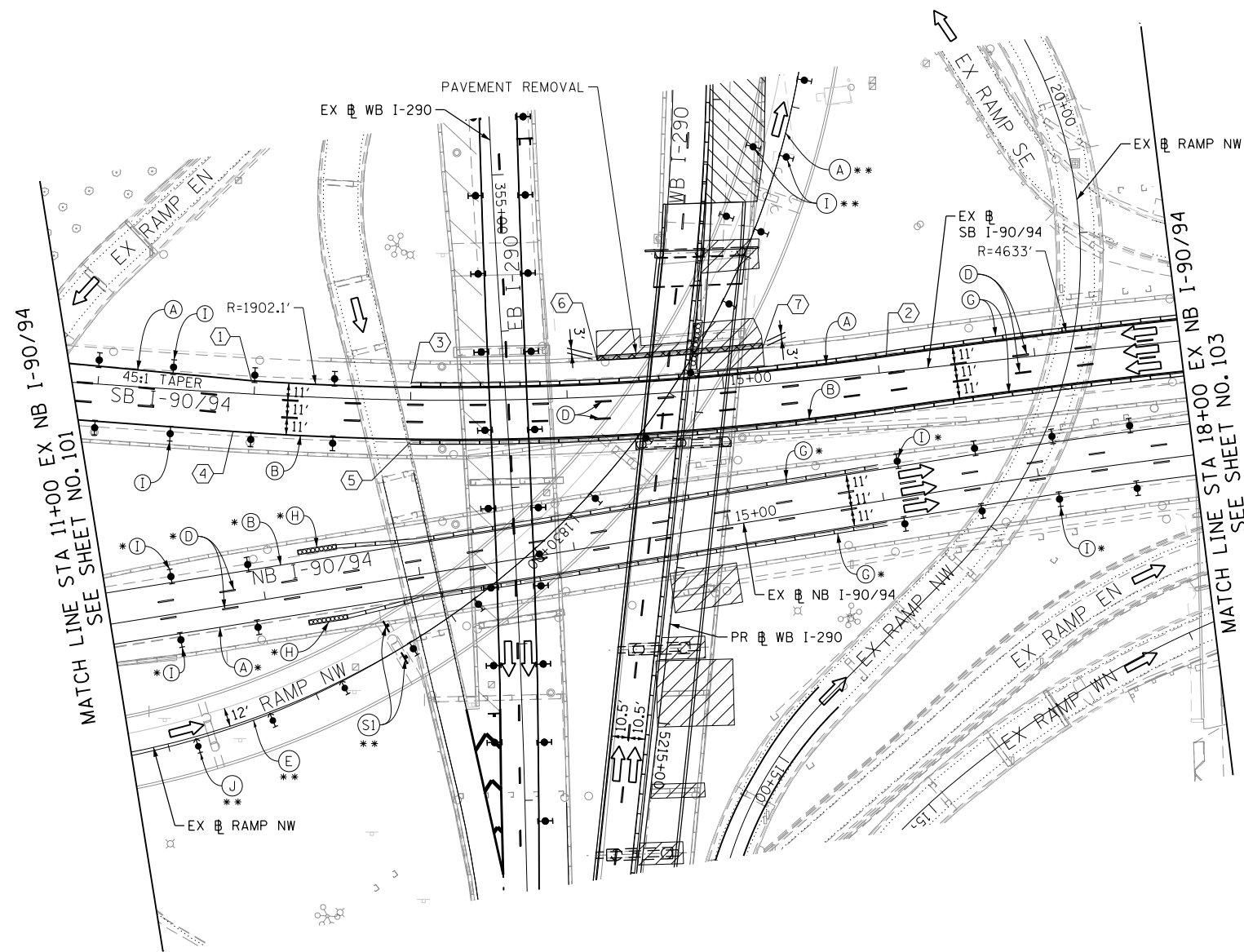

NOTES:

- FOR WB I-290 STAGING DETAILS SEE SHEET NO. 94
- COOPERATION BETWEEN CONTRACTORS WILL BE REQUIRED. SEE TRAFFIC CONTROL GENERAL NOTES FOR DETAIL.

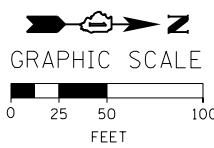

FILE PATH = C:\Users\patelp2\Projects\Circle Interchange\WB-I-290\Printing\2016_0321_00\78-Final_Mot\016078-Sht-Staging-ML-2B-07.dgn



D16078-Sht-Staging-ML-2B-07.dgn
 USER NAME = patelp2
 PLOT SCALE = 100.0000' / 1" / 1" / 1"
 PLOT DATE = 3/21/2016

DESIGNED - OPS	REVISED -
DRAWN - PHP	REVISED -
CHECKED - MC	REVISED -
DATE - 3/18/2016	REVISED -

**STATE OF ILLINOIS
DEPARTMENT OF TRANSPORTATION**

**SUGGESTED STAGES OF CONSTRUCTION AND TRAFFIC CONTROL PLAN
MAINLINE STAGING 2B**
 SCALE: 1" = 50' SHEET 12 OF 15 SHEETS STA. 203+00 TO STA. 11+00

F.A.I. RTE.	SECTION	COUNTY	TOTAL SHEETS	SHEET NO.
90/94/290	2014-004R&B	COOK	706	102
CONTRACT NO. 60X78				
ILLINOIS FED. AID PROJECT				

OH1 EXISTING OVERHEAD SIGNS TO REMAIN

OH2 EXISTING OVERHEAD SIGNS TO REMAIN

OH3 EXISTING OVERHEAD SIGNS TO REMAIN

OH4 EXISTING OVERHEAD SIGN

OH5 EXISTING OVERHEAD SIGN TO REMAIN

NOTES:

- TRAVEL LANE ON RAMP SW BE MAINTAINED IN CURRENT STAGE AS PER CONTRACT 60X77.
- ALL PAVEMENT MARKING AND SIGNINGS ON SB I-90/94, EXIT RAMP SW AND SE SHALL BE COORDINATED ON FIELD WITH CONTRACT 60X77 AND AS PER FIELD ENGINEER.
-
- COOPERATION BETWEEN CONTRACTORS WILL BE REQUIRED. SEE TRAFFIC CONTROL GENERAL NOTES FOR DETAIL.

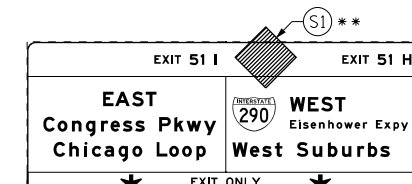
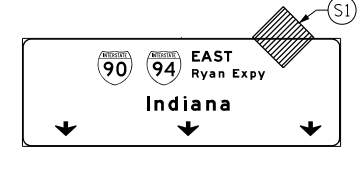
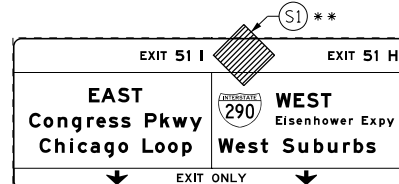
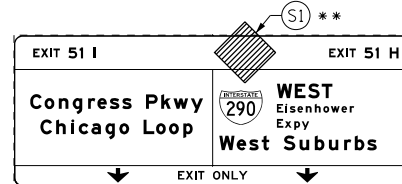
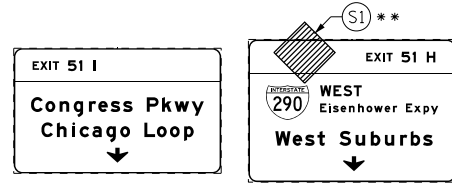

OH6 EXISTING OVERHEAD SIGN

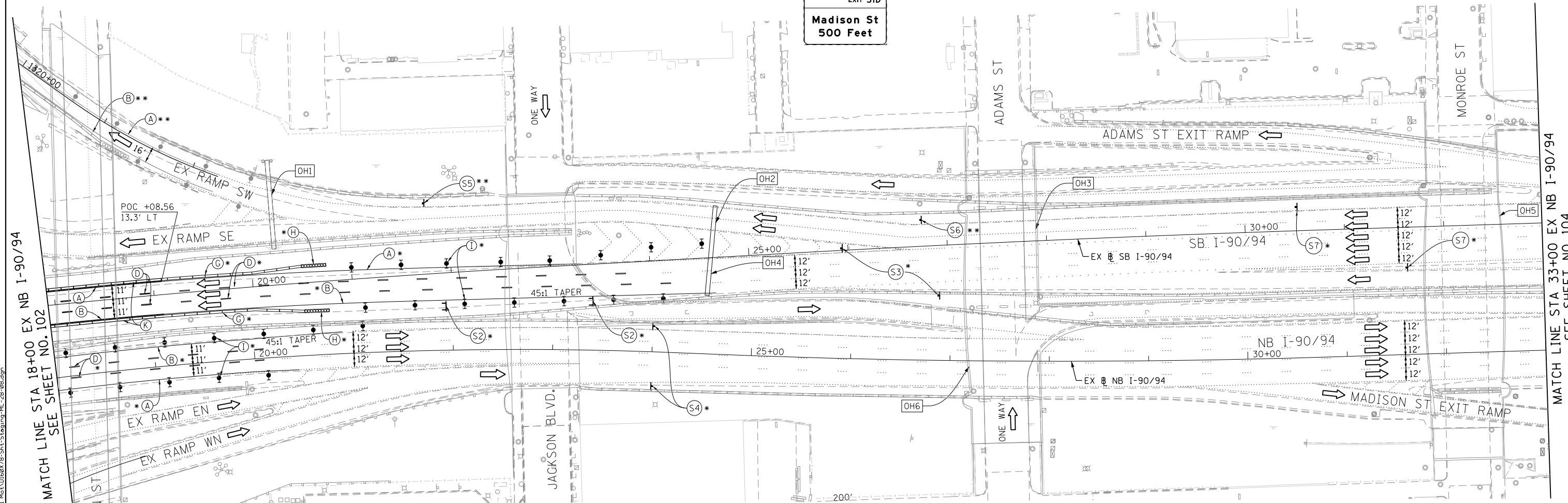

MATCH LINE STA 18+00 EX NB I-90/94 SEE SHEET NO. 102

MATCH LINE STA 33+00 EX NB I-90/94 SEE SHEET NO. 104

PROPOSED TEMP PAVEMENT MARKINGS AND TRAFFIC CONTROL DEVICES

- (A) TEMP EPOXY PVT MK LINE 4 (SOLID WHITE)
 - (B) TEMP EPOXY PVT MK LINE 4 (SOLID YELLOW)
 - (C) TEMP EPOXY PVT MK LINE 4 (2' DASH 6' SKIP, WHITE)
 - (D) TEMP EPOXY PVT MK LINE 5 (10' DASH 30' SKIP, WHITE)
 - (E) TEMP EPOXY PVT MK LINE 8 (SOLID WHITE)
 - (F) TEMP EPOXY PVT MK LINE 12 (WHITE CHEVRONS @ 45°, 30' SPACING) (TYP)
 - (G) TEMP CONC BARRIER @ 12:1 ON TAPERS UNLESS OTHERWISE NOTED
 - (H) IMPACT ATTENUATOR, TEMPORARY, TEST LEVEL 3 (SEE SCHEDULE)
 - (I) TYPE II BARRICADE OR DRUMS WITH STEADY BURN MONODIRECTIONAL LIGHT @ 50' C-C (TYP) ON TAPERS AND RAMP @ 100' C-C (TYP) ON TANGENTS
 - (J) DIRECTIONAL INDICATOR BARRICADE WITH STEADY BURN MONODIRECTIONAL LIGHT @ 50' C-C
 - (K) REL TEMP CONC BARRIER @ 12:1 ON TAPERS UNLESS OTHERWISE NOTED
 - (L) IMPACT ATTENUATOR, RELOCATE (SEE SCHEDULE)
 - (M) TEMP EPOXY PVT MK LINE 8 (3' DASH 9' SKIP, WHITE)
- * FROM PREVIOUS STAGE TO REMAIN
** FROM CONTRACT 60X77 TO REMAIN

- LEGEND:**
- WORK ZONE
 - TEMPORARY CONCRETE BARRIER
 - TEMPORARY IMPACT ATTENUATOR
 - TEMPORARY SOIL RETENTION SYSTEM OR BRACED EXCAVATION
 - DIRECTION OF TRAFFIC FLOW
 - TYPE III BARRICADE
 - TYPE II BARRICADE OR DRUMS WITH STEADY BURN MONODIRECTIONAL LIGHT
 - DIRECTIONAL INDICATOR BARRICADE WITH STEADY BURN MONODIRECTIONAL SIGN
 - ARROW BOARD
 - REMOVAL LIMITS
 - TEMPORARY PAVEMENT

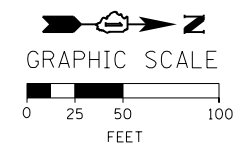
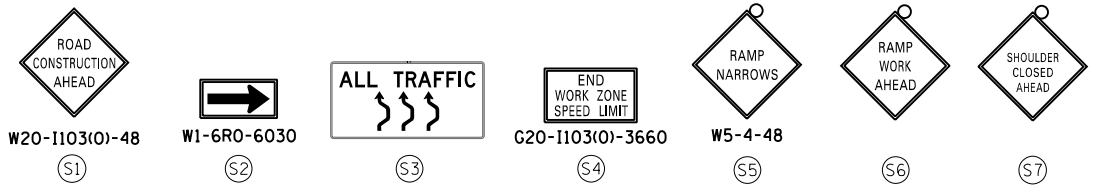

D160X78-Sht-Staging-ML-2B-08.dgn
 USER NAME = patelp2
 PLOT SCALE = 100.0000' / 1" = 100'
 PLOT DATE = 3/21/2016

DESIGNED - OPS	REVISED -
DRAWN - PHP	REVISED -
CHECKED - MC	REVISED -
DATE - 3/18/2016	REVISED -

STATE OF ILLINOIS
 DEPARTMENT OF TRANSPORTATION

SUGGESTED STAGES OF CONSTRUCTION AND TRAFFIC CONTROL PLAN
 MAINLINE STAGING 2B
 SCALE: 1" = 50' SHEET 13 OF 15 SHEETS STA. 18+00 TO STA. 33+00

F.A.I. RTE.	SECTION	COUNTY	TOTAL SHEETS	SHEET NO.
90/94/290	2014-004R&B	COOK	706	103
CONTRACT NO. 60X78				
ILLINOIS FED. AID PROJECT				

FILE PATH = C:\Users\patelp2\Projects\Circles\Interchange\WB-I-290\Printing\2016_0321_08x78-Final_Mot\016078-Sht-Staging-ML-2B-08.dgn

OH1 EXISTING OVERHEAD SIGN

OH2 EXISTING OVERHEAD SIGN

OH3 EXISTING OVERHEAD SIGN

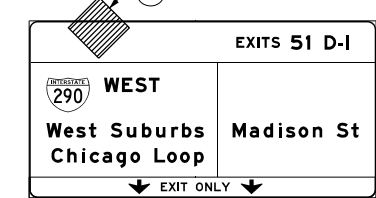
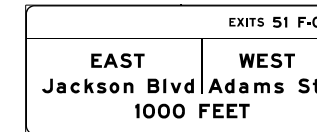
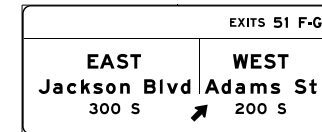

W20-1103(O)-48
S1

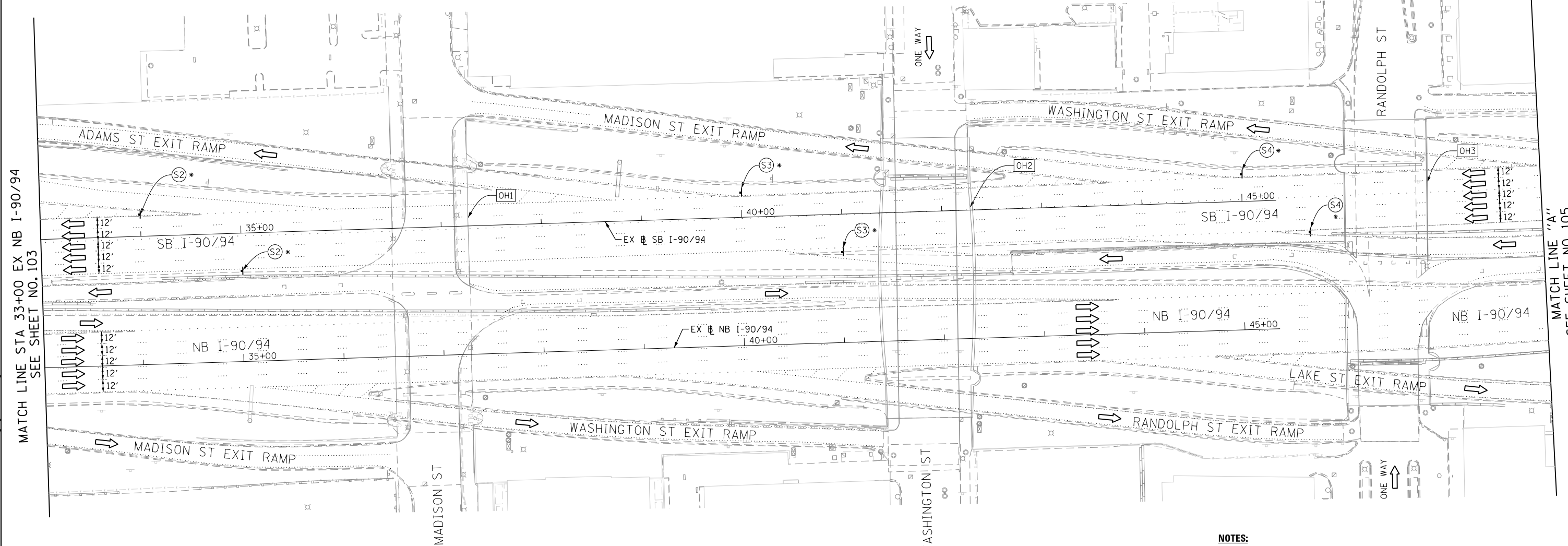

MATCH LINE STA 33+00 EX NB I-90/94
SEE SHEET NO. 103

MATCH LINE "A"
SEE SHEET NO. 105

PROPOSED TEMP PAVEMENT MARKINGS AND TRAFFIC CONTROL DEVICES

- (A) TEMP EPOXY PVT MK LINE 4 (SOLID WHITE)
- (B) TEMP EPOXY PVT MK LINE 4 (SOLID YELLOW)
- (C) TEMP EPOXY PVT MK LINE 4 (2' DASH 6' SKIP, WHITE)
- (D) TEMP EPOXY PVT MK LINE 5 (10' DASH 30' SKIP, WHITE)
- (E) TEMP EPOXY PVT MK LINE 8 (SOLID WHITE)
- (F) TEMP EPOXY PVT MK LINE 12 (WHITE CHEVRONS @ 45°, 30' SPACING) (TYP)
- (G) TEMP CONC BARRIER @ 12:1 ON TAPERS UNLESS OTHERWISE NOTED
- (H) IMPACT ATTENUATOR, TEMPORARY, TEST LEVEL 3 (SEE SCHEDULE)
- (I) TYPE II BARRICADE OR DRUMS WITH STEADY BURN MONODIRECTIONAL LIGHT @ 50' C-C (TYP) ON TAPERS AND RAMP @ 100' C-C (TYP) ON TANGENTS
- (J) DIRECTIONAL INDICATOR BARRICADE WITH STEADY BURN MONODIRECTIONAL LIGHT @ 50' C-C
- (K) REL TEMP CONC BARRIER @ 12:1 ON TAPERS UNLESS OTHERWISE NOTED
- (L) IMPACT ATTENUATOR, RELOCATE (SEE SCHEDULE)
- (M) TEMP EPOXY PVT MK LINE 8 (3' DASH 9' SKIP, WHITE)

LEGEND:

- WORK ZONE
- TEMPORARY CONCRETE BARRIER
- TEMPORARY IMPACT ATTENUATOR
- TEMPORARY SOIL RETENTION SYSTEM OR BRACED EXCAVATION
- DIRECTION OF TRAFFIC FLOW
- TYPE III BARRICADE
- TYPE II BARRICADE OR DRUMS WITH STEADY BURN MONODIRECTIONAL LIGHT
- DIRECTIONAL INDICATOR BARRICADE WITH STEADY BURN MONODIRECTIONAL SIGN
- ARROW BOARD
- REMOVAL LIMITS
- TEMPORARY PAVEMENT

NOTES:

1. ALL SIGNINGS ON SB I-90/94 SHALL BE COORDINATED ON FIELD WITH CONTRACTOR OF CONTRACT 60X77.

* FROM PREVIOUS STAGE TO REMAIN

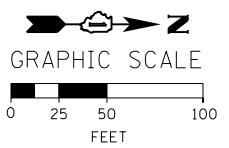
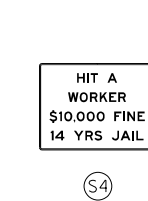
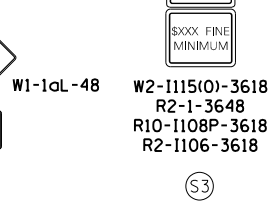
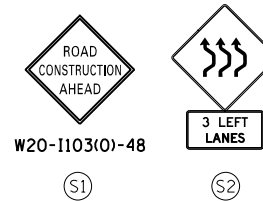
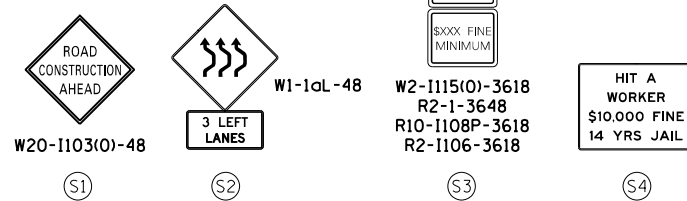

D160X78-Sht-Staging-ML-2B-09.dgn
USER NAME = patelp2
PLOT SCALE = 100.0000' / 1" / 1000
PLOT DATE = 3/21/2016

DESIGNED - OPS	REVISED -
DRAWN - PHP	REVISED -
CHECKED - MC	REVISED -
DATE - 3/18/2016	REVISED -

STATE OF ILLINOIS
DEPARTMENT OF TRANSPORTATION

SUGGESTED STAGES OF CONSTRUCTION AND TRAFFIC CONTROL PLAN
MAINLINE STAGING 2B

SCALE: 1" = 50' SHEET 14 OF 15 SHEETS STA. 33+00 TO STA. "A"

F.A.I. RTE.	SECTION	COUNTY	TOTAL SHEETS	SHEET NO.
90/94/290	2014-004R&B	COOK	706	104
CONTRACT NO. 60X78				
ILLINOIS FED. AID PROJECT				

FILE PATH = C:\Users\patelp2\Projects\Circles Interchange\WB-I-290\Printing\2016-0321-60X78-Final_Mot\016078-Sht-Staging-ML-2B-09.dgn

**PROPOSED TEMP PAVEMENT MARKINGS
AND TRAFFIC CONTROL DEVICES**

- | | |
|---|--|
| (A) TEMP EPOXY PVT MK LINE 4 (SOLID WHITE) | (H) IMPACT ATTENUATOR, TEMPORARY, TEST LEVEL 3 (SEE SCHEDULE) |
| (B) TEMP EPOXY PVT MK LINE 4 (SOLID YELLOW) | (I) TYPE II BARRICADE OR DRUMS WITH STEADY BURN MONODIRECTIONAL LIGHT @ 50' C-C (TYP) ON TAPERS AND RAMPS @ 100' C-C (TYP) ON TANGENTS |
| (C) TEMP EPOXY PVT MK LINE 4 (2' DASH 6' SKIP, WHITE) | (J) DIRECTIONAL INDICATOR BARRICADE WITH STEADY BURN MONODIRECTIONAL LIGHT @ 50' C-C |
| (D) TEMP EPOXY PVT MK LINE 5 (10' DASH 30' SKIP, WHITE) | (K) REL TEMP CONC BARRIER @ 12:1 ON TAPERS UNLESS OTHERWISE NOTED |
| (E) TEMP EPOXY PVT MK LINE 8 (SOLID WHITE) | (L) IMPACT ATTENUATOR, RELOCATE (SEE SCHEDULE) |
| (F) TEMP EPOXY PVT MK LINE 12 (WHITE CHEVRONS @ 45°, 30' SPACING) (TYP) | (M) TEMP EPOXY PVT MK LINE 8 (3' DASH 9' SKIP, WHITE) |
| (G) TEMP CONC BARRIER @ 12:1 ON TAPERS UNLESS OTHERWISE NOTED | |

LEGEND:

- | | |
|--|---|
| | WORK ZONE |
| | TEMPORARY CONCRETE BARRIER |
| | TEMPORARY IMPACT ATTENUATOR |
| | TEMPORARY SOIL RETENTION SYSTEM OR BRACED EXCAVATION |
| | DIRECTION OF TRAFFIC FLOW |
| | TYPE III BARRICADE |
| | TYPE II BARRICADE OR DRUMS WITH STEADY BURN MONODIRECTIONAL LIGHT |
| | DIRECTIONAL INDICATOR BARRICADE WITH STEADY BURN MONODIRECTIONAL SIGN |
| | ARROW BOARD |
| | REMOVAL LIMITS |
| | TEMPORARY PAVEMENT |

* FROM PREVIOUS STAGE TO REMAIN

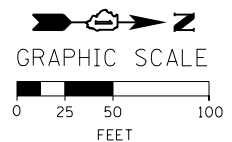
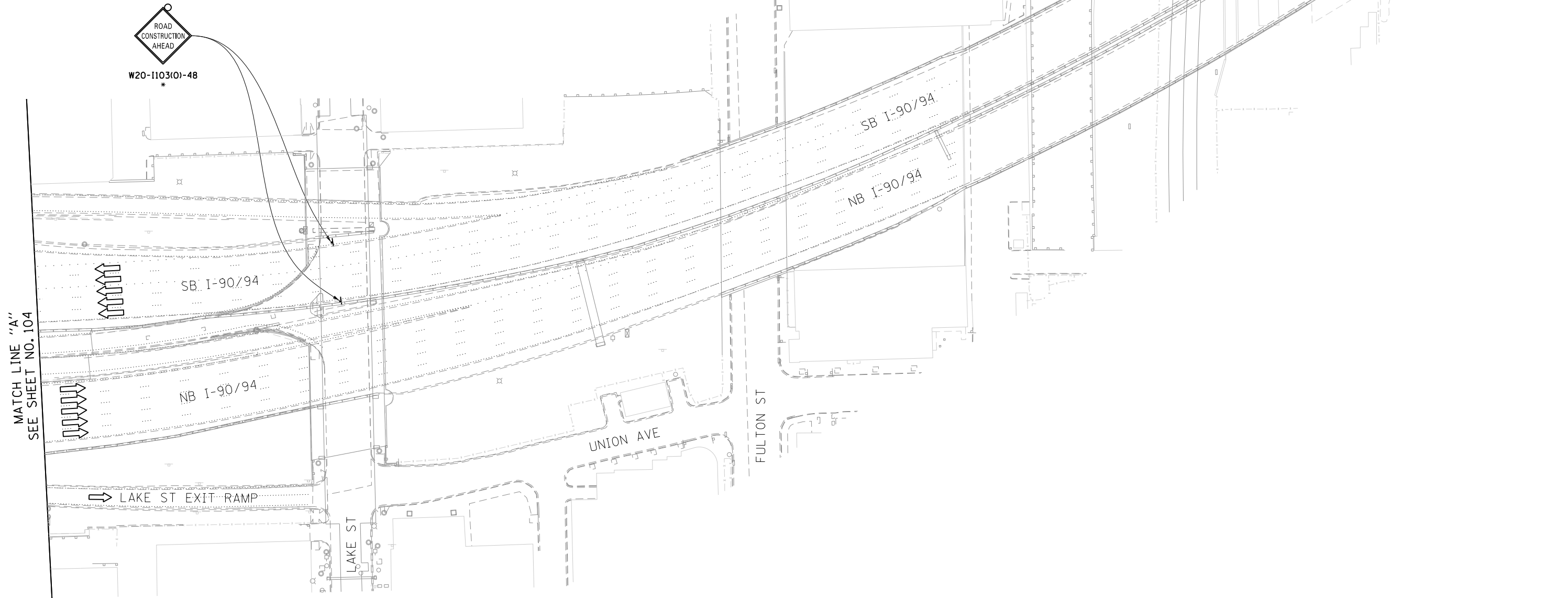

FILE PATH = C:\Users\patelp2\Projects\Circle Interchange\WB-I-290\Printing\2016-03-21 09:28 F.mal Mot\016078-Sht-Staging-ML-2B-10.dgn



D16078-Sht-Staging-ML-2B-10.dgn
USER NAME = patelp2
PLOT SCALE = 100.0000' / 1in.
PLOT DATE = 3/21/2016

DESIGNED - OPS
DRAWN - PHP
CHECKED - MC
DATE - 3/18/2016

REVISED -
REVISED -
REVISED -
REVISED -

STATE OF ILLINOIS
DEPARTMENT OF TRANSPORTATION

SUGGESTED STAGES OF CONSTRUCTION AND TRAFFIC CONTROL PLAN
MAINLINE STAGING 2B

SCALE: 1" = 50' SHEET 15 OF 15 SHEETS STA. 173+00 TO STA. 188+00

F.A.I. RTE.	SECTION	COUNTY	TOTAL SHEETS	SHEET NO.
90/94/290	2014-004R&B	COOK	706	105
CONTRACT NO. 60X78				
ILLINOIS FED. AID PROJECT				

FILE PATH = p:\161749-PMINT\pccommon\local\AECOM\0502_MIA\Documents\01_Americas\Tran\engp\station\60269938_Circle\Phase_11\000_CAD\006_Roadway\Sheets\60x78_Contract\0160x78-sht-Staging-LOCAL-1-01



CUSTOM SIGN
BLACK LETTERS ON
ORANGE BACKGROUND
48" x 48"



R11-1102-2430



(SEE CDOT STD DETAILS)

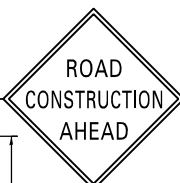

G20-2 36"x18"



R11-1101-2418



R11-1102-2430

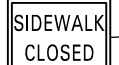

R11-1101-2418

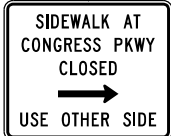

CUSTOM SPECIAL
BLACK LETTERS ON ORANGE BACKGROUND
36" x 30"

SIGN SHALL BE PLACED AT
THE NORTHWEST CORNER OF
DES PLAINES AND HARRISON
STREET.

PROPOSED TEMP PAVEMENT MARKINGS

- (A) TEMP EPOXY PVT MK LINE 4 (SOLID WHITE)
- (B) TEMP EPOXY PVT MK LINE 4 (SOLID YELLOW)
- (C) TEMP EPOXY PVT MK LINE 4 (2' DASH 6' SKIP, WHITE)

NOTES:

1. FOR TRAFFIC CONTROL AND CONSTRUCTION STAGING ON WB CONGRESS PARKWAY, SEE MAINLINE STAGING PLANS.
2. THE CONTRACTOR SHALL MAINTAIN CONTINUOUS ACCESS TO ALL SIDE STREETS, ALLEYS, DRIVEWAY ENTRANCES AND PARKING LOTS AT ALL TIMES.
3. THE CONTRACTOR SHALL COORDINATE ALL ON-STREET PARKING WITH THE CITY OF CHICAGO PRIOR TO ANY CLOSURES. SEE LOCAL STREET IMPACTS SPECIAL PROVISION.
4. MAINTAIN CHICAGO MEGABUS CLINTON STREET TERMINAL AT ALL TIMES. COORDINATION WITH MEGABUS USA, LLC IS REQUIRED.
5. RESTRICTIONS ON EB CONGRESS PARKWAY AND TILDEN STREET WEST OF CLINTON STREET SHALL ONLY BE IN PLACE TO INSTALL TEMPORARY ROADWAY LIGHTING AND TO PERFORM PATCHING. SEE ROADWAY DETAILS AND PROPOSED LIGHTING PLANS.

NOTES (CONTINUED):

6. SIDEWALK CLOSURE ON JEFFERSON STREET SHALL ONLY BE USED DURING ITS INFRASTRUCTURE INSTALLATION AND AS NEEDED DURING PIER REPAIRS.

LEGEND:

- WORK ZONE
- TEMPORARY CONCRETE BARRIER AND TEMP CL FENCE SCR N 4
- TEMPORARY CONCRETE BARRIER
- TEMPORARY IMPACT ATTENUATOR
- DRIVEWAY/ALLEY ENTRANCE (TO REMAIN OPEN AT ALL TIMES)
- DIRECTION OF TRAFFIC FLOW
- CONE, DRUM OR BARRICADE
- TYPE II BARRICADE OR DRUMS WITH STEADY BURN MONODIRECTIONAL LIGHT
- TYPE III BARRICADE
- SIGN
- ARROW BOARD

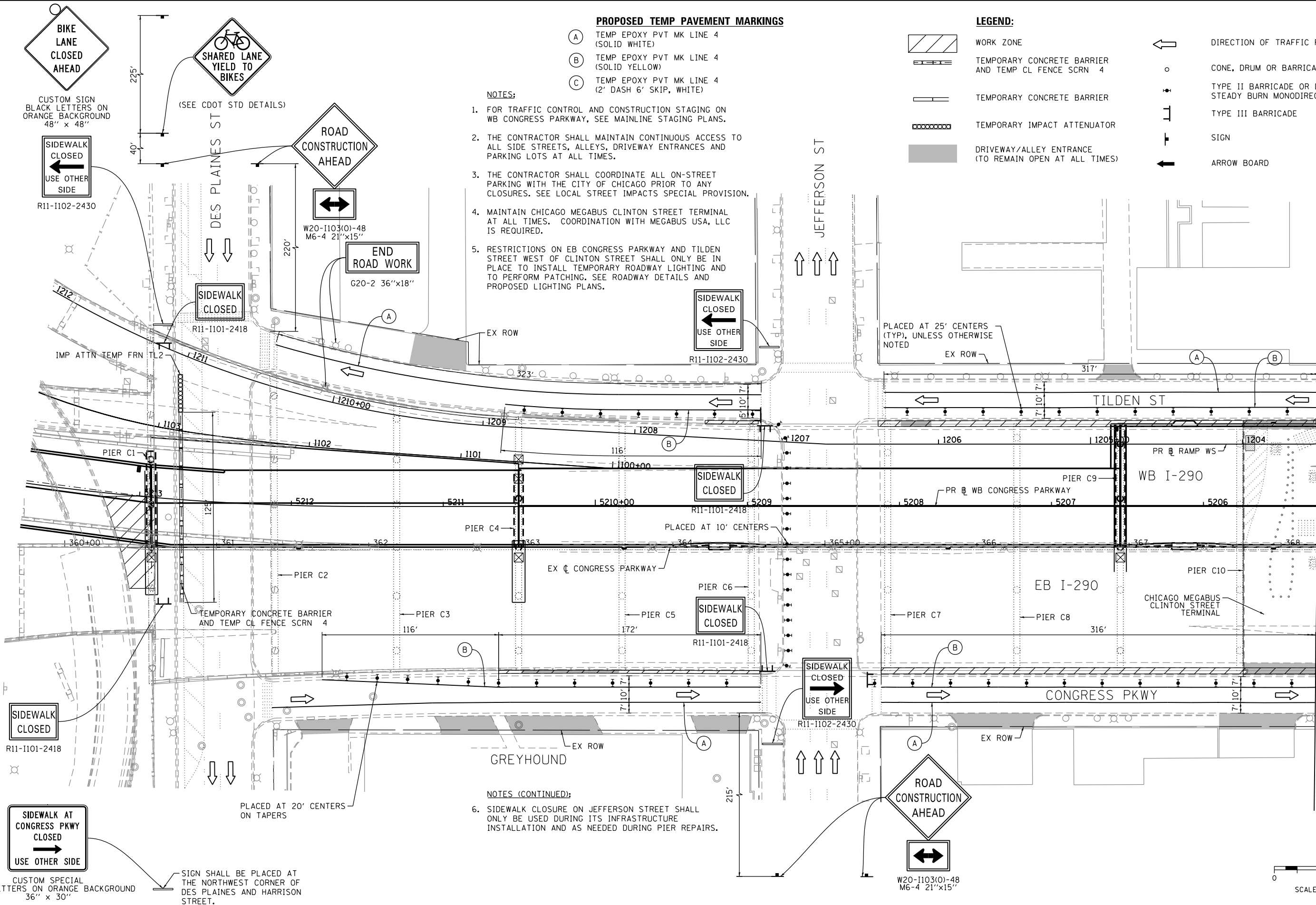

MATCH LINE STA 5205+25
(PR & WB CONGRESS PARKWAY)
SEE SHEET NO. 107

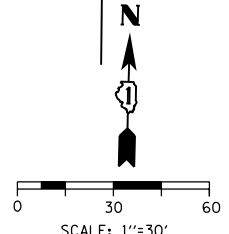

D160x78-sht-Staging-LOCAL-1-01
USER NAME = dshevoz
PLOT SCALE = 60.0000' / in.
PLOT DATE = 4/27/2016

DESIGNED - AFC	REVISED -
DRAWN - AFC	REVISED -
CHECKED - MSC	REVISED -
DATE - 3/18/2016	REVISED -









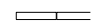
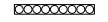

**STATE OF ILLINOIS
DEPARTMENT OF TRANSPORTATION**

**SUGGESTED STAGES OF CONSTRUCTION AND TRAFFIC CONTROL PLAN
LOCAL ROAD - STAGING 1**

SCALE: 1" = 30' SHEET 1 OF 2 SHEETS STA. TO STA.

F.A.I. RTE.	SECTION	COUNTY	TOTAL SHEETS	SHEET NO.
90/94/290	2014-004R&B	COOK	706	106
CONTRACT NO. 60X78				
ILLINOIS FED. AID PROJECT				

LEGEND:

-  WORK ZONE
-  TEMPORARY CONCRETE BARRIER AND TEMP CL FENCE SCR N 4
-  TEMPORARY CONCRETE BARRIER
-  TEMPORARY IMPACT ATTENUATOR
-  DRIVEWAY/ALLEY ENTRANCE (TO REMAIN OPEN AT ALL TIMES)
-  DIRECTION OF TRAFFIC FLOW
-  CONE, DRUM OR BARRICADE
-  BARRICADE OR DRUM WITH FLASHING LIGHT
-  TYPE III BARRICADE
-  SIGN
-  ARROW BOARD

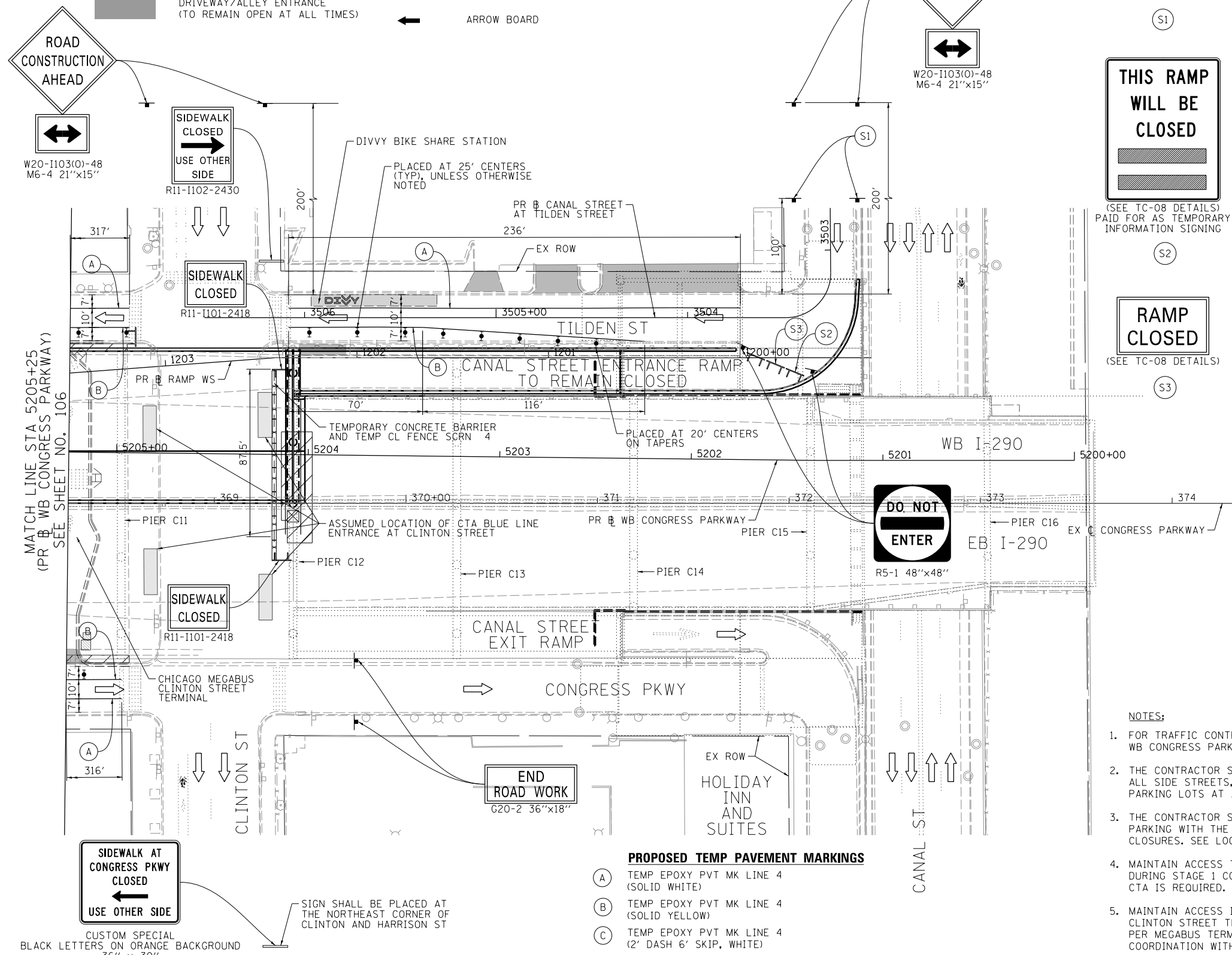

SIGN DETAIL

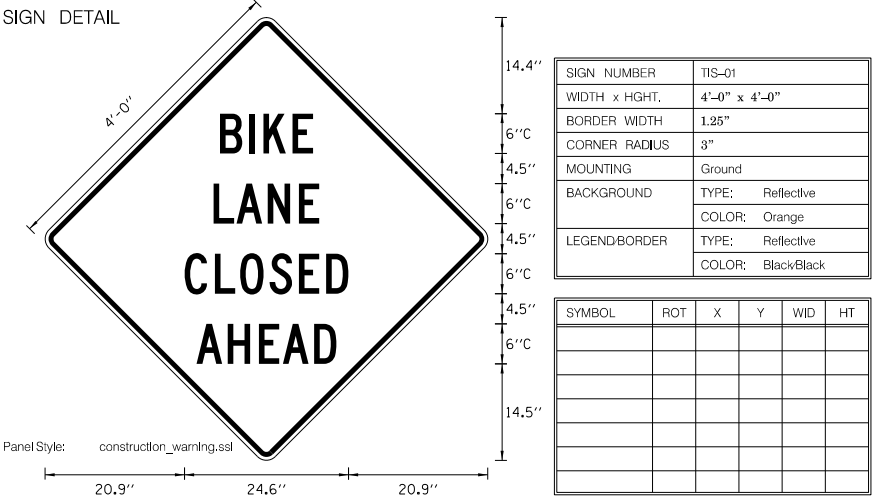

LETTER POSITIONS (X)

	B	I	K	E						LENGTH	SERIESIZE
	26.2	30.6	32.8	37.2						14	6
	25.3	28.7	33.4	38.1						15.9	6
	20.9	25.5	29.3	33.7	38.1	42.2				24.6	6
	22.7	27.4	32.1	35.7	40.4					21	6

SIGN DETAIL

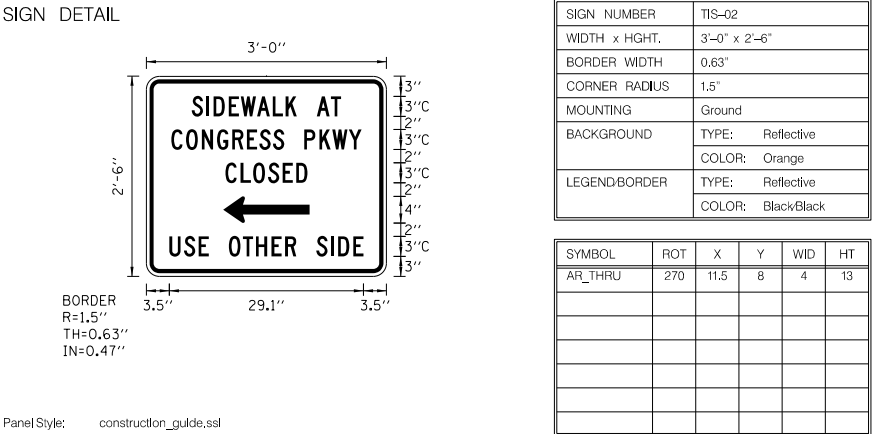

LETTER POSITIONS (X)

	S	I	D	E	W	A	L	K	A	T						LENGTH	SERIESIZE
	6.8	9	10.1	12.4	14.2	16.6	19	20.9	22.6	25.6	27.7					22.4	3
	3.7	6	8.3	10.6	12.9	15.1	17	19	20.7	23.7	26	27.9	30.4			28.6	3
	11.9	14.1	16	18.3	20.4	22.5										12.3	3
	3.5	5.6	7.8	9.4	12.4	14.5	16.4	18.8	20.8	22.5	25.5	27.7	28.8	31.1		29.1	3

NOTES:

- FOR TRAFFIC CONTROL AND CONSTRUCTION STAGING ON WB CONGRESS PARKWAY, SEE MAINLINE STAGING PLANS.
- THE CONTRACTOR SHALL MAINTAIN CONTINUOUS ACCESS TO ALL SIDE STREETS, ALLEYS, DRIVEWAY ENTRANCES AND PARKING LOTS AT ALL TIMES.
- THE CONTRACTOR SHALL COORDINATE ALL ON-STREET PARKING WITH THE CITY OF CHICAGO PRIOR TO ANY CLOSURES. SEE LOCAL STREET IMPACTS SPECIAL PROVISION.
- MAINTAIN ACCESS TO THE CTA ENTRANCES AT ALL TIMES DURING STAGE 1 CONSTRUCTION. COORDINATION WITH THE CTA IS REQUIRED.
- MAINTAIN ACCESS INTO AND OUT OF CHICAGO MEGABUS CLINTON STREET TERMINAL AT ALL TIMES UNLESS COORDINATED PER MEGABUS TERMINAL COORDINATION SPECIAL PROVISION. COORDINATION WITH MEGABUS USA, LLC IS REQUIRED.
- MAINTAIN DIVVY BIKE SHARE STATION AT ALL TIMES. COORDINATION WITH CITY OF CHICAGO IS REQUIRED.
- SEE DETOUR PLAN FOR THE CANAL STREET ENTRANCE RAMP CLOSURE.
- RESTRICTIONS ON EB CONGRESS PARKWAY AND TILDEN STREET WEST OF CLINTON STREET SHALL ONLY BE IN PLACE TO INSTALL TEMPORARY ROADWAY LIGHTING AND TO PERFORM PATCHING. SEE ROADWAY DETAILS AND PROPOSED LIGHTING PLANS.

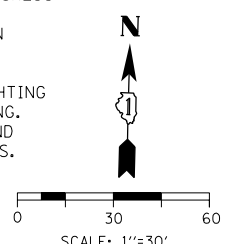

PROPOSED TEMP PAVEMENT MARKINGS

- (A) TEMP EPOXY PVT MK LINE 4 (SOLID WHITE)
- (B) TEMP EPOXY PVT MK LINE 4 (SOLID YELLOW)
- (C) TEMP EPOXY PVT MK LINE 4 (2' DASH 6' SKIP, WHITE)



D16078-sht-Staging-LOCAL-1-02.dgn	DESIGNED - AFC	REVISED -
USER NAME = chiue	DRAWN - AFC	REVISED -
PLOT SCALE = 60.0000' / in.	CHECKED - MSC	REVISED -
PLOT DATE = 3/20/2016	DATE - 3/18/2016	REVISED -

**STATE OF ILLINOIS
DEPARTMENT OF TRANSPORTATION**

**SUGGESTED STAGES OF CONSTRUCTION AND TRAFFIC CONTROL PLAN
LOCAL ROAD - STAGING 1**

SCALE: 1" = 30' SHEET 2 OF 2 SHEETS STA. TO STA.

F.A.I. RTE.	SECTION	COUNTY	TOTAL SHEETS	SHEET NO.
90/94/290	2014-004R&B	COOK	706	107
CONTRACT NO. 60X78				
ILLINOIS FED. AID PROJECT				

FILE PATH = P:\60288727\000_CAD\006_Roadway\Printing\6078\2016-03-18_F.mpl_Plot_Export\D16078-sht-Staging-LOCAL-1-02.dgn

PROPOSED TEMP PAVEMENT MARKINGS

- (A) TEMP EPOXY PVT MK LINE 4 (SOLID WHITE)
- (B) TEMP EPOXY PVT MK LINE 4 (SOLID YELLOW)
- (C) TEMP EPOXY PVT MK LINE 4 (2' DASH 6' SKIP, WHITE)

LEGEND:

- WORK ZONE
- TEMPORARY CONCRETE BARRIER AND TEMP CL FENCE SCR N 4
- TEMPORARY CONCRETE BARRIER
- TEMPORARY IMPACT ATTENUATOR
- DRIVEWAY/ALLEY ENTRANCE (TO REMAIN OPEN AT ALL TIMES)
- DIRECTION OF TRAFFIC FLOW
- CONE, DRUM OR BARRICADE
- TYPE II BARRICADE OR DRUMS WITH STEADY BURN MONODIRECTIONAL LIGHT
- TYPE III BARRICADE
- SIGN
- ARROW BOARD

* FROM PREVIOUS STAGE TO REMAIN

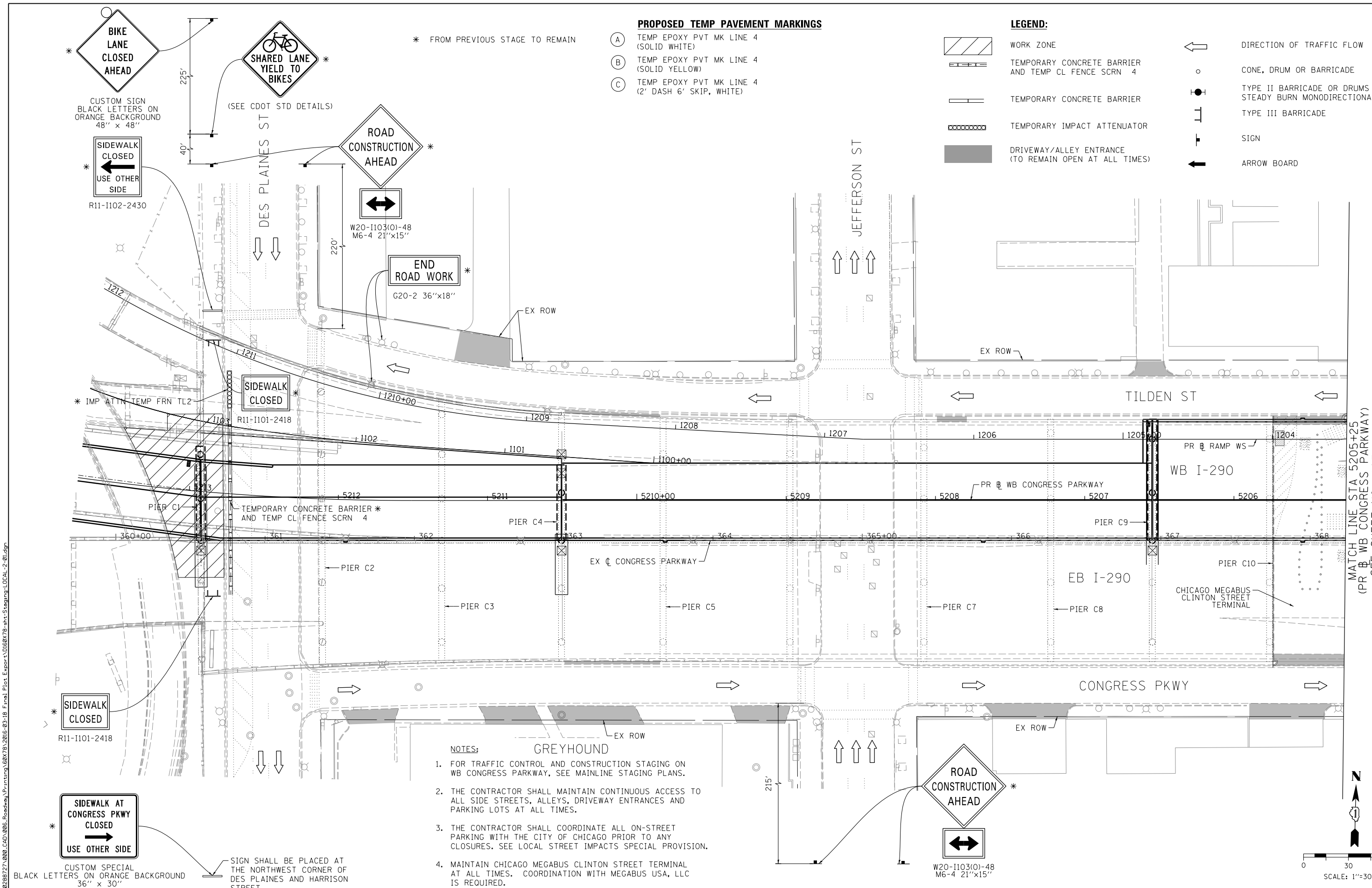

- NOTES:**
- FOR TRAFFIC CONTROL AND CONSTRUCTION STAGING ON WB CONGRESS PARKWAY, SEE MAINLINE STAGING PLANS.
 - THE CONTRACTOR SHALL MAINTAIN CONTINUOUS ACCESS TO ALL SIDE STREETS, ALLEYS, DRIVEWAY ENTRANCES AND PARKING LOTS AT ALL TIMES.
 - THE CONTRACTOR SHALL COORDINATE ALL ON-STREET PARKING WITH THE CITY OF CHICAGO PRIOR TO ANY CLOSURES. SEE LOCAL STREET IMPACTS SPECIAL PROVISION.
 - MAINTAIN CHICAGO MEGABUS CLINTON STREET TERMINAL AT ALL TIMES. COORDINATION WITH MEGABUS USA, LLC IS REQUIRED.

MATCH LINE STA 5205+25 (PR WB CONGRESS PARKWAY) SEE SHEET NO. 107



D160X78-sht-Staging-LOCAL-2-01.dgn
 USER NAME = chiuw
 PLOT SCALE = 60.0000' / in.
 PLOT DATE = 3/20/2016

DESIGNED - AFC	REVISED -
DRAWN - AFC	REVISED -
CHECKED - MSC	REVISED -
DATE - 3/18/2016	REVISED -

**STATE OF ILLINOIS
 DEPARTMENT OF TRANSPORTATION**









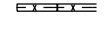

**SUGGESTED STAGES OF CONSTRUCTION AND TRAFFIC CONTROL PLAN
 LOCAL ROAD - STAGING 2A AND 2B**

SCALE: 1" = 30' SHEET 1 OF 2 SHEETS STA. TO STA.

F.A.I. RTE.	SECTION	COUNTY	TOTAL SHEETS	SHEET NO.
90/94/290	2014-004R&B	COOK	706	108
CONTRACT NO. 60X78				
ILLINOIS FED. AID PROJECT				

FILE PATH = P:\60288727\000_CAD\006_Roadway\Printing\60X78_2016_03-18_F.mpl_Plot_Export\160X78-sht-Staging-LOCAL-2-01.dgn

LEGEND:

-  WORK ZONE
-  TEMPORARY CONCRETE BARRIER AND TEMP CL FENCE SCR N 4
-  TEMPORARY CONCRETE BARRIER
-  TEMPORARY IMPACT ATTENUATOR
-  DRIVEWAY/ALLEY ENTRANCE (TO REMAIN OPEN AT ALL TIMES)
-  DIRECTION OF TRAFFIC FLOW
-  CONE, DRUM OR BARRICADE
-  BARRICADE OR DRUM WITH FLASHING LIGHT
-  TYPE III BARRICADE
-  SIGN
-  ARROW BOARD

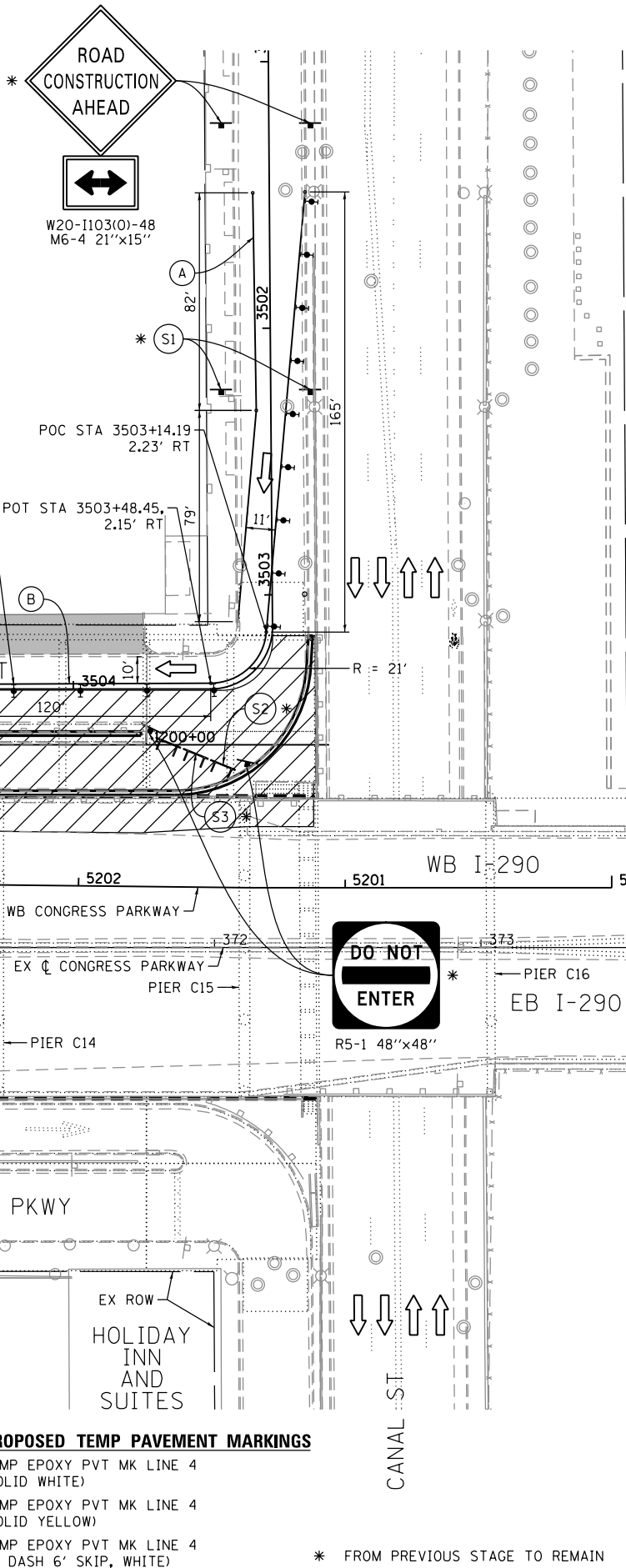

SIGN DETAIL

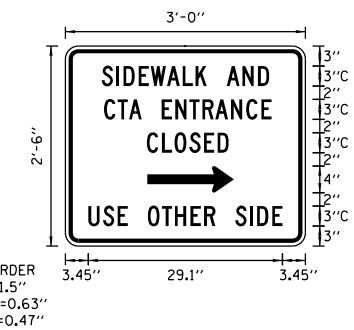

SIGN NUMBER	TIS-03
WIDTH x HGHT.	3'-0" x 2'-6"
BORDER WIDTH	0.63"
CORNER RADIUS	1.5"
MOUNTING	Ground
BACKGROUND	TYPE: Reflective
	COLOR: Orange
LEGEND/BORDER	TYPE: Reflective
	COLOR: Black/Black

SYMBOL	ROT	X	Y	WID	HT
AR_THRU	270	12.3	8	4	13

LETTER POSITIONS (X)											LENGTH	SERIES/SIZE	
S	I	D	E	W	A	L	K	A	N	D		C	2000
5.5	7.6	8.7	11	12.8	15.3	17.6	19.6	21.2	24.2	26.6	28.9		25.1 3
C	T	A	E	N	T	R	A	N	C	E		C	2000
5.8	7.8	9.5	11.5	14.5	16.5	18.6	20.6	22.5	24.8	27.1	29.4		25.2 3
C	L	O	S	E	D							C	2000
12.2	14.5	16.4	18.6	20.8	22.8								12.3 3
U	S	E	O	T	H	E	R	S	I	D	E	C	2000
3.5	5.6	7.8	9.4	12.4	14.5	16.4	18.8	20.8	22.5	25.5	27.7	28.8	31.1 29.1 3

THIS RAMP WILL BE CLOSED

(SEE TC-08 DETAILS) PAID FOR AS TEMPORARY INFORMATION SIGNING

RAMP CLOSED

(SEE TC-08 DETAILS)

NOTES:

- FOR TRAFFIC CONTROL AND CONSTRUCTION STAGING ON WB CONGRESS PARKWAY, SEE MAINLINE STAGING PLANS.
- THE CONTRACTOR SHALL MAINTAIN CONTINUOUS ACCESS TO ALL SIDE STREETS, ALLEYS, DRIVEWAY ENTRANCES AND PARKING LOTS AT ALL TIMES.
- BRIDGE DECK SCARIFICATION AND LATEX CONCRETE OVERLAY WORK SHALL BE PERFORMED IN STAGES TO ALLOW CONTINUOUS ACCESS TO THE ENTRANCE AND GARAGE OF 525 WEST VAN BUREN STREET.
- THE CONTRACTOR SHALL COORDINATE ALL ON-STREET PARKING WITH THE CITY OF CHICAGO PRIOR TO ANY CLOSURES. SEE LOCAL STREET IMPACTS SPECIAL PROVISION.
- MAINTAIN ACCESS TO THE CTA ENTRANCES EXCEPT AT THE NORTHEAST ENTRANCE TO THE CLINTON STREET STATION AT ALL TIMES DURING STAGE 2 CONSTRUCTION. COORDINATION WITH THE CTA IS REQUIRED.
- MAINTAIN ACCESS INTO AND OUT OF CHICAGO MEGABUS CLINTON STREET TERMINAL AT ALL TIMES UNLESS COORDINATED PER MEGABUS TERMINAL COORDINATION SPECIAL PROVISION. COORDINATION WITH MEGABUS USA, LLC IS REQUIRED.
- MAINTAIN DIVVY BIKE SHARE STATION AT ALL TIMES. COORDINATION WITH CITY OF CHICAGO IS REQUIRED.
- SEE DETOUR PLAN FOR THE CANAL STREET ENTRANCE RAMP CLOSURE.

PROPOSED TEMP PAVEMENT MARKINGS

- (A) TEMP EPOXY PVT MK LINE 4 (SOLID WHITE)
- (B) TEMP EPOXY PVT MK LINE 4 (SOLID YELLOW)
- (C) TEMP EPOXY PVT MK LINE 4 (2' DASH 6' SKIP, WHITE)

* FROM PREVIOUS STAGE TO REMAIN



D16078-sht-Staging-LOCAL-2-02	DESIGNED - AFC	REVISED -
USER NAME = chiue	DRAWN - AFC	REVISED -
PLOT SCALE = 60.0000' / in.	CHECKED - MSC	REVISED -
PLOT DATE = 3/21/2016	DATE - 3/18/2016	REVISED -

**STATE OF ILLINOIS
DEPARTMENT OF TRANSPORTATION**









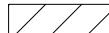

**SUGGESTED STAGES OF CONSTRUCTION AND TRAFFIC CONTROL PLAN
LOCAL ROAD - STAGING 2A AND 2B**

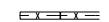
SCALE: 1" = 30' SHEET 2 OF 2 SHEETS STA. TO STA.

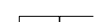

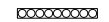

F.A.I. RTE.	SECTION	COUNTY	TOTAL SHEETS	SHEET NO.
90/94/290	2014-004R&B	COOK	706	109
CONTRACT NO. 60X78				
ILLINOIS FED. AID PROJECT				

FILE PATH = p:\6179-PMINT\pccom\line\local\AECOM_D902_MIA\Documents\01_Americas\T\engor\station\60269938_Circle\Phase_11\000_CAD\006_Roadway\Sheets\60X78_Contract\016078-sht-Staging-LOCAL-2-02

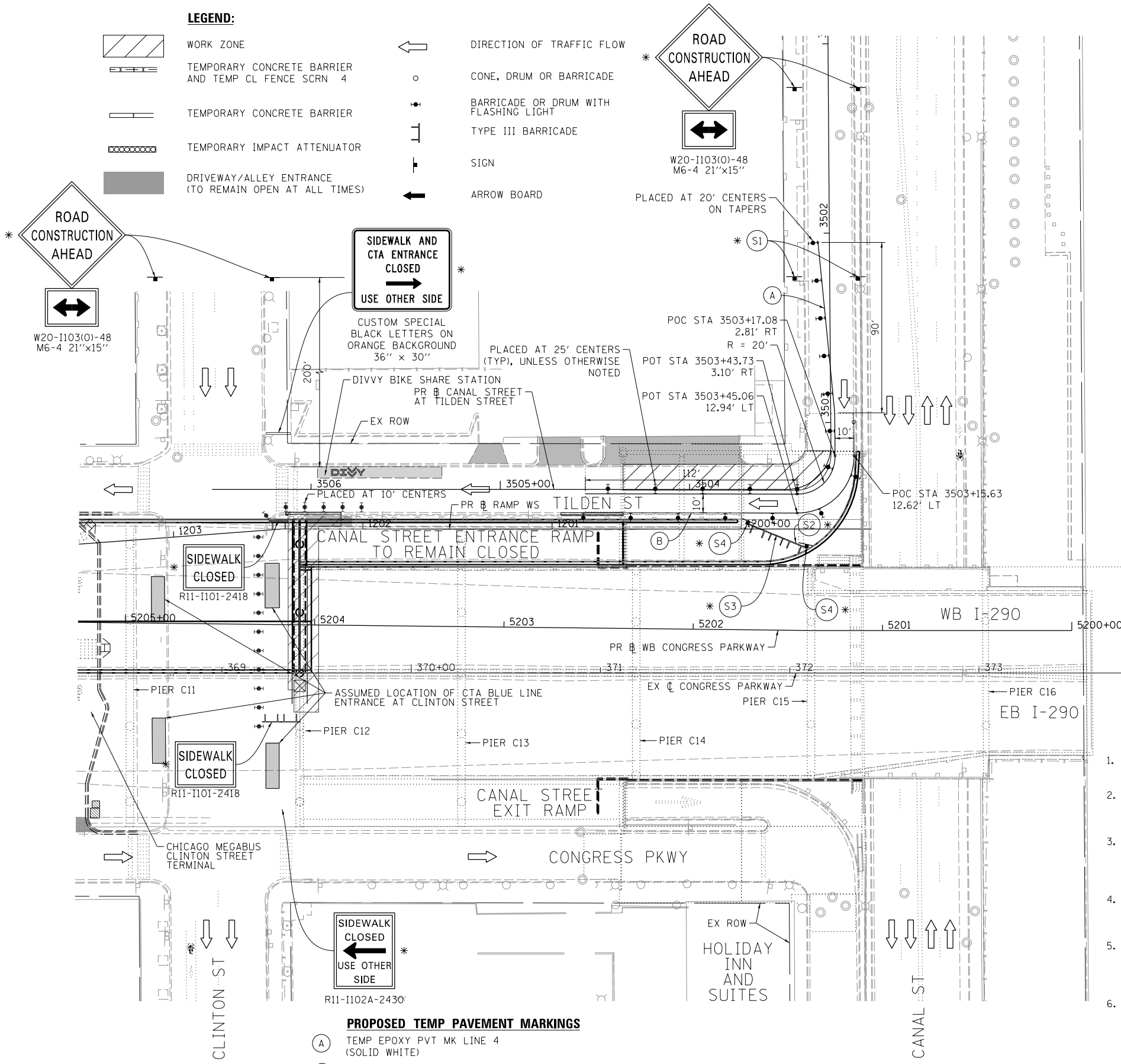
LEGEND:

- | | | | |
|---|---|---|---------------------------------------|
|  | WORK ZONE |  | DIRECTION OF TRAFFIC FLOW |
|  | TEMPORARY CONCRETE BARRIER AND TEMP CL FENCE SCR N 4 |  | CONE, DRUM OR BARRICADE |
|  | TEMPORARY CONCRETE BARRIER |  | BARRICADE OR DRUM WITH FLASHING LIGHT |
|  | TEMPORARY IMPACT ATTENUATOR |  | TYPE III BARRICADE |
|  | DRIVEWAY/ALLEY ENTRANCE (TO REMAIN OPEN AT ALL TIMES) |  | SIGN |
| | |  | ARROW BOARD |

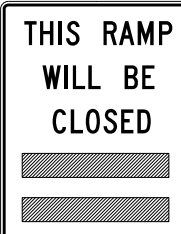

- 
W20-1103(O)-48
M6-4 21"x15"
PLACED AT 20' CENTERS ON TAPERS
- 
W20-30-48
(S1)
- 
(SEE TC-08 DETAILS) PAID FOR AS TEMPORARY INFORMATION SIGNING
(S2)
- 
(SEE TC-08 DETAILS)
(S3)
- 
R5-1 48"x48"
(S4)

NOTES:

1. FOR TRAFFIC CONTROL AND CONSTRUCTION STAGING ON WB CONGRESS PARKWAY, SEE MAINLINE STAGING PLANS.
2. THE CONTRACTOR SHALL MAINTAIN CONTINUOUS ACCESS TO ALL SIDE STREETS, ALLEYS, DRIVEWAY ENTRANCES AND PARKING LOTS AT ALL TIMES.
3. BRIDGE DECK SCARIFICATION AND LATEX CONCRETE OVERLAY WORK SHALL BE PERFORMED IN STAGES TO ALLOW CONTINUOUS ACCESS TO THE ENTRANCE AND GARAGE OF 525 WEST VAN BUREN STREET.
4. THE CONTRACTOR SHALL COORDINATE ALL ON-STREET PARKING WITH THE CITY OF CHICAGO PRIOR TO ANY CLOSURES. SEE LOCAL STREET IMPACTS SPECIAL PROVISION.
5. MAINTAIN ACCESS TO THE CTA ENTRANCES EXCEPT AT THE NORTHEAST ENTRANCE TO THE CLINTON STREET STATION AT ALL TIMES DURING STAGE 2 CONSTRUCTION. COORDINATION WITH THE CTA IS REQUIRED.
6. MAINTAIN ACCESS INTO AND OUT OF CHICAGO MEGABUS CLINTON STREET TERMINAL AT ALL TIMES UNLESS COORDINATED PER MEGABUS TERMINAL COORDINATION SPECIAL PROVISION. COORDINATION WITH MEGABUS USA, LLC IS REQUIRED.
7. MAINTAIN DIVVY BIKE SHARE STATION AT ALL TIMES. COORDINATION WITH CITY OF CHICAGO IS REQUIRED.
8. SEE DETOUR PLAN FOR THE CANAL STREET ENTRANCE RAMP CLOSURE.

PROPOSED TEMP PAVEMENT MARKINGS

- (A) TEMP EPOXY PVT MK LINE 4 (SOLID WHITE)
- (B) TEMP EPOXY PVT MK LINE 4 (SOLID YELLOW)
- (C) TEMP EPOXY PVT MK LINE 4 (2' DASH 6' SKIP, WHITE)

* FROM PREVIOUS STAGE TO REMAIN

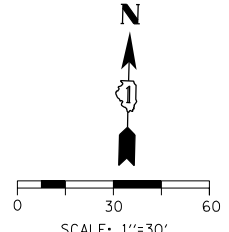

FILE PATH = P:\60288727\000_CAD\006_Roadway\Printing\60288727_2016_03-18_Final_Plot_Export\160288727-sht-Staging-LOCAL-2-02-Substage.dgn



D16078-sht-Staging-LOCAL-2-02-Substage.dgn
USER NAME = chiue
PLOT SCALE = 60.0000' / in.
PLOT DATE = 3/20/2016

DESIGNED - AFC	REVISED -
DRAWN - AFC	REVISED -
CHECKED - MSC	REVISED -
DATE - 3/18/2016	REVISED -

**STATE OF ILLINOIS
DEPARTMENT OF TRANSPORTATION**

**SUGGESTED STAGES OF CONSTRUCTION AND TRAFFIC CONTROL PLAN
LOCAL ROAD - STAGING 2A AND 2B - SUBSTAGE**

SCALE: 1" = 30' SHEET 1 OF 1 SHEETS STA. TO STA.









F.A.I. RTE.	SECTION	COUNTY	TOTAL SHEETS	SHEET NO.
90/94/290	2014-004R&B	COOK	706	110
CONTRACT NO. 60X78				
ILLINOIS FED. AID PROJECT				

EROSION CONTROL GENERAL NOTES



1. THE CONSTRUCTION LIMITS WILL BE STAKED AND APPROVED BY THE ENGINEER PRIOR TO COMMENCING CONSTRUCTION. THE CONSTRUCTION LIMITS MAY BE ADJUSTED BY THE ENGINEER TO PRESERVE TREES AND NO ADDITIONAL COMPENSATION WILL BE PAID TO THE CONTRACTOR FOR CHANGES IN CONSTRUCTION LIMITS.
2. EROSION CONTROL ITEMS ARE CONSIDERED HIGH PRIORITY ITEMS IN THIS CONTRACT. THE CONTRACTOR WILL IMPLEMENT ALL PROVISIONS OF SPECIFICATION NECESSARY TO ASSURE THAT EROSION CONTROL ITEMS ARE CONSTRUCTED AND MAINTAINED IN A TIMELY MANNER. THE CONTRACTOR SHALL INSTALL TEMPORARY EROSION CONTROL MEASURES PRIOR TO THE START OF CONSTRUCTION OPERATIONS WHICH WILL POTENTIALLY CREATE ERODIBLE CONDITIONS. PLACEMENT AND MAINTENANCE OF TEMPORARY EROSION CONTROL SYSTEMS WILL BE UTILIZED THROUGHOUT THE CONSTRUCTION LIMITS.
3. THE CONTRACTOR WILL ASSUME RESPONSIBILITY FOR MAINTENANCE OF ALL SOIL EROSION CONTROL DURING CONSTRUCTION.
4. TEMPORARY EROSION CONTROL MEASURES SHALL BE CONSTRUCTED AS SHOWN ON THE PLANS AND AS DIRECTED BY THE ENGINEER. THE WORK SHALL BE COMPLETED IN ACCORDANCE WITH SECTION 280 OF THE STANDARD SPECIFICATIONS, CONTRACT SPECIAL PROVISIONS AND THE STORM WATER POLLUTION PREVENTION PLAN (SWPPP).
5. ALL EROSION CONTROL MEASURES WILL BE MAINTAINED IN ACCORDANCE WITH THE IDOT EROSION AND SEDIMENT CONTROL FIELD GUIDE FOR CONSTRUCTION INSPECTION AND IDOTS BEST MANAGEMENT PRACTICES.
6. THE CONTRACTOR SHALL UTILIZE THE GENERAL MAINTENANCE GUIDELINES AS OUTLINED IN THE SWPPP TO ENSURE GOOD AND EFFECTIVE OPERATING CONDITION OF THE VEGETATION AND EROSION AND SEDIMENT CONTROL MEASURES.
7. A COPY OF THE APPROVED EROSION AND SEDIMENT CONTROL PLAN SHALL BE MAINTAINED ON SITE. ALL CHANGES TO THE SOIL EROSION AND SEDIMENT CONTROL PLAN SHALL BE NOTED ON THE SITE.
8. THE CONTRACTOR SHALL PERFORM ALL WORK AS DIRECTED BY THE ENGINEER AND AS SHOWN IN HIGHWAY STANDARD 280001 STRAW BALES OR SILT FENCE SHALL NOT BE ALLOWED FOR INLET FILTERS.
9. THE EROSION CONTROL MEASURES SHOWN ARE BUT A GRAPHICAL REPRESENTATION OF SUGGESTED MEASURES. DEVIATIONS FROM THIS PLAN ARE TO BE EXPECTED PENDING A JOBSITE INSPECTION BETWEEN THE CONTRACTOR AND THE DEPARTMENT.
10. THE CONTRACTOR WILL BE REQUIRED TO IMPLEMENT AND MAINTAIN SEDIMENT CONTROL MEASURES PRIOR TO STRIPPING EXISTING VEGETATION.
11. THE CONTRACTOR SHALL INSPECT ALL EROSION AND SEDIMENT CONTROL MEASURES WEEKLY AND AFTER EACH RAINFALL, 0.5 INCHES OR GREATER IN A 24 HOUR PERIOD, OR EQUIVALENT SNOWFALL. ADDITIONALLY DURING WINTER MONTHS, ALL MEASURES SHOULD BE CHECKED AFTER EACH SIGNIFICANT SNOWMELT. ANY NECESSARY REPAIRS OR CLEANUP TO MAINTAIN THE EFFECTIVENESS OF SAID MEASURES SHALL BE MADE IMMEDIATELY.
12. TEMPORARY EROSION CONTROL SEEDING SHALL BE APPROVED PER SUB-STAGE AS SOON AS ROUGH GRADING IS ACTIVE IN A SECTION. STABILIZATION OF DISTURBED AREAS MUST BE INITIATED WITHIN 1 WORKING DAY OF TEMPORARY OR PERMANENT CESSATION OF EARTH DISTURBING ACTIVITIES AND SHALL BE COMPLETED AS SOON AS POSSIBLE BUT NO LATER THAN 14 DAYS FROM THE INITIATION OF STABILIZATION OF WORK IN AN AREA.
13. MULCH, METHOD 2 AND SURFACE ROUGHENING SHALL BE USED FOR TEMPORARY STABILIZATION DURING WINTER IN ADDITION TO TEMPORARY EROSION CONTROL SEEDING WHEN GRADING WILL OCCUR WHILE THE GROUND IS SNOW COVERED WHEN TEMPORARY SEED WILL NOT GERMINATE AND PROVIDE EROSION CONTROL PROTECTION UNTIL THE FOLLOWING SPRING. SURFACE ROUGHENING WILL NOT BE PAID FOR SEPARATELY BUT SHALL BE INCLUDED IN THE COST OF MULCH, METHOD 2.
14. ANY AREA WHERE THERE IS NO PROPOSED GRADING THE EXISTING GROUND COVER SHALL REMAIN.
15. TEMPORARY STOCKPILE LOCATIONS SHALL BE APPROVED BY THE ENGINEER AND WILL REQUIRE SILT FENCE AND TEMPORARY SEEDING.

16. THE CONTRACTOR SHALL INSTALL AND MAINTAIN INLET FILTERS AT ALL EXISTING INLETS ADJACENT TO THE EDGE OF PAVEMENT PRIOR TO THE START OF PRE-STAGE WORK. THE INLET FILTERS SHALL BE MAINTAINED AT EACH SUBSEQUENT STAGE UNTIL NO LONGER REQUIRED OR AS DIRECTED BY THE ENGINEER. THE INSTALLATION, MAINTENANCE AND ROUTINE CLEANING OF INLET FILTERS ARE INCLUDED IN THE COST OF INLET FILTERS.
17. THE CONTRACTOR SHALL IMMEDIATELY INSTALL AND MAINTAIN INLET FILTERS AT ALL NEW OPEN LID INLETS AND DRAINAGE STRUCTURES. THE INLET FILTERS SHALL BE MAINTAINED AT EACH SUBSEQUENT STAGE UNTIL COMPLETION OF STAGING OR UNTIL NO LONGER REQUIRED. THE INSTALLATION, MAINTENANCE AND ROUTINE CLEANING OF INLET FILTERS ARE INCLUDED IN THE COST OF INLET FILTERS.
18. DURING CONSTRUCTION OPERATIONS, WHEN ANY LOOSE MATERIAL IS DEPOSITED IN THE FLOW LINE OF DITCHES, GUTTERS OR DRAINAGE STRUCTURES SO THAT THE NATURAL FLOW OF WATER IS OBSTRUCTED, THE MATERIAL SHALL BE REMOVED AT THE CLOSE OF EACH WORKING DAY.
19. AT THE CONCLUSION OF CONSTRUCTION OPERATIONS, ALL DRAINAGE STRUCTURES SHALL BE FREE FROM DIRT AND DEBRIS. THIS WORK WILL NOT BE PAID FOR SEPARATELY BUT SHALL BE INCLUDED IN THE COST INLET FILTERS.
20. THE CONTRACTOR SHOULD PROVIDE TO THE RESIDENT ENGINEER A PLAN TO ENSURE THAT A STABILIZED FLOW LINE WILL BE PROVIDED DURING STORM SEWER CONSTRUCTION. THE USE OF A STABILIZED FLOW LINE BETWEEN INSTALLED STORM SEWER AND OPEN DISTURBANCE WILL REDUCE THE POTENTIAL FOR THE OFFSITE DISCHARGE OF SEDIMENT-BEARING WATERS, ESPECIALLY WHEN RAIN IS FORECASTED, SO THAT FLOW WILL NOT ERODE. LACK OF APPROVED PLAN OR FAILURE TO COMPLY WILL RESULT IN AN ESC DEFICIENCY DEDUCTION.
21. LOCATIONS OF THE STABILIZED CONSTRUCTION ENTRANCE/EXITS SHALL BE DETERMINED BY THE CONTRACTOR AND APPROVED BY THE ENGINEER. THE INSTALLATION OF THE CONSTRUCTION ENTRANCE/EXITS SHALL BE IN ACCORDANCE WITH THE ILLINOIS URBAN MANUAL OR AS DIRECTED BY THE ENGINEER.
22. TEMPORARY OR PERMANENT STABILIZATION SHALL BE INSTALLED ON ALL AREAS DISTURBED DURING EACH STAGE OF CONSTRUCTION PRIOR TO SWITCHING TRAFFIC TO BEGIN THE SUBSEQUENT STAGE. ALSO, ALL EROSION CONTROL MEASURES PLACED DURING CONSTRUCTION SHALL REMAIN IN PLACE AND BE MAINTAINED UNTIL COMPLETION OF THE FINAL STAGE OF CONSTRUCTION OR WHEN NO LONGER REQUIRED.
23. FOR PERMANENT EROSION CONTROL, THE CONTRACTOR SHALL PLACE TOPSOIL SO THAT IT HAS A BOND WITH THE EXISTING SURFACE TO WHICH IT IS APPLIED, IT SHALL BE DISKED OR RAKED OR OTHERWISE BROKEN UP IF NECESSARY TO PROVIDE SUCH BOND. EXISTING DRAINAGE PATTERNS SHALL BE MAINTAINED AND EXISTING STRUCTURE RIMS SHALL NOT BE COVERED. EXISTING VEGETATION SHALL NOT BE COVERED. BONDING TOPSOIL IS INCLUDED IN THE COST OF THE TOPSOIL FURNISH AND PLACE, 4" AND NO ADDITIONAL COMPENSATION WILL BE ALLOWED.
24. UNDER NO CIRCUMSTANCES SHALL THE CONTRACTOR PROLONG FINAL GRADING AND SHAPING SO THAT THE ENTIRE PROJECT CAN BE PERMANENTLY SEED AT ONE TIME.
25. THE CONTRACTOR SHALL COORDINATE OVERLAPPING WORK AREAS, SEQUENCING OF CONSTRUCTION, AND THE PLACEMENT AND MAINTENANCE OF EROSION CONTROL MEASURES WITH ADJACENT CONTRACT(S) AND AT THE DIRECTION OF THE ENGINEER.

TEMPORARY EROSION CONTROL LEGEND

-  INLET FILTER
-  INLET FILTER (TO REMAIN FROM PREVIOUS STAGE)
-  PERIMETER EROSION BARRIER
-  MULCH, METHOD 2
-  TEMPORARY EROSION CONTROL SEEDING OR SURFACE ROUGHENING (SEE NOTE 13)
-  PROTECTION OF EXISTING TREES (PAID FOR AS TEMPORARY FENCE, TREE TRUNK PROTECTION AND TREE PRUNING)
-  STONE RIPRAP, CLASS A1 FILTER FABRIC
-  WORK ZONE
-  PROPOSED PAVEMENT CONSTRUCTED IN PREVIOUS STAGE

PERMANENT EROSION CONTROL LEGEND

-  EROSION CONTROL BLANKET SEEDING, CLASS 2A
-  NITROGEN FERTILIZER NUTRIENT POTASSIUM FERTILIZER NUTRIENT TOPSOIL FURNISH AND PLACE, 4"
-  STONE RIPRAP, CLASS A4 FILTER FABRIC

FILE PATH = P:\60288727\000_CAD\006_Roadway\Printing\60288727\2016-03-18_Final_Plot_Erosion-Notes.dgn



016078-sht-Eros-Notes.dgn
 USER NAME = chiuo
 PLOT SCALE = 100.0000' / in.
 PLOT DATE = 3/20/2016

DESIGNED - AFC
 DRAWN - AFC
 CHECKED - DBM
 DATE - 3/18/2016

REVISED -
 REVISED -
 REVISED -
 REVISED -

STATE OF ILLINOIS
 DEPARTMENT OF TRANSPORTATION

EROSION CONTROL GENERAL NOTES

SCALE: NTS SHEET 1 OF 1 SHEETS STA. TO STA.

F.A.I. RTE.	SECTION	COUNTY	TOTAL SHEETS	SHEET NO.
90/94/290	2014-004R&B	COOK	706	111
CONTRACT NO. 60X78			ILLINOIS FED. AID PROJECT	

TEMPORARY EROSION CONTROL SCHEDULE

STAGES	TEMPORARY FENCE	TREE TRUNK PROTECTION	TREE PRUNING (1 TO 10 INCH DIAMETER)	SUPPLEMENTAL WATERING	NITROGEN FERTILIZER NUTRIENT	POTASSIUM FERTILIZER NUTRIENT	MULCH, METHOD 2	TEMPORARY EROSION CONTROL SEEDING	PERIMETER EROSION BARRIER	INLET FILTERS	STONE RIPRAP, CLASS A1	FILTER FABRIC	DUST CONTROL WATERING
	FOOT	EACH	EACH	UNIT	POUND	POUND	ACRE	POUND	FOOT	EACH	SQ YD	SQ YD	UNIT
STAGE 1	-	-	-	-	-	-	0.37	732	878	47	71	71	3.5
STAGE 2A	-	-	-	-	-	-	0.42	460	1144	38	-	-	4.1
STAGE 2B	120	4	4	0.1	2	2	0.67	1611	1645	-	-	-	6.5
TOTAL	120	4	4	0.1	2	2	1.46	2803	3667	85	71	71	14.1
ROUNDED TOTAL	120	4	4	0.1	2	2	1.50	2803	3667	85	71	71	14.1

PERMANENT EROSION CONTROL SCHEDULE

	TOPSOIL FURNISH AND PLACE, 4"	SEEDING, CLASS 2A	NITROGEN FERTILIZER NUTRIENT	POTASSIUM FERTILIZER NUTRIENT	EROSION CONTROL BLANKET	STONE RIPRAP, CLASS A4	FILTER FABRIC
	SQ YD	ACRE	POUND	POUND	SQ YD	SQ YD	SQ YD
PERMANENT CONDITION	7010	1.45	130	130	7010	205	205
ROUNDED TOTAL	7010	1.50	130	130	7010	205	205

INLET FILTERS SCHEDULE (STAGE 1)

LOCATION		ALIGNMENT	AMOUNT (EACH)
STATION	OFFSET		
5217+77	30.4' LT	P-CON-WB	1
5217+72	30.6' LT	P-CON-WB	1
5217+56	35.2' LT	P-CON-WB	1
5217+45	29.2' LT	P-CON-WB	1
5217+37	51.3' LT	P-CON-WB	1
5217+26	60.7' LT	P-CON-WB	1
5216+67	30.9' LT	P-CON-WB	1
5216+31	82.1' LT	P-CON-WB	1
5215+76	68.5' LT	P-CON-WB	1
5215+73	25.5' LT	P-CON-WB	1
5215+35	29.4' LT	P-CON-WB	1
5214+49	38.7' LT	P-CON-WB	1
5212+74	17.4' LT	P-CON-WB	1
5211+92	114.3' LT	P-CON-WB	1
5210+71	62.8' RT	P-CON-WB	1
5210+40	110.8' LT	P-CON-WB	1
5209+80	24.2' LT	P-CON-WB	1
5209+76	25.1' LT	P-CON-WB	1
5209+51	25.1' LT	P-CON-WB	1
5209+36	25.1' LT	P-CON-WB	1
5208+30	30.8' LT	P-CON-WB	1
5208+30	51.6' LT	P-CON-WB	1
5208+03	110.6' LT	P-CON-WB	1
5207+81	58.1' RT	P-CON-WB	1
5207+39	25.1' LT	P-CON-WB	1
5207+31	25.1' LT	P-CON-WB	1
5207+25	24.9' LT	P-CON-WB	1
5206+76	25.1' LT	P-CON-WB	1
5206+70	25.1' LT	P-CON-WB	1
5206+63	25.1' LT	P-CON-WB	1
5206+59	24.3' LT	P-CON-WB	1
5206+00	25.1' LT	P-CON-WB	1
5205+84	25.1' LT	P-CON-WB	1
5205+79	24.1' LT	P-CON-WB	1
5205+12	24.9' LT	P-CON-WB	1
5205+05	24.9' LT	P-CON-WB	1
5205+00	23.8' LT	P-CON-WB	1
5205+04	58.3' RT	P-CON-WB	1
5205+02	115.73' LT	P-CON-WB	1
5204+24	24.0' LT	P-CON-WB	1
5204+18	23.9' LT	P-CON-WB	1
5204+11	22.6' LT	P-CON-WB	1
5204+05	59.0' RT	P-CON-WB	1
5204+00	111.8' LT	P-CON-WB	1
5203+25	21.5' LT	P-CON-WB	1
5202+31	20.7' LT	P-CON-WB	1
5201+18	20.4' LT	P-CON-WB	1
TOTAL			47

INLET FILTERS SCHEDULE (STAGE 2A)

LOCATION		ALIGNMENT	AMOUNT (EACH)
STATION	OFFSET		
15+36	27.4' LT	E-KDR-SB	1
15+23	21.2' LT	E-KDR-SB	1
15+07	39.0' RT	E-KDR-SB	1
15+05	46.4' RT	E-KDR-SB	1
14+92	41.2' RT	E-KDR-NB	1
5215+86	26.5' RT	P-CON-WB	1
5214+82	20.0' RT	P-CON-WB	1
5214+57	20.3' RT	P-CON-WB	1
5214+57	29.1' RT	P-CON-WB	1
5214+58	35.1' RT	P-CON-WB	1
5214+09	20.9' RT	P-CON-WB	1
5214+04	20.9' RT	P-CON-WB	1
5213+02	20.0' RT	P-CON-WB	1
5212+92	30.4' RT	P-CON-WB	1
5212+87	124.9' RT	P-CON-WB	1
5212+10	30.2' RT	P-CON-WB	1
5210+46	55.3' RT	P-CON-WB	1
5209+77	53.6' RT	P-CON-WB	1
5207+26	51.8' RT	P-CON-WB	1
5206+58	52.0' RT	P-CON-WB	1
5206+57	52.7' RT	P-CON-WB	1
5205+84	52.7' RT	P-CON-WB	1
5205+78	51.9' RT	P-CON-WB	1
5205+05	52.9' RT	P-CON-WB	1
5205+01	52.2' RT	P-CON-WB	1
5204+25	53.8' RT	P-CON-WB	1
5204+18	53.9' RT	P-CON-WB	1
5204+12	50.9' RT	P-CON-WB	1
5203+28	54.9' RT	P-CON-WB	1
5203+26	51.8' RT	P-CON-WB	1
5203+26	29.0' RT	P-CON-WB	1
5202+60	85.8' RT	P-CON-WB	1
5202+55	55.7' RT	P-CON-WB	1
5202+40	52.6' RT	P-CON-WB	1
5202+34	29.9' RT	P-CON-WB	1
5201+77	53.4' RT	P-CON-WB	1
3502+89	12.1' RT	P-CAN-TIL	1
3502+88	12.5' LT	P-CAN-TIL	1
TOTAL			38

INLET FILTERS SCHEDULE (STAGE 2B)

LOCATION		ALIGNMENT	AMOUNT (EACH)
STATION	OFFSET		
TOTAL			0

FILE PATH = P:\60288727\000_CAD\006_Roadway\Printing\60288727\015-03-18_F.mpl_Plot_ErosionControlSchedule.dgn



D160X78-sht-Eros-Schedule.dgn	DESIGNED - AFC	REVISED -
USER NAME = chiuw	DRAWN - AFC	REVISED -
PLOT SCALE = 100.0000' / in.	CHECKED - DBM	REVISED -
PLOT DATE = 3/20/2016	DATE - 3/18/2016	REVISED -

**STATE OF ILLINOIS
DEPARTMENT OF TRANSPORTATION**

EROSION CONTROL SCHEDULE
SCALE: NTS SHEET 1 OF 1 SHEETS STA. TO STA.

F.A.I. RTE.	SECTION	COUNTY	TOTAL SHEETS	SHEET NO.
90/94/290	2014-004R&B	COOK	706	112
CONTRACT NO. 60X78				
ILLINOIS FED. AID PROJECT				

EROSION CONTROL LAYOUT INFORMATION

POINT	STATION	OFFSET	LT/RT	BASELINE
1	5218+52	32.6'	LT	PR WB CONGRESS PKWY
2	5218+49	74.8'	LT	PR WB CONGRESS PKWY
3	14+08	111.8'	LT	EX SB I-90/94
4	13+93	90.5'	LT	EX SB I-90/94
5	13+95	24.7'	LT	EX SB I-90/94
6	14+56	25.0'	LT	EX SB I-90/94
7	14+47	27.2'	RT	EX SB I-90/94
8	13+90	27.2'	RT	EX SB I-90/94
9	13+94	33.8'	LT	EX NB I-90/94
10	14+47	33.7'	LT	EX NB I-90/94
11	13+87	27.9'	RT	EX NB I-90/94
12	14+31	28.0'	RT	EX NB I-90/94

POINT	STATION	OFFSET	LT/RT	BASELINE
17	14+00	24.8'	LT	EX SB I-90/94
18	14+20	24.9'	LT	EX SB I-90/94
19	14+20	26.3'	LT	EX SB I-90/94
20	15+27	26.6'	LT	EX SB I-90/94
21	15+27	25.2'	LT	EX SB I-90/94
22	15+45	25.2'	LT	EX SB I-90/94
23	15+45	28.0'	LT	EX SB I-90/94
24	15+27	30.6'	LT	EX SB I-90/94
25	14+48	30.0'	LT	EX SB I-90/94
26	14+36	34.2'	LT	EX SB I-90/94
27	14+00	27.6'	LT	EX SB I-90/94

POINT LOCATION

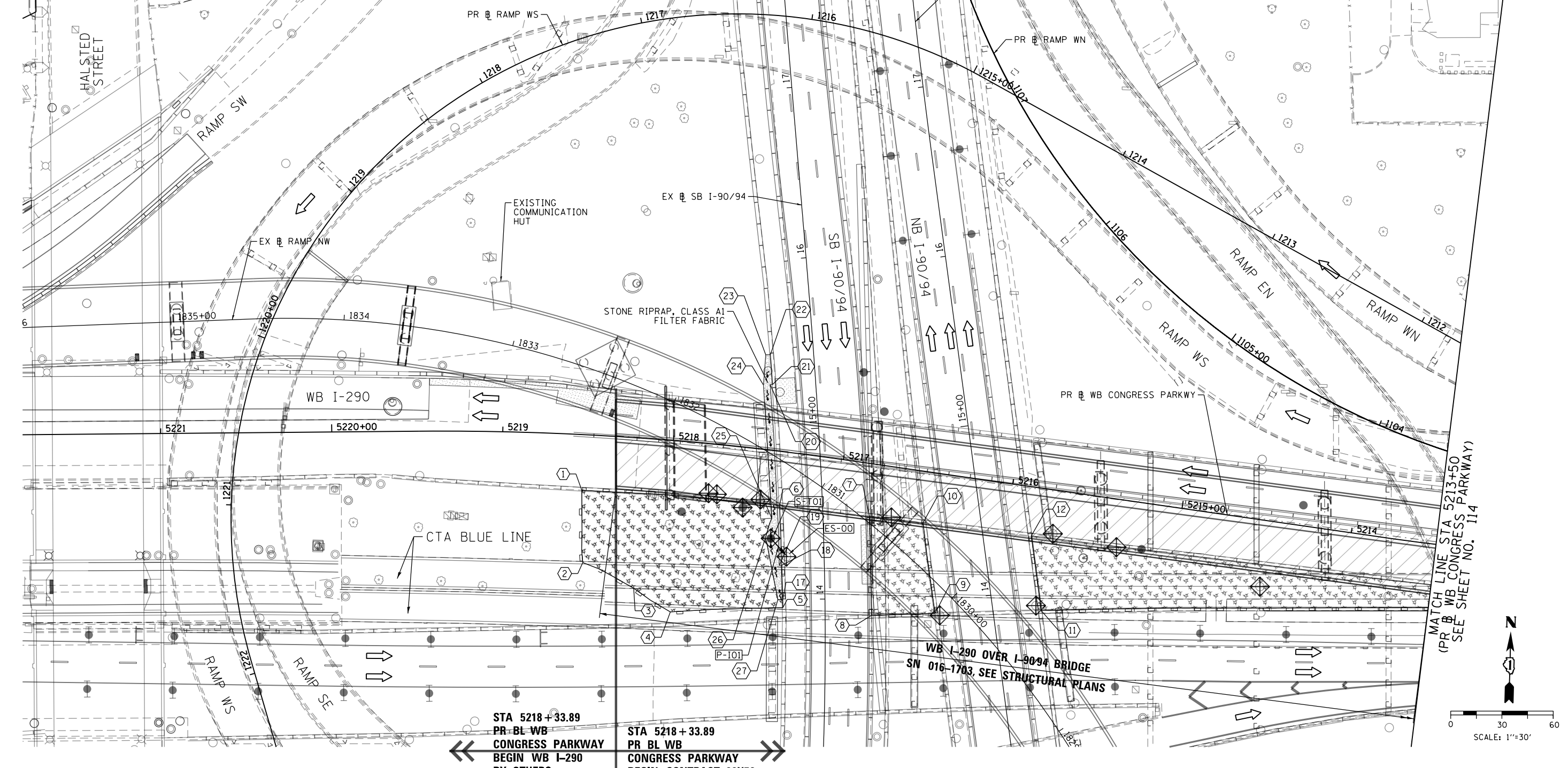

STA 5218 + 33.89
 PR BL WB CONGRESS PARKWAY
 BEGIN WB I-290 BY OTHERS

STA 5218 + 33.89
 PR BL WB CONGRESS PARKWAY
 BEGIN CONTRACT 60X78

MATCH LINE STA 5213+50
 (PR WB CONGRESS PARKWAY)
 SEE SHEET NO. 114

FILE PATH = p:\61779-PMINT\pccom\line\local\AECOM_D592_NA\Documents\01_Americas\T_energ\station\60269438_Circle\Phase_11\000_CAD\006_Roadway\Sheets\60X78_Contract\016078-sht-Eros-Staging-1-01



D160X78-sht-Eros-Staging-1-01
 USER NAME = chiue
 PLOT SCALE = 60.0000' / in.
 PLOT DATE = 3/21/2016

DESIGNED - AFC	REVISED -
DRAWN - ZND	REVISED -
CHECKED - DBM	REVISED -
DATE - 3/18/2016	REVISED -

STATE OF ILLINOIS
 DEPARTMENT OF TRANSPORTATION

EROSION AND SEDIMENTATION CONTROL PLAN
 WB I-290 OVER I-9094 AND WB CONGRESS PARKWAY - STAGE 1
 SCALE: 1" = 30' SHEET 1 OF 2 SHEETS STA. TO STA.

F.A.I. RTE. 90/94/290	SECTION 2014-004R&B	COUNTY COOK	TOTAL SHEETS 706	SHEET NO. 113
CONTRACT NO. 60X78				
ILLINOIS FED. AID PROJECT				

EROSION CONTROL LAYOUT INFORMATION

POINT	STATION	OFFSET	LT/RT	BASELINE
13	5213+24	2.7'	LT	PR WB CONGRESS PKWY
14	5213+10	34.3'	LT	PR WB CONGRESS PKWY
15	5212+98	75.0'	LT	PR WB CONGRESS PKWY
16	5212+88	74.0'	LT	PR WB CONGRESS PKWY

POINT LOCATION EX ROW

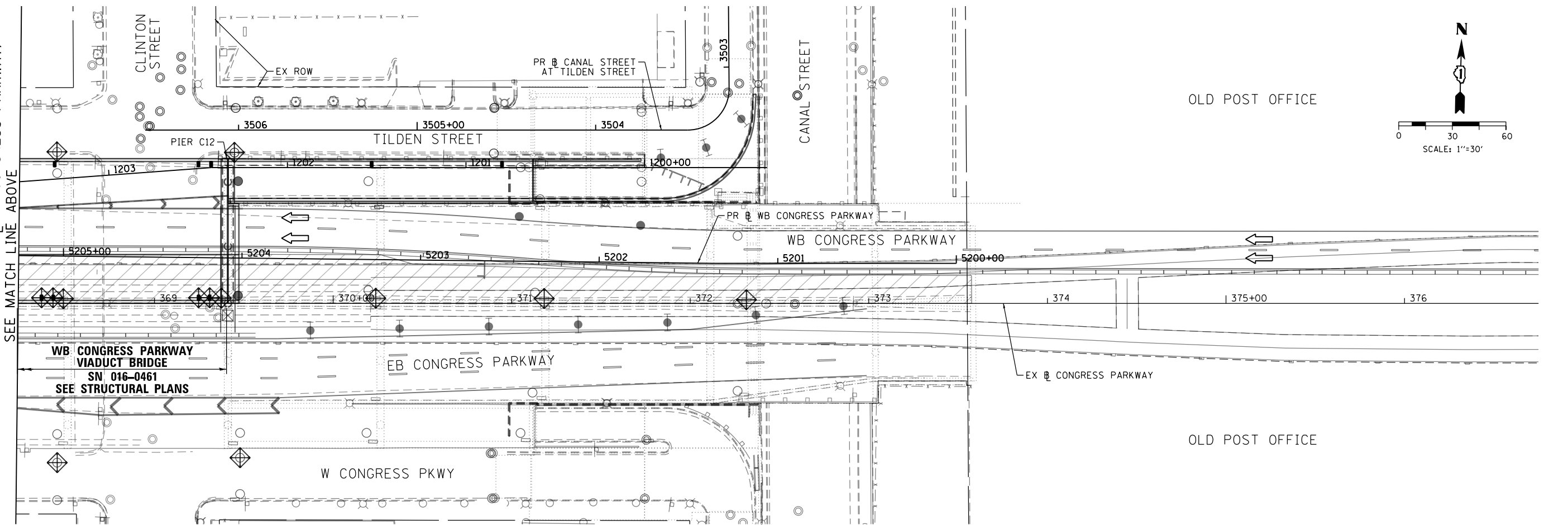
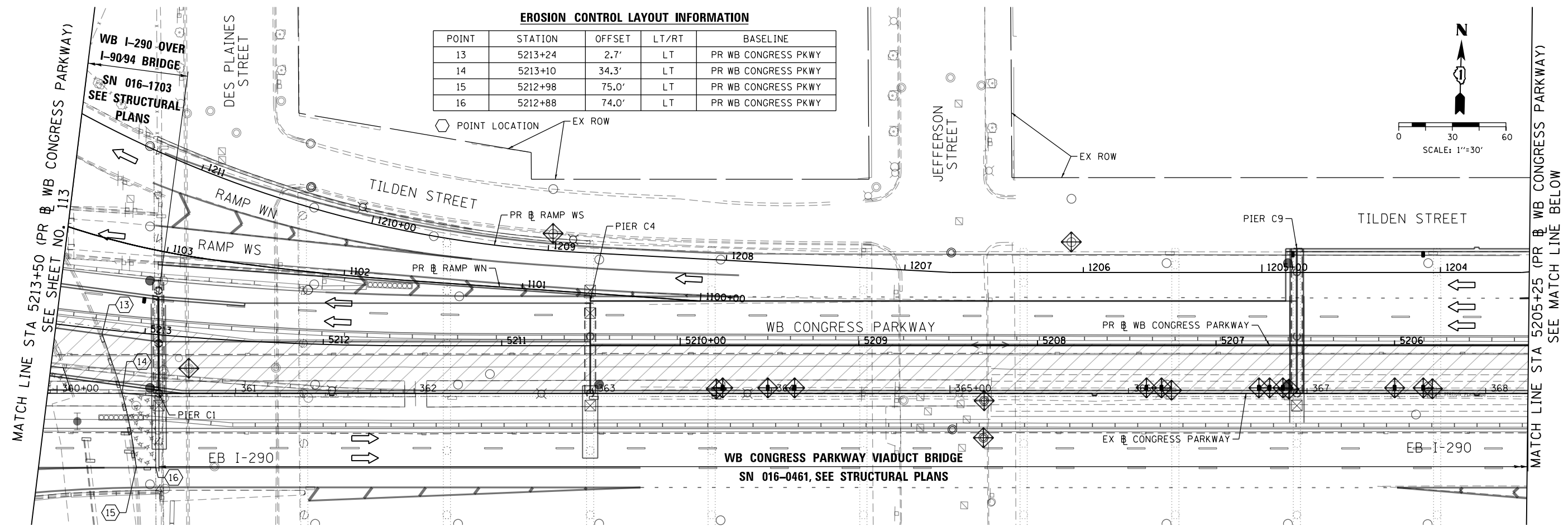
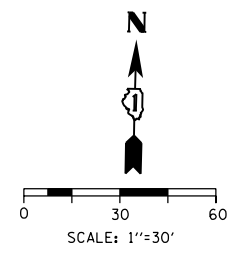

FILE PATH = p:\617479-PMINT\pccommon\line\local\AECOM_D592_MIA\Documents\01_Americas\Tr_eng\pccommon\60269938_Circle\Phase_11\000_CAD\006_Roadway\Sheets\60X78_Contract\0160X78-sht-Eros-Staging-1-02



D160X78-sht-Eros-Staging-1-02
 USER NAME = chiuw
 PLOT SCALE = 60.0000' / in.
 PLOT DATE = 3/21/2016

DESIGNED - AFC	REVISED -
DRAWN - ZND	REVISED -
CHECKED - DBM	REVISED -
DATE - 3/18/2016	REVISED -

**STATE OF ILLINOIS
 DEPARTMENT OF TRANSPORTATION**

**EROSION AND SEDIMENTATION CONTROL PLAN
 WB I-290 OVER I-90/94 AND WB CONGRESS PARKWAY - STAGE 1**
 SCALE: 1" = 30' SHEET 2 OF 2 SHEETS STA. TO STA.

F.A.I. RTE.	SECTION	COUNTY	TOTAL SHEETS	SHEET NO.
90/94/290	2014-004R&B	COOK	706	114
CONTRACT NO. 60X78				
ILLINOIS FED. AID PROJECT				

EROSION CONTROL LAYOUT INFORMATION

POINT	STATION	OFFSET	LT/RT	BASELINE
1	5218+30	28.4'	RT	PR WB CONGRESS PKWY
2	5218+26	32.6'	RT	PR WB CONGRESS PKWY
3	5218+11	40.9'	RT	PR WB CONGRESS PKWY
4	5218+15	97.0'	RT	PR WB CONGRESS PKWY
5	5218+60	171.0'	RT	PR WB CONGRESS PKWY
6	5218+53	176.5'	RT	PR WB CONGRESS PKWY
7	15+48	39.4'	LT	EX SB I-90/94
8	15+47	23.6'	LT	EX SB I-90/94
9	15+14	23.6'	LT	EX SB I-90/94
10	16+05	37.1'	RT	EX SB I-90/94
11	15+03	32.2'	RT	EX SB I-90/94
12	15+05	32.7'	LT	EX NB I-90/94

POINT	STATION	OFFSET	LT/RT	BASELINE
13	16+13	29.6'	LT	EX NB I-90/94
14	14+87	35.6'	RT	EX NB I-90/94
15	15+00	37.8'	RT	EX NB I-90/94
16	16+34	36.4'	RT	EX NB I-90/94
17	5213+86	37.3'	RT	PR WB CONGRESS PKWY
18	5213+80	31.5'	RT	PR WB CONGRESS PKWY
19	16+64	48.8'	RT	EX NB I-90/94
20	17+00	51.4'	RT	EX NB I-90/94
21	17+61	55.1'	RT	EX NB I-90/94
22	16+98	61.3'	RT	EX NB I-90/94
23	16+53	58.0'	RT	EX NB I-90/94

POINT LOCATION

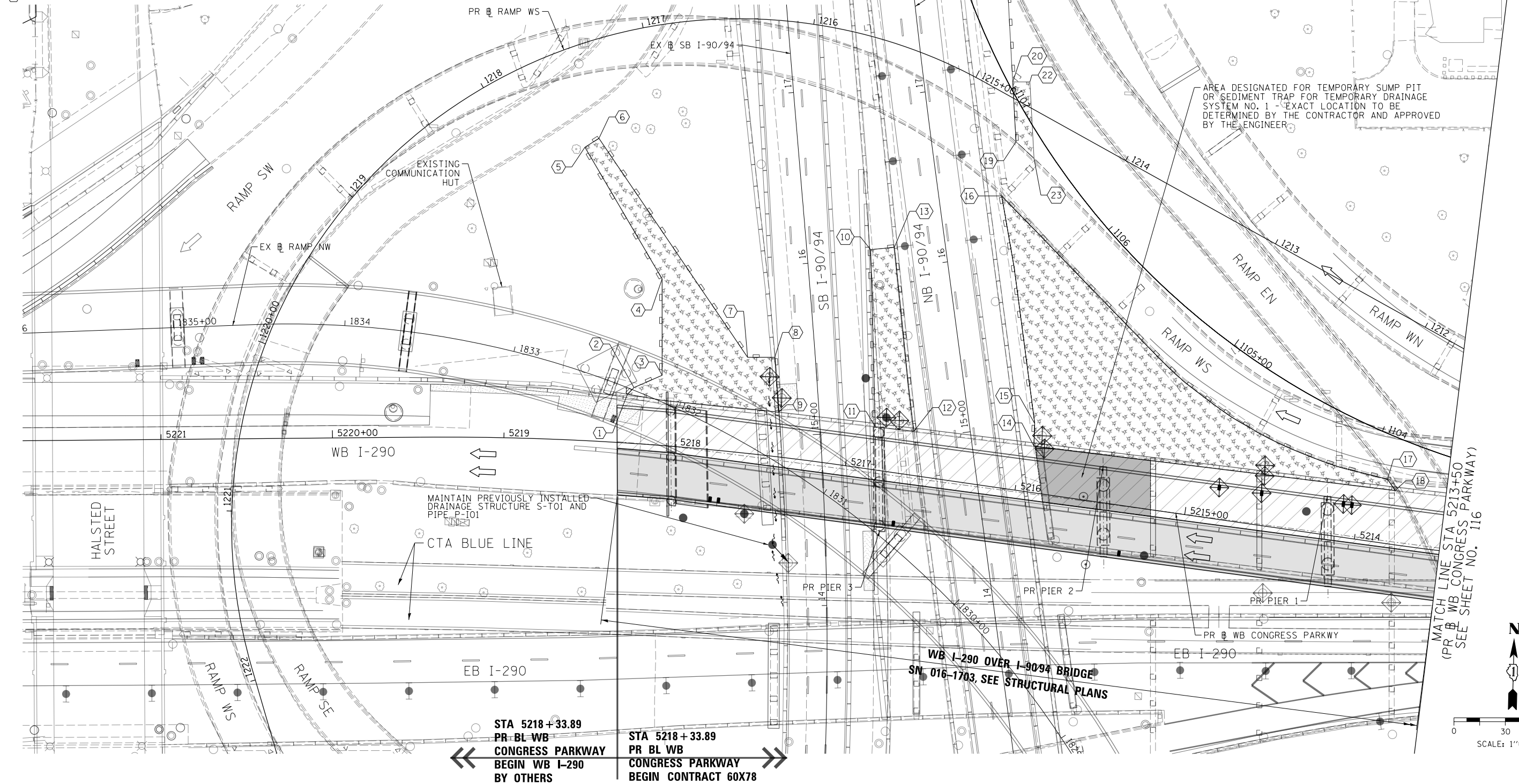

AREA DESIGNATED FOR TEMPORARY SUMP PIT OR SEDIMENT TRAP FOR TEMPORARY DRAINAGE SYSTEM NO. 1 - EXACT LOCATION TO BE DETERMINED BY THE CONTRACTOR AND APPROVED BY THE ENGINEER

MATCH LINE STA 5213+50 (PR WB CONGRESS PARKWAY) SEE SHEET NO. 116

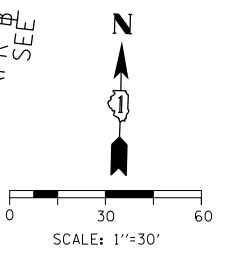

STA 5218+33.89
 PR BL WB CONGRESS PARKWAY
 BEGIN WB I-290 BY OTHERS

STA 5218+33.89
 PR BL WB CONGRESS PARKWAY
 BEGIN CONTRACT 60X78

WB I-290 OVER I-90/94 BRIDGE
 SN 016-1703. SEE STRUCTURAL PLANS

FILE PATH = P:\60288727\000_CAD\006_Roadway\Printing\60X78-2016-03-18_F.mpl_Plot_Erosion-Staging-2A-01.dgn



D160X78-sht-Eros-Staging-2A-01.dgn
 USER NAME = chiue
 PLOT SCALE = 60.0000' / in.
 PLOT DATE = 3/20/2016

DESIGNED - AFC
 DRAWN - ZND
 CHECKED - DBM
 DATE - 3/18/2016

REVISED -
 REVISED -
 REVISED -
 REVISED -

STATE OF ILLINOIS
 DEPARTMENT OF TRANSPORTATION

EROSION AND SEDIMENTATION CONTROL PLAN
 WB I-290 OVER I-90/94 AND WB CONGRESS PARKWAY - STAGE 2A
 SCALE: 1" = 30' SHEET 1 OF 2 SHEETS STA. TO STA.

F.A.I. RTE.	SECTION	COUNTY	TOTAL SHEETS	SHEET NO.
90/94/290	2014-004R&B	COOK	706	115
				CONTRACT NO. 60X78
ILLINOIS FED. AID PROJECT				

FILE PATH = p:\617479-PMINT\pccommon\line\local\AECOM\0502_MIA\Documents\01_Americas\T\engp\station\60269438_Circle\Phase_11\000_CAD\006_Roadway\Sheets\60x78_Contract\0160x78-sht-Eros-Staging-2A-02

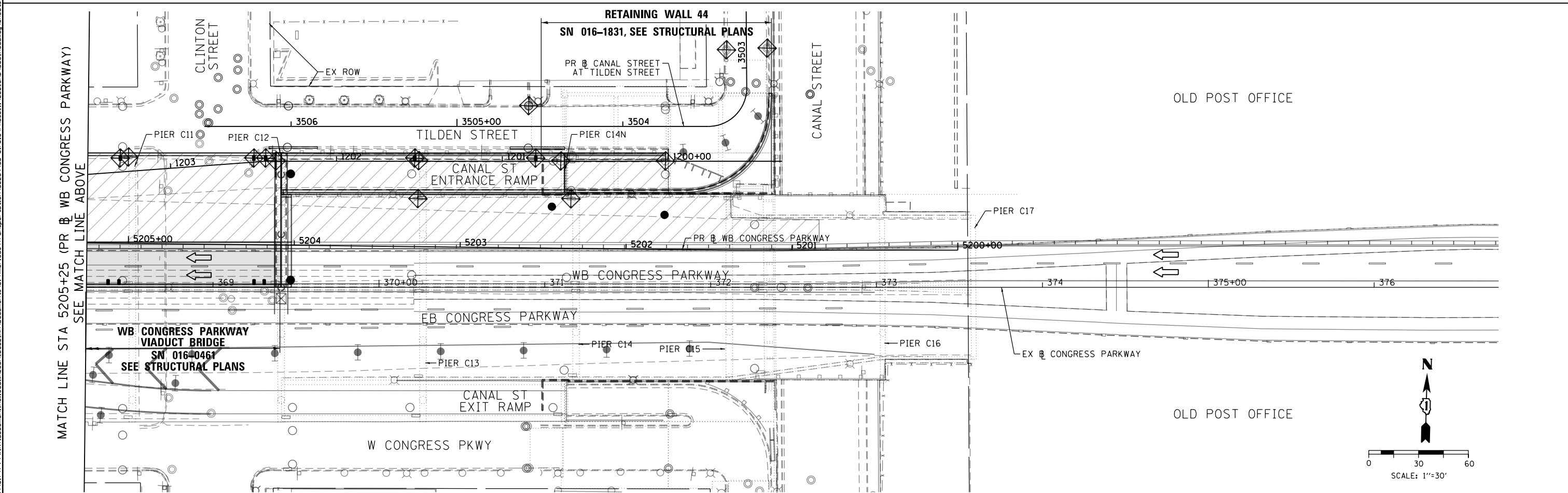
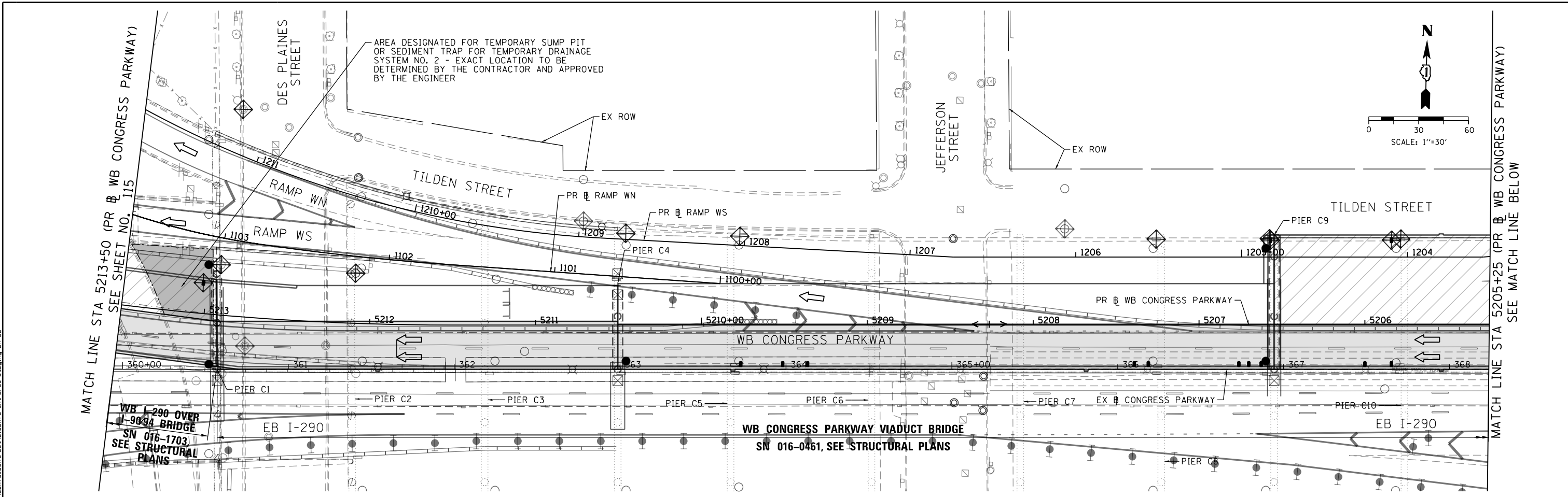

0160x78-sht-Eros-Staging-2A-02
 USER NAME = chiuw
 PLOT SCALE = 60.0000' / in.
 PLOT DATE = 3/21/2016

DESIGNED - AFC
 DRAWN - ZND
 CHECKED - DBM
 DATE - 3/18/2016

REVISED -
 REVISED -
 REVISED -
 REVISED -

STATE OF ILLINOIS
 DEPARTMENT OF TRANSPORTATION

EROSION AND SEDIMENTATION CONTROL PLAN
 WB I-290 OVER I-90/94 AND WB CONGRESS PARKWAY - STAGE 2A
 SCALE: 1" = 30' SHEET 2 OF 2 SHEETS STA. TO STA.

F.A.I. RTE.	SECTION	COUNTY	TOTAL SHEETS	SHEET NO.
90/94/290	2014-004R&B	COOK	706	116
CONTRACT NO. 60X78				
ILLINOIS FED. AID PROJECT				

EROSION CONTROL LAYOUT INFORMATION

POINT	STATION	OFFSET	LT/RT	BASELINE
1	5218+52	30.6'	LT	PR WB CONGRESS PKWY
2	5218+50	66.9'	LT	PR WB CONGRESS PKWY
3	5218+49	74.8'	LT	PR WB CONGRESS PKWY
4	5218+39	78.0'	LT	PR WB CONGRESS PKWY
5	5218+17	87.9'	LT	PR WB CONGRESS PKWY
6	5217+93	100.1'	LT	PR WB CONGRESS PKWY
7	13+95	24.7'	LT	EX SB I-90/94
8	14+54	25.0'	LT	EX SB I-90/94
9	15+14	23.6'	LT	EX SB I-90/94
10	15+47	23.6'	LT	EX SB I-90/94
11	15+48	39.4'	LT	EX SB I-90/94
12	5218+53	176.5'	RT	PR WB CONGRESS PKWY
13	5218+60	171.0'	RT	PR WB CONGRESS PKWY
14	5218+15	97.0'	RT	PR WB CONGRESS PKWY
15	5218+11	40.9'	RT	PR WB CONGRESS PKWY
16	5218+26	32.6'	RT	PR WB CONGRESS PKWY

POINT	STATION	OFFSET	LT/RT	BASELINE
17	5218+30	28.4'	RT	PR WB CONGRESS PKWY
18	16+05	37.1'	RT	EX SB I-90/94
19	15+03	32.2'	RT	EX SB I-90/94
20	15+05	32.7'	LT	EX NB I-90/94
21	16+13	29.6'	LT	EX NB I-90/94
22	14+87	35.6'	RT	EX NB I-90/94
23	15+00	37.8'	RT	EX NB I-90/94
24	16+34	36.4'	RT	EX NB I-90/94
25	5213+86	37.3'	RT	PR WB CONGRESS PKWY
26	5213+80	31.5'	RT	PR WB CONGRESS PKWY
27	5214+10	100.1'	RT	PR WB CONGRESS PKWY
28	5213+86	108.3'	RT	PR WB CONGRESS PKWY
29	5213+72	65.5'	RT	PR WB CONGRESS PKWY
30	5213+73	134.1'	RT	PR WB CONGRESS PKWY
32	5213+60	157.7'	RT	PR WB CONGRESS PKWY

○ POINT LOCATION

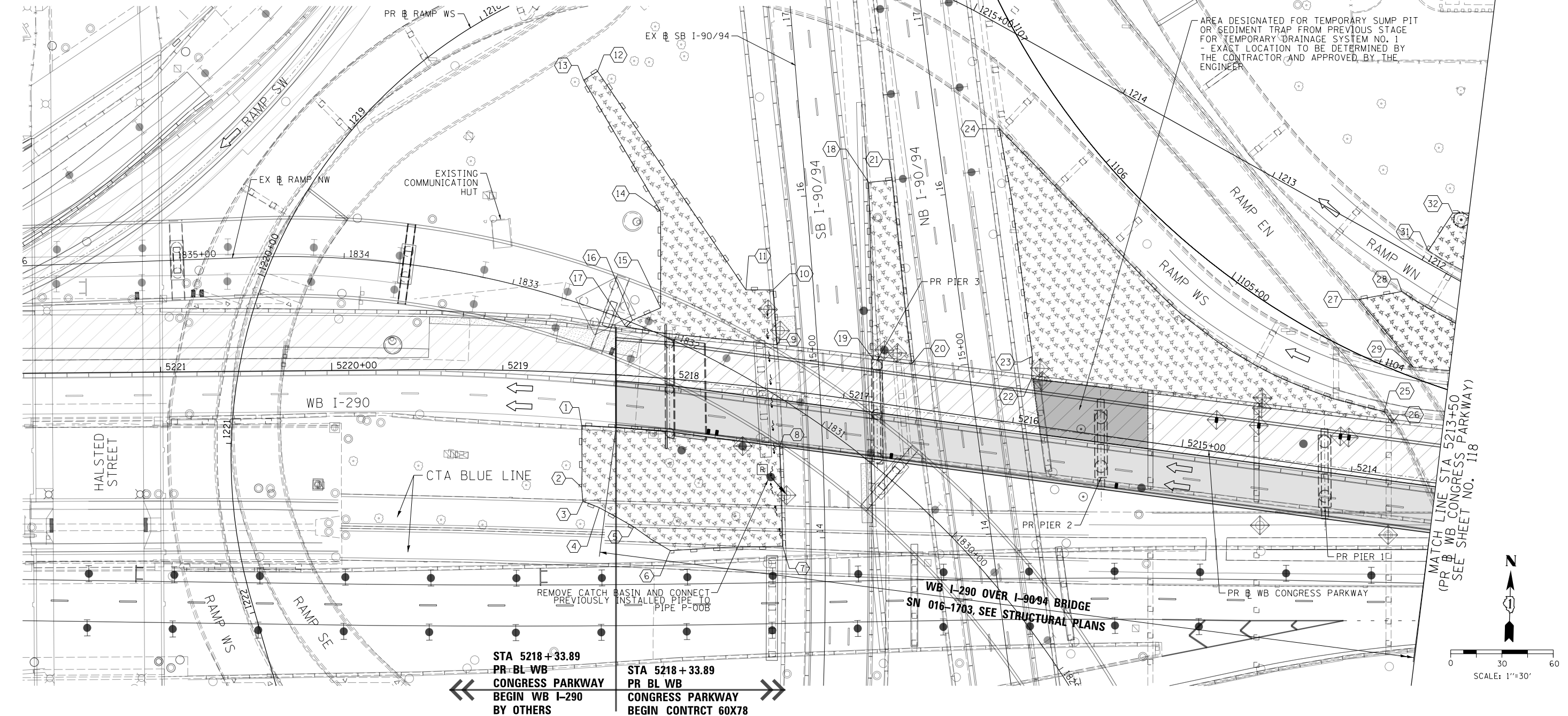

STA 5218+33.89
PR BL WB CONGRESS PARKWAY
BEGIN WB I-290 BY OTHERS

STA 5218+33.89
PR BL WB CONGRESS PARKWAY
BEGIN CONTRCT 60X78

FILE PATH = P:\60288727\000_CAD\006_Roadway\Printing\60X78-2016-03-18_F.mpl_Plot_Export\0160X78-sht-Eros-Staging-2B-01.dgn



0160X78-sht-Eros-Staging-2B-01.dgn
 USER NAME = chiuw
 PLOT SCALE = 60.0000' / in.
 PLOT DATE = 3/20/2016

DESIGNED - AFC	REVISED -
DRAWN - ZND	REVISED -
CHECKED - DBM	REVISED -
DATE - 3/18/2016	REVISED -

STATE OF ILLINOIS
DEPARTMENT OF TRANSPORTATION

EROSION AND SEDIMENTATION CONTROL PLAN
WB I-290 OVER I-90/94 AND WB CONGRESS PARKWAY - STAGE 2B
 SCALE: 1" = 30' SHEET 1 OF 2 SHEETS STA. TO STA.

F.A.I. R.E.	SECTION	COUNTY	TOTAL SHEETS	SHEET NO.
90/94/290	2014-004R&B	COOK	706	117
CONTRACT NO. 60X78			ILLINOIS FED. AID PROJECT	

FILE PATH = p:\617479-PMINT\pccom\line\local\AECOM_D592_MIA\Documents\01_Americas\T\engpccom\station\60269938_Circle\Phase_11\000_CAD\006_Roadway\Sheets\60x78_Contract\0160x78-sht-Eros-Staging-2B-02

EROSION CONTROL LAYOUT INFORMATION

POINT	STATION	OFFSET	LT/RT	BASELINE
33	1211+57	53.9'	RT	PR RAMP WS
34	1211+32	5.8'	RT	PR RAMP WS
35	1211+19	22.7'	LT	PR RAMP WS
36	1211+15	32.3'	LT	PR RAMP WS

POINT LOCATION

EX ROW

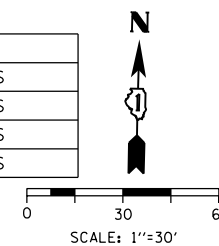

MATCH LINE STA 5205+25 (PR WB CONGRESS PARKWAY) SEE MATCH LINE BELOW

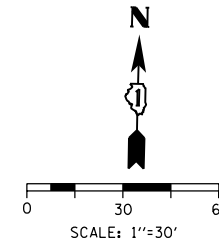
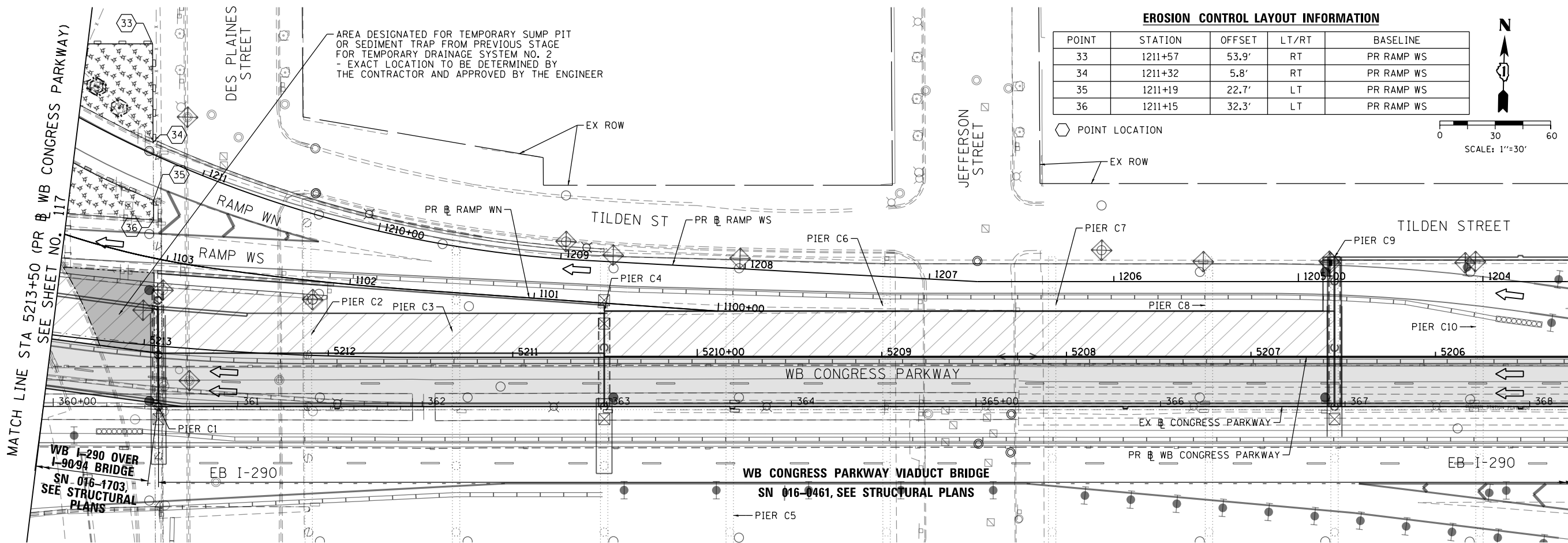

MATCH LINE STA 5205+25 (PR WB CONGRESS PARKWAY) SEE MATCH LINE ABOVE

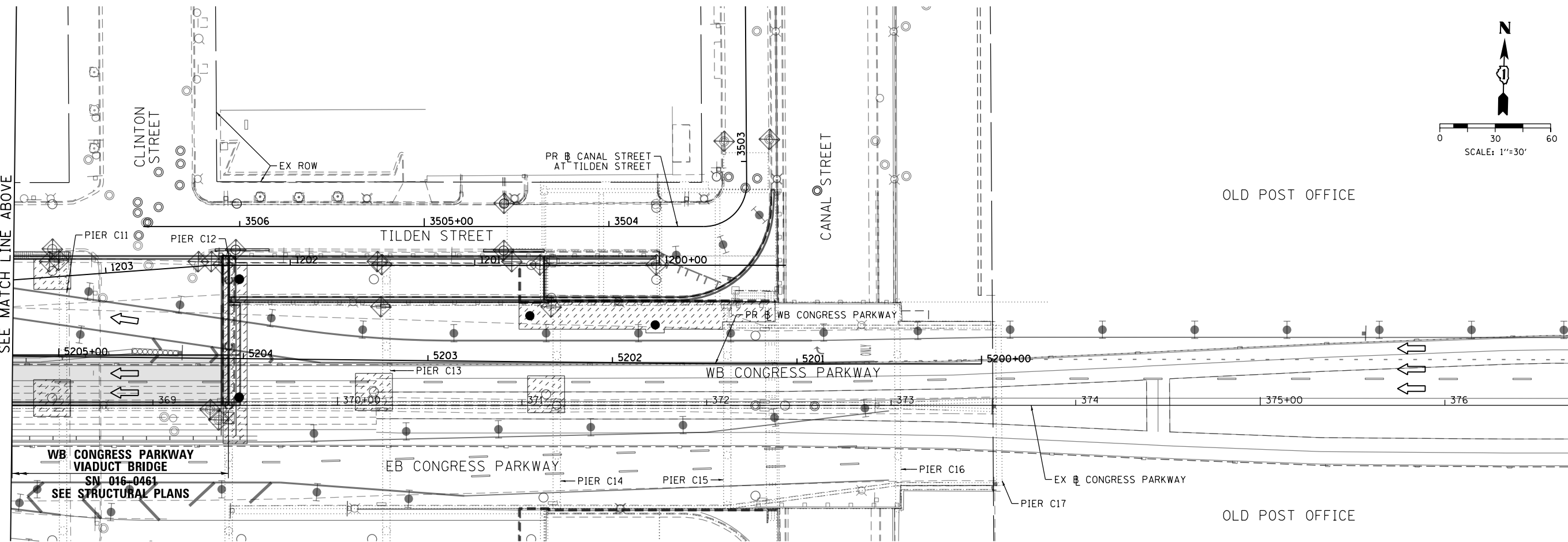

D160x78-sht-Eros-Staging-2B-02
 USER NAME = chiue
 PLOT SCALE = 60.0000' / in.
 PLOT DATE = 3/21/2016

DESIGNED - AFC
 DRAWN - ZND
 CHECKED - DBM
 DATE - 3/18/2016

REVISED -
 REVISED -
 REVISED -
 REVISED -

**STATE OF ILLINOIS
 DEPARTMENT OF TRANSPORTATION**

EROSION AND SEDIMENTATION CONTROL PLAN
WB I-290 OVER I-90/94 AND WB CONGRESS PARKWAY - STAGE 2B
 SCALE: 1" = 30' SHEET 2 OF 2 SHEETS STA. TO STA.

F.A.I. RTE.	SECTION	COUNTY	TOTAL SHEETS	SHEET NO.
90/94/290	2014-004R&B	COOK	706	118

CONTRACT NO. 60X78
 ILLINOIS FED. AID PROJECT

EROSION CONTROL LAYOUT INFORMATION

POINT	STATION	OFFSET	LT/RT	BASELINE
1	5218+35	21.8'	RT	PR WB CONGRESS PKWY
2	5218+26	32.6'	RT	PR WB CONGRESS PKWY
3	5218+11	40.9'	RT	PR WB CONGRESS PKWY
4	5218+15	97.0'	RT	PR WB CONGRESS PKWY
5	5218+60	171.0'	RT	PR WB CONGRESS PKWY
6	5218+53	176.5'	RT	PR WB CONGRESS PKWY
7	15+48	39.4'	LT	EX SB I-90/94
8	15+47	25.3'	LT	EX SB I-90/94
9	15+36	32.0'	LT	EX SB I-90/94
10	15+18	65.3'	LT	EX SB I-90/94
11	14+60	67.6'	LT	EX SB I-90/94
12	13+95	24.7'	LT	EX SB I-90/94
13	13+93	90.5'	LT	EX SB I-90/94
14	5218+17	87.9'	LT	PR WB CONGRESS PKWY
15	5218+39	78.0'	LT	PR WB CONGRESS PKWY
16	5218+49	74.8'	LT	PR WB CONGRESS PKWY
17	5218+50	66.8'	LT	PR WB CONGRESS PKWY
18	5218+52	30.6'	LT	PR WB CONGRESS PKWY
19	16+52	39.0'	RT	EX SB I-90/94
20	15+02	31.3'	RT	EX SB I-90/94

POINT	STATION	OFFSET	LT/RT	BASELINE
21	15+02	37.4'	RT	EX SB I-90/94
22	14+42	34.8'	RT	EX SB I-90/94
23	14+42	28.7'	RT	EX SB I-90/94
24	13+91	37.5'	RT	EX SB I-90/94
25	13+33	37.6'	RT	EX SB I-90/94
26	13+94	33.8'	LT	EX NB I-90/94
27	16+59	28.1'	LT	EX NB I-90/94
28	13+87	27.9'	RT	EX NB I-90/94
29	16+43	28.9'	RT	EX NB I-90/94
30	16+64	48.8'	RT	EX NB I-90/94
31	16+96	51.2'	RT	EX NB I-90/94
32	16+99	53.8'	RT	EX NB I-90/94
33	16+98	61.3'	RT	EX NB I-90/94
34	16+53	58.0'	RT	EX NB I-90/94
35	5213+86	37.4'	RT	PR WB CONGRESS PKWY
36	1212+54	26.5'	LT	PR RAMP WS
37	1212+49	15.6'	LT	PR RAMP WS
38	1212+44	12.8'	RT	PR RAMP WS
39	1212+99	6.6'	RT	PR RAMP WS
40	1211+98	32.6'	RT	PR RAMP WS

○ POINT LOCATION

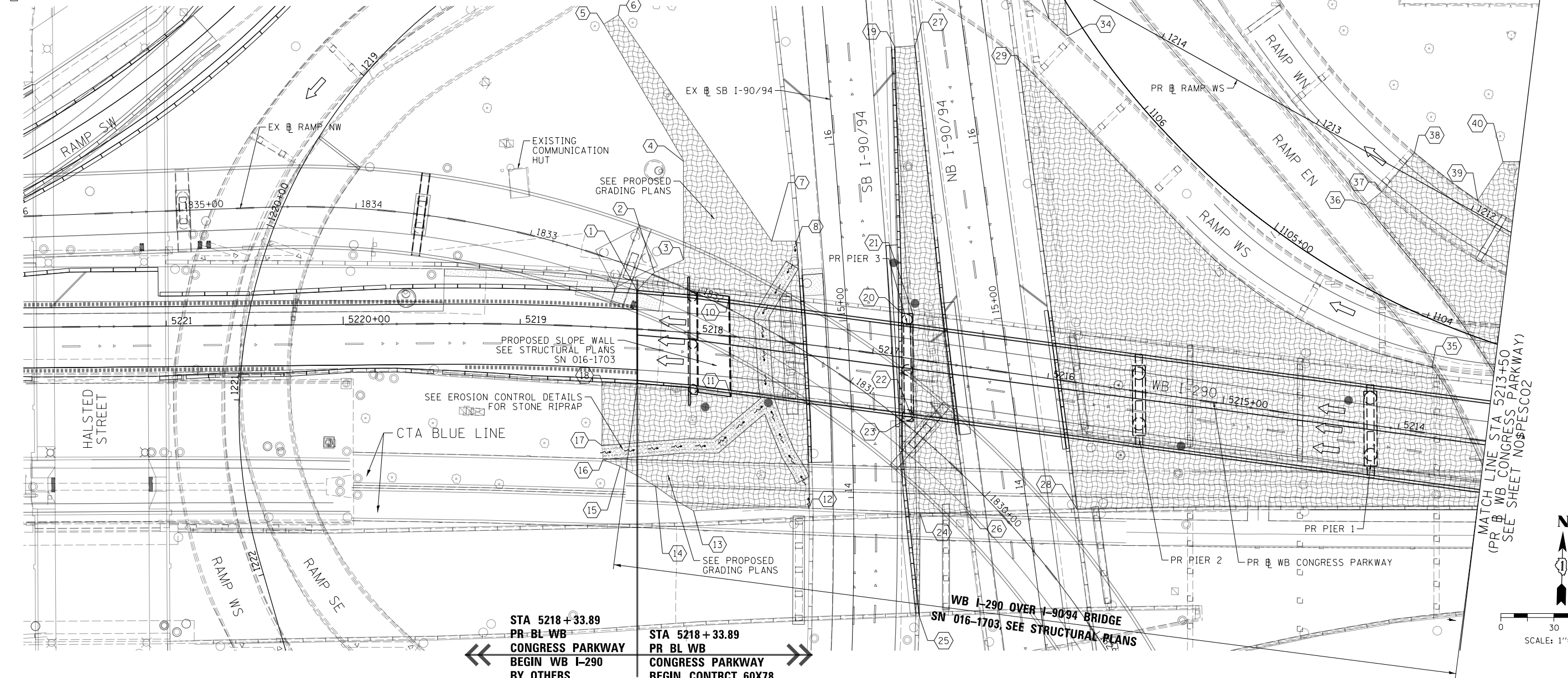

STA 5218+33.89
 PR BL WB CONGRESS PARKWAY
 BEGIN WB I-290 BY OTHERS

STA 5218+33.89
 PR BL WB CONGRESS PARKWAY
 BEGIN CONTRCT 60X78

FILE PATH = P:\60288727\000_CAD\006_Roadway\Printing\60X78_2016_03-18_F.mpl_Plot_Erosion\160X78-sht-Eros-Perm-01.dgn



0160X78-sht-Eros-Perm-01.dgn
 USER NAME = chiue
 PLOT SCALE = 60.0000' / in.
 PLOT DATE = 3/20/2016

DESIGNED - AFC	REVISED -
DRAWN - ZND	REVISED -
CHECKED - DBM	REVISED -
DATE - 3/18/2016	REVISED -

STATE OF ILLINOIS
 DEPARTMENT OF TRANSPORTATION

PERMANENT EROSION AND SEDIMENTATION CONTROL PLAN
 WB I-290 OVER I-90/94 AND WB CONGRESS PARKWAY

SCALE: 1" = 30' SHEET 1 OF 2 SHEETS STA. TO STA.

F.A.I. R.E.	SECTION	COUNTY	TOTAL SHEETS	SHEET NO.
90/94/290	2014-004R&B	COOK	706	119
CONTRACT NO. 60X78				
ILLINOIS FED. AID PROJECT				

EROSION CONTROL LAYOUT INFORMATION

POINT	STATION	OFFSET	LT/RT	BASELINE
41	1211+57	55.7'	RT	PR RAMP WS
42	5213+38	35.8'	LT	PR WB CONGRESS PKWY
43	5212+98	75.0'	LT	PR WB CONGRESS PKWY
44	5212+88	74.0'	LT	PR WB CONGRESS PKWY

POINT LOCATION EX ROW

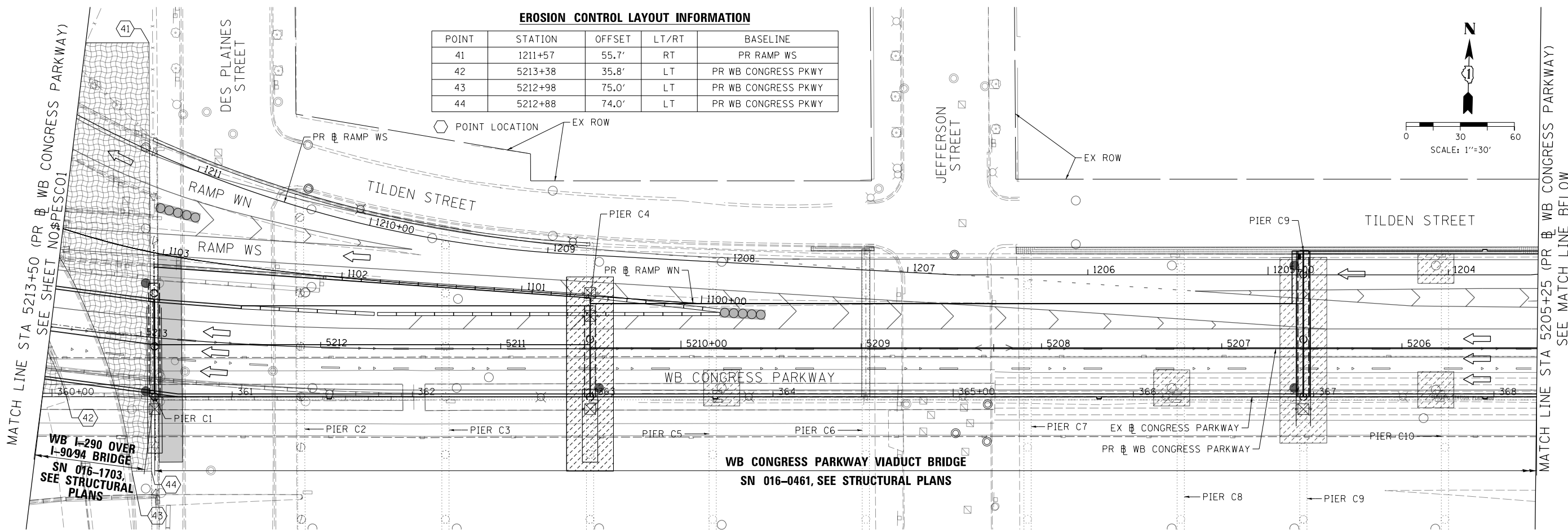
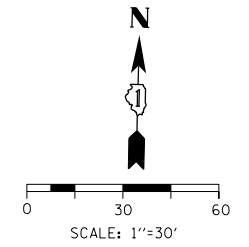

WB CONGRESS PARKWAY VIADUCT BRIDGE
SN 016-0461, SEE STRUCTURAL PLANS

RETAINING WALL 44
SN 016-1831, SEE STRUCTURAL PLANS

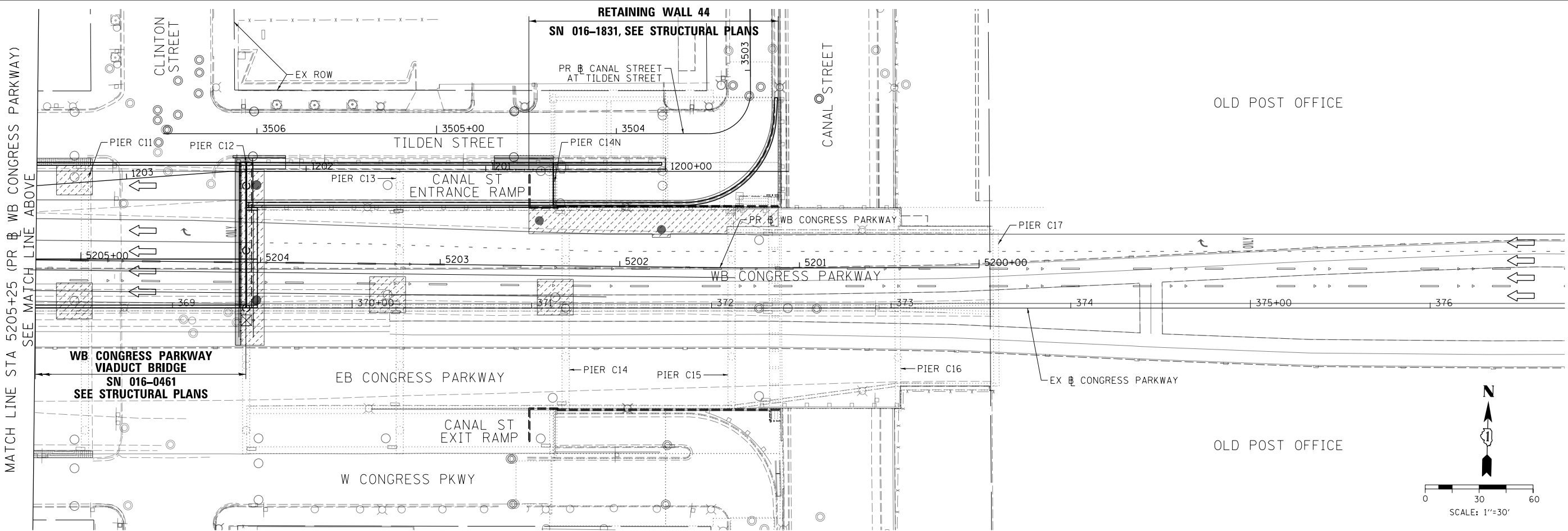

WB CONGRESS PARKWAY VIADUCT BRIDGE
SN 016-0461
SEE STRUCTURAL PLANS

STATE OF ILLINOIS
DEPARTMENT OF TRANSPORTATION

PERMANENT EROSION AND SEDIMENTATION CONTROL PLAN
WB I-290 OVER I-90/94 AND WB CONGRESS PARKWAY

F.A.I. RTE.	SECTION	COUNTY	TOTAL SHEETS	SHEET NO.
90/94/290	2014-004R&B	COOK	706	120
				CONTRACT NO. 60X78

SCALE: 1" = 30' SHEET 2 OF 2 SHEETS STA. TO STA.



D160X78-sht-Eros-Perm-02.dgn
USER NAME = chiuw
PLOT SCALE = 60.0000' / in.
PLOT DATE = 3/20/2016

DESIGNED - AFC
DRAWN - ZND
CHECKED - DBM
DATE - 3/18/2016

REVISED -
REVISED -
REVISED -
REVISED -

FILE PATH = P:\60288727\000_CAD\006_Roadway\Printing\60X78\2015-03-18_F.mpl_Plot_Eros\160X78-sht-Eros-Perm-02.dgn

FILE PATH = P:\60288727\000_CAD\006_Roadway\Printing\60288727\2015-03-18_Final_Plot_Erosion-Detail-01.dgn

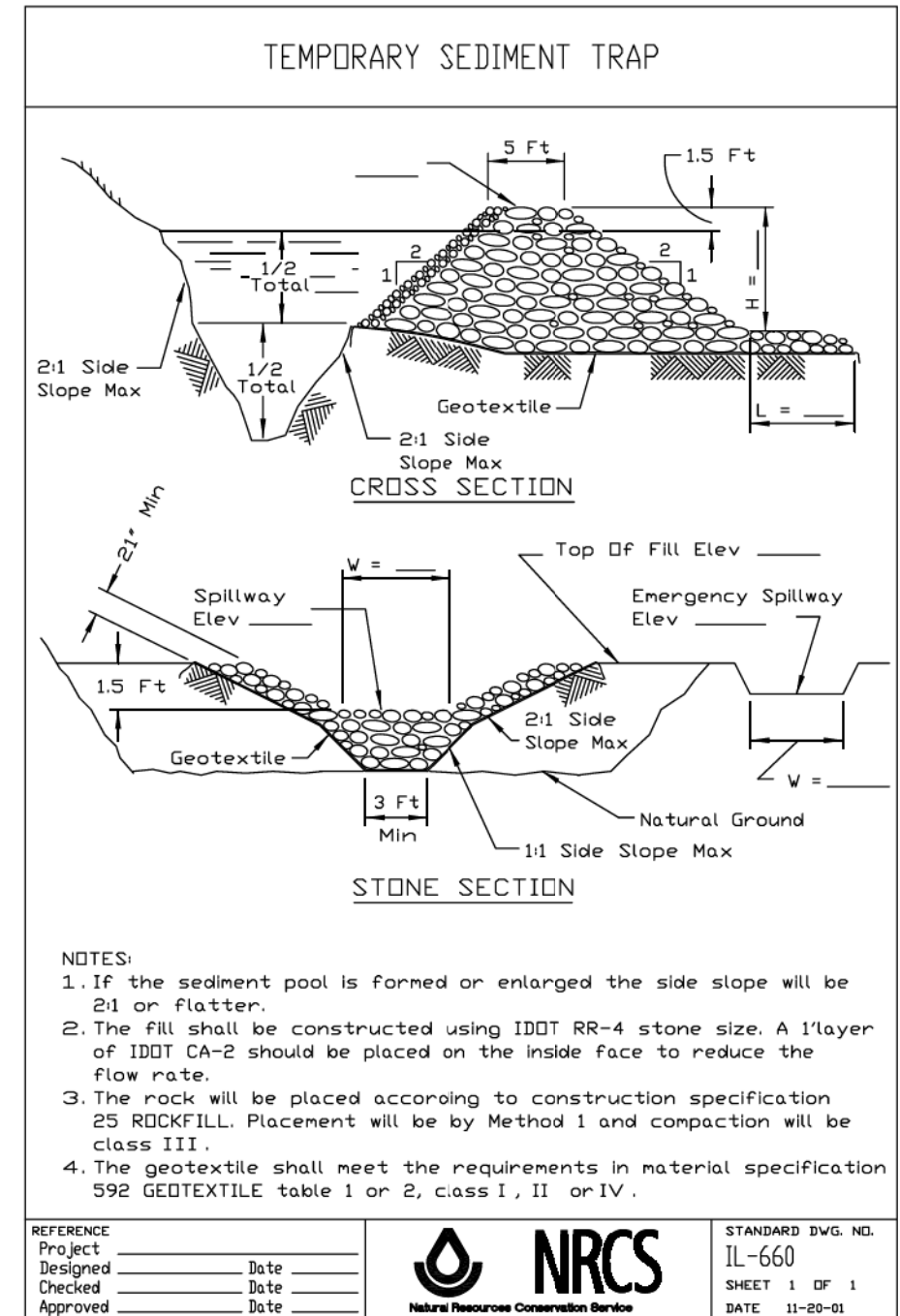
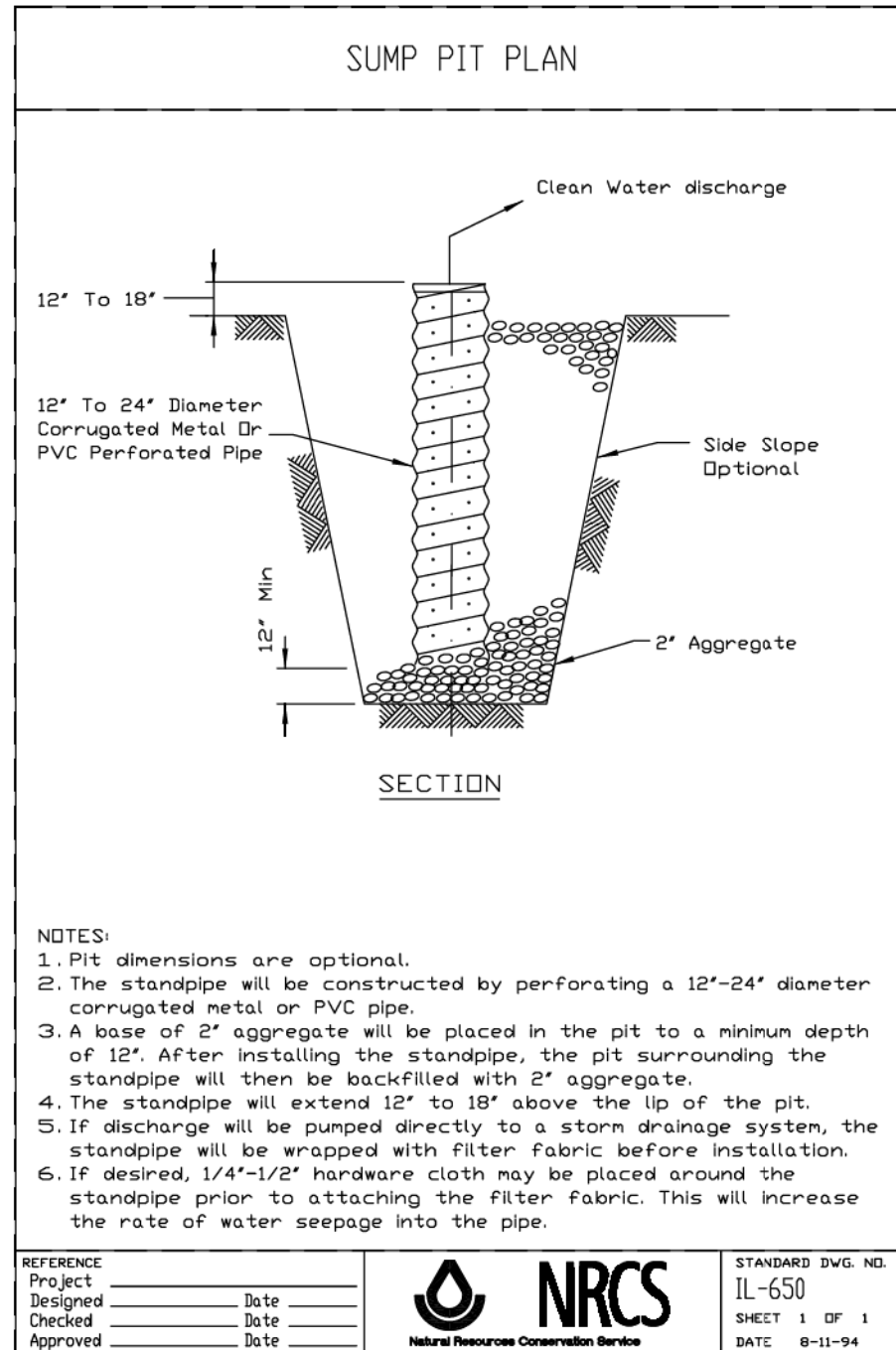

- NOTES:**
- A TEMPORARY SUMP PIT OR TEMPORARY SEDIMENT TRAP SHALL BE PROVIDED AND DESIGNED BY THE CONTRACTOR TO COLLECT THE OUTFLOW FROM THE TEMPORARY DRAINAGE SYSTEM BEFORE THE WATER ENTERS THE STORM SEWER SYSTEM. THE SUMP PIT OR TEMPORARY SEDIMENT TRAP SHALL FOLLOW THE REQUIREMENTS SHOWN ON THESE DETAILS. ALL OF THE WORK AND MATERIALS SHALL BE INCLUDED IN THE COST OF TEMPORARY DRAINAGE SYSTEM.



D160X78-sht-Eros-Detail-01.dgn
USER NAME = chiuw
PLOT SCALE = 100.0000' / in.
PLOT DATE = 3/20/2016

DESIGNED - AFC
DRAWN - AFC
CHECKED - DBM
DATE - 3/18/2016

REVISED -
REVISED -
REVISED -
REVISED -

**STATE OF ILLINOIS
DEPARTMENT OF TRANSPORTATION**

**EROSION CONTROL DETAILS
SUMP PIT AND TEMPORARY SEDIMENT TRAP**

SCALE: NTS SHEET 1 OF 2 SHEETS STA. TO STA.

F.A.I. RTE.	SECTION	COUNTY	TOTAL SHEETS	SHEET NO.
90/94/290	2014-004R&B	COOK	706	121
CONTRACT NO. 60X78				
ILLINOIS FED. AID PROJECT				

FILE PATH = p:\61779-PMINT\pccommon\line\local\AECOM_D902_NA\Documents\01_Americas\T\engproj\station\60269938_Circle\Phase_11\000_CAD\006_Roadway\Sheets\60x78_Contract\0160x78-sht-Eros-Detail-02

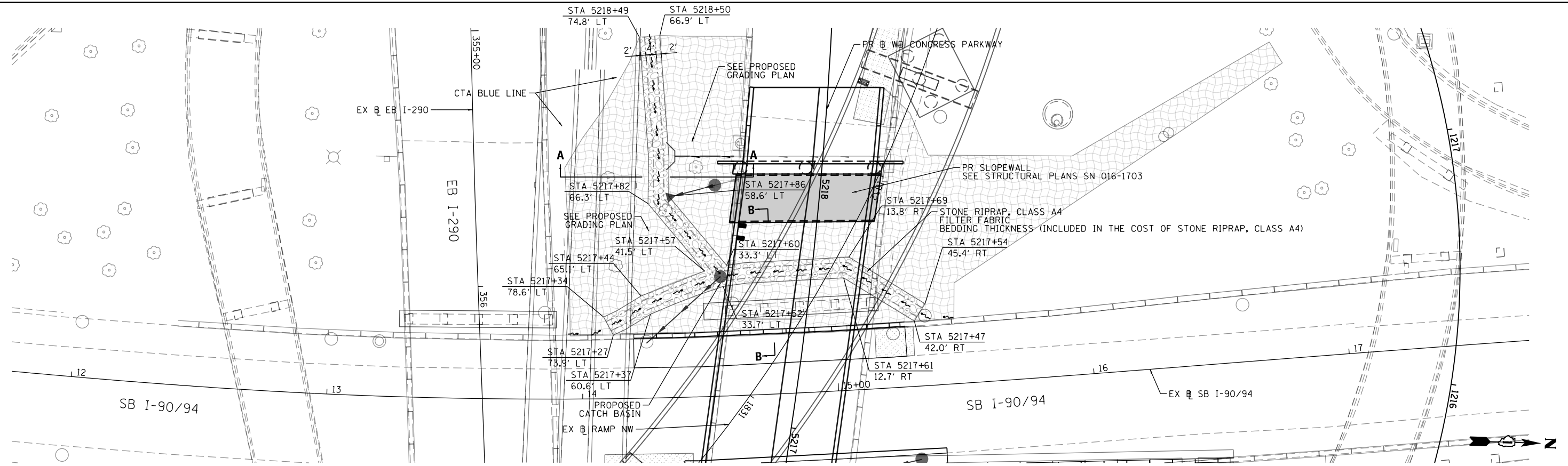

PLAN VIEW

NOTES:
 1. ALL STATIONINGS ARE BASED ON PROPOSED WB CONGRESS PARKWAY UNLESS OTHERWISE NOTED.

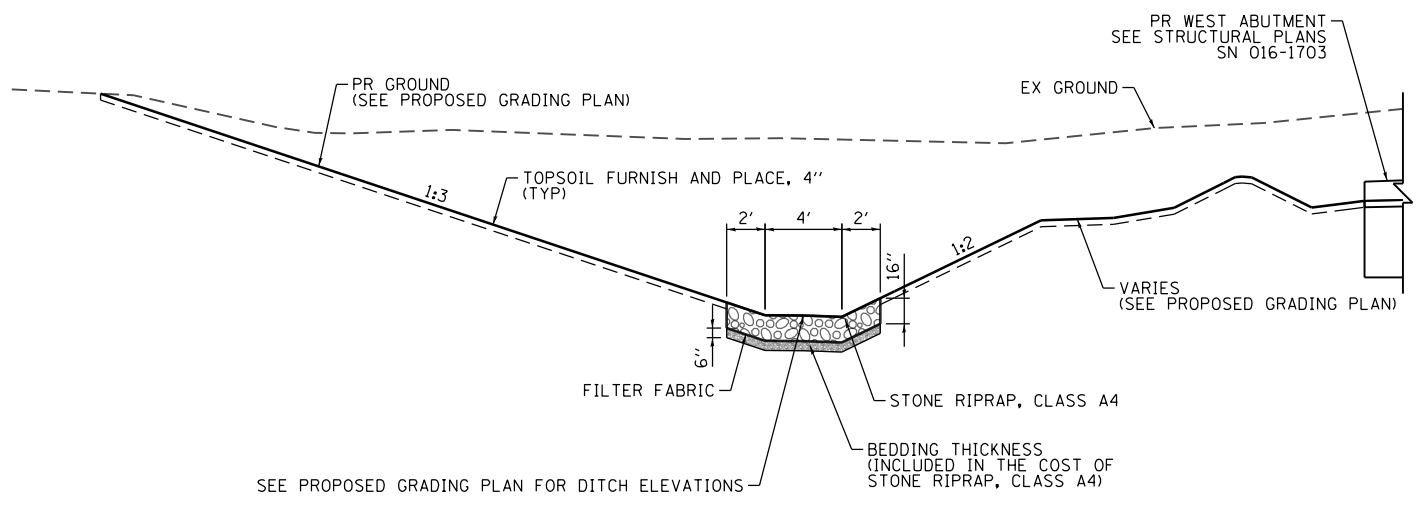
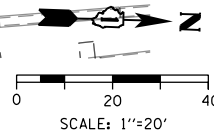

SECTION A-A
N.T.S.

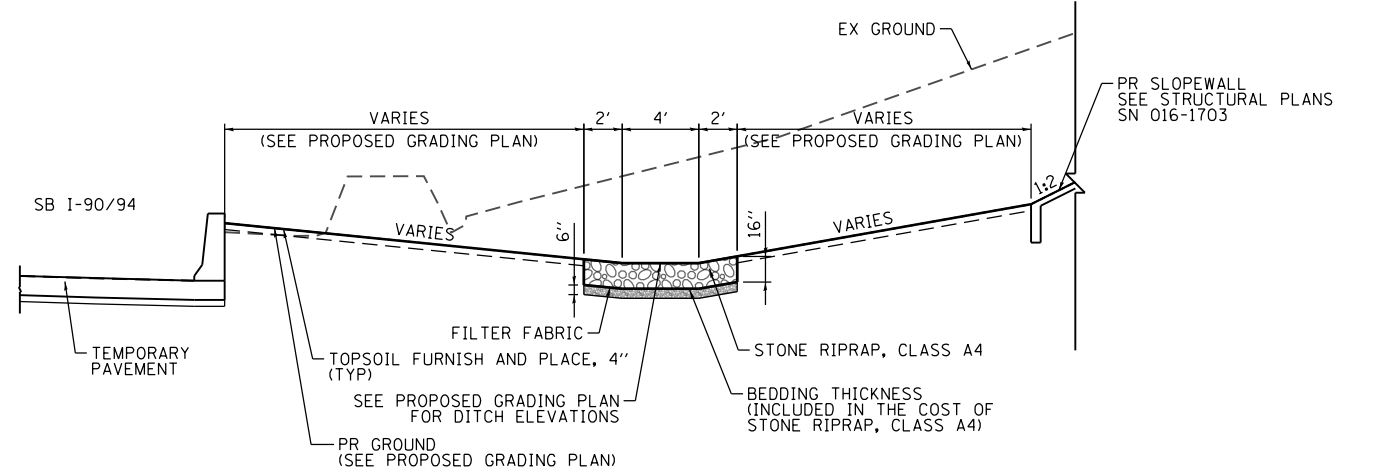

SECTION B-B
N.T.S.



D160x78-sht-Eros-Detail-02
 USER NAME = chiue
 PLOT SCALE = 40.0000' / in.
 PLOT DATE = 3/21/2016

DESIGNED - AFC
 DRAWN - AFC
 CHECKED - DBM
 DATE - 3/18/2016

REVISED -
 REVISED -
 REVISED -
 REVISED -

STATE OF ILLINOIS
DEPARTMENT OF TRANSPORTATION

EROSION CONTROL DETAILS
STONE RIPRAP

SCALE: 1" = 20' SHEET 2 OF 2 SHEETS STA. TO STA.

F.A.I. RTE.	SECTION	COUNTY	TOTAL SHEETS	SHEET NO.
90/94/290	2014-004R&B	COOK	706	122
CONTRACT NO. 60X78				
ILLINOIS FED. AID PROJECT				

DRAINAGE AND UTILITIES GENERAL NOTES

1. PRIOR TO BEGINNING CONSTRUCTION, THE CONTRACTOR MUST FIELD VERIFY HORIZONTAL AND VERTICAL POSITION OF ALL EXISTING UTILITIES.
2. SEE LIGHTING AND ITS PLANS FOR ADDITIONAL UTILITY INFORMATION.
3. FOR LOCATIONS WHERE THE PROPOSED PIPE IS TO CONNECT TO AN EXISTING PIPE, A CONCRETE COLLAR SHALL BE PROVIDED ACCORDING TO IDOT DISTRICT 1 STANDARD BD-07.
4. SEE STRUCTURAL PLANS FOR DRAINAGE SCUPPER LOCATIONS AND DRAINAGE SYSTEM DETAILS ON THE WESTBOUND I-290 BRIDGE OVER I-90/94 (SN 016-1703), WESTBOUND CONGRESS VIADUCT (SN 016-0461) AND RETAINING WALL 44 (SN 016-1831).
5. THE LOCATIONS OF EXISTING DRAINAGE STRUCTURES, STORM SEWERS AND/OR COMBINED SEWERS UNDERNEATH THE WESTBOUND CONGRESS VIADUCT (SN 016-0461) ARE APPROXIMATED AND BASED ON RECORD DRAWINGS. SOME OF THE EXISTING DRAINAGE STRUCTURES MAY BE BURIED. IT SHALL BE THE CONTRACTOR'S RESPONSIBILITY TO VERIFY ALL EXISTING CONDITIONS.
6. THE CONTRACTOR SHALL VERIFY THE PIPE ELBOW ANGLE SHOWN ON THE PLANS PRIOR TO THE ORDERING OF MATERIAL.
7. THE CONTRACTOR SHALL VERIFY ALL DIMENSIONS AND CONDITIONS IN THE FIELD PRIOR TO CONSTRUCTION AND ORDERING OF MATERIALS.
8. DRAINAGE GRADES SHALL BE VERIFIED IN FIELD PRIOR TO INSTALLATION OF DRAINAGE ITEMS.
9. THE CONTRACTOR IS RESPONSIBLE FOR MAINTAINING POSITIVE DRAINAGE ON JOB SITE DURING CONSTRUCTION.
10. EXCEPT WHERE DESIGNATED OTHERWISE, THE LOCATIONS AND/OR DEPTHS OF UNDERGROUND UTILITIES SHOWN HAVE BEEN TAKEN FROM OFFICE RECORD INFORMATION FURNISHED BY THE UTILITY OWNERS AND THE SUE SURVEYS. ALL UNDERGROUND UTILITIES MUST BE CONSIDERED APPROXIMATE.
11. THE CONTRACTOR SHALL BE RESPONSIBLE FOR THE PROTECTION OF ALL UNDERGROUND OR SURFACE UTILITIES EVEN THOUGH THEY MAY NOT BE SHOWN IN THE PLANS. ANY UTILITY THAT IS DAMAGED DURING CONSTRUCTION SHALL BE REPAIRED OR REPLACED TO THE SATISFACTION OF THE ENGINEER. THIS WORK WILL BE AT THE CONTRACTOR'S EXPENSE.
12. THE CONTRACTOR SHALL COORDINATE WORK WITH RAILROADS AND UTILITIES IN ADVANCE OF WORKING IN THE VICINITY OF THEIR FACILITIES AND ALLOW SUFFICIENT TIME FOR THEM TO PERFORM ADJUSTMENTS TO THEIR FACILITIES IN ACCORDANCE WITH THE CONTRACTOR'S SCHEDULE. THIS WORK WILL BE AT THE CONTRACTOR'S EXPENSE. COORDINATION EFFORTS SHALL BE INCLUDED IN THE COST OF THE CONTRACT BID PRICE.
13. THE OFFSETS AND TOP OF FRAME OR LID ELEVATIONS FOR DRAINAGE STRUCTURES WERE DETERMINED USING THE CRITERIA LISTED BELOW UNLESS OTHERWISE NOTED:
 - A. THE OFFSETS TO ALL INLETS AND CATCH BASINS IN ROADWAYS WITH BARRIER WALL ARE TO THE EDGE OF SHOULDER.
 - B. THE OFFSETS TO ALL INLETS AND CATCH BASINS IN CURBED ROADWAYS ARE TO THE EDGE OF PAVEMENT OR EDGE OF SHOULDER. STRUCTURES LOCATED IN THE GUTTER SHALL BE TURNED SO THAT THE FRAME IS FURTHEST FROM THE CENTER LINE OF THE ROAD UNLESS OTHERWISE NOTED ON THE PLANS.
 - C. THE OFFSETS TO MANHOLES, STRUCTURES IN CORE AREAS, AND STRUCTURES IN INFIELD AREAS ARE TO THE CENTER OF THE STRUCTURE.
 - D. THE OFFSETS TO INLETS AND CATCH BASINS IN CONCRETE GUTTER ARE TO BE THE FLOWLINE.
14. STORM SEWER (WATER MAIN REQUIREMENTS) IS TO BE USED AT LOCATIONS WHERE LATERAL SEPARATION BETWEEN THE SEWER AND WATER MAIN IS LESS THAN 10 FT AND THE VERTICAL SEPARATION IS LESS THAN 1.5 FT. DUCTILE IRON PIPE WITH RUBBER GASKET JOINTS SHALL BE USED FOR ALL STORM SEWERS (WATER MAIN REQUIREMENTS).

15. CONNECTING EXISTING DRAINAGE SYSTEMS TO PROPOSED DRAINAGE SYSTEMS SHALL BE INCLUDED IN THE COST OF THE PROPOSED DRAINAGE ITEMS. CARE SHALL BE TAKEN BY THE CONTRACTOR TO NOT DAMAGE THE EXISTING DRAINAGE SYSTEMS. ANY DAMAGE CAUSED BY THE CONTRACTOR TO THE EXISTING DRAINAGE SYSTEMS SHALL BE REPAIRED OR REPLACED BY THE CONTRACTOR AT THE CONTRACTOR'S OWN EXPENSE AND TO THE SATISFACTION OF THE ENGINEER. NO ADDITIONAL COMPENSATION SHALL BE PROVIDED.
16. ALL PROPOSED PIPE CONNECTIONS INTO AN EXISTING DRAINAGE STRUCTURE SHALL BE CORE DRILLED AND INCLUDED IN THE COST OF STORM SEWERS OR DRAINAGE SYSTEM.
17. FOR STORM SEWER CONSTRUCTED UNDER THE ROADWAY, BACKFILLING METHODS TWO AND THREE AUTHORIZED UNDER THE PROVISIONS OF ARTICLE 550.07 OF THE STANDARD SPECIFICATIONS WILL NOT BE ALLOWED.
18. ABANDONED UNDERGROUND UTILITIES THAT CONFLICT WITH CONSTRUCTION SHALL BE DISPOSED OF OUTSIDE THE LIMITS OF THE RIGHT-OF-WAY ACCORDING TO ART. 202.03 OF THE STANDARD SPECIFICATIONS AND AS DIRECTED BY THE ENGINEER. THIS WORK WILL NOT BE PAID FOR SEPARATELY BUT WILL BE INCLUDED IN THE COST OF EARTH EXCAVATION.
19. ANY DAMAGES TO THE CONDUITS OR PIPES CAUSED BY THE CONTRACTOR'S OPERATIONS SHALL BE REPLACED OR REPAIRED BY THE CONTRACTOR AT HIS/HER EXPENSE.
20. THE CONTRACTOR MUST CALL THE IDOT ELECTRICAL MAINTENANCE CONTRACTOR TO LOCATE IDOT FACILITY CABLES.
21. A QUANTITY OF 100 FEET OF EXPLORATION TRENCH 72" DEPTH HAS BEEN INCLUDED IN THE PLANS FOR THE PURPOSE OF PHYSICALLY LOCATING ANY UTILITY OR OBSTRUCTION. THE ENGINEER SHALL APPROVE THE LOCATIONS OF THE EXPLORATION TRENCH 72" DEPTH BEFORE ANY EXCAVATION MAY BEGIN.

METROPOLITAN WATER RECLAMATION DISTRICT OF GREATER CHICAGO (MWRD) DRAINAGE AND UTILITIES GENERAL NOTES

1. THE FACILITIES OF METROPOLITAN WATER RECLAMATION DISTRICT OF GREATER CHICAGO (MWRD) SHALL BE LOCATED PRIOR TO PROCEEDING WITH ANY CONSTRUCTION WORK.
2. A MINIMUM HORIZONTAL AND VERTICAL CLEARANCE OF TWO FEET SHALL BE MAINTAINED BETWEEN THE MWRD SEWER AND THE PROPOSED WORK.
3. DURING CONSTRUCTION, EXTRA CAUTION SHALL BE TAKEN TO PROTECT THE SAFETY AND INTEGRITY OF MWRD FACILITIES.
4. NO ACCESS HATCHES AND MANHOLE COVERS ON MWRD STRUCTURES AND MANHOLES WITHIN THE PROJECT AREA SHALL BE BURIED OR COVERED.
5. NO DEBRIS SHALL ENTER MWRD STRUCTURES, SEWERS, OR FACILITIES.
6. MWRD PERSONNEL SHALL HAVE 24 HOUR-A-DAY UNRESTRICTED ACCESS TO ALL MWRD FACILITIES.

CITY OF CHICAGO DRAINAGE AND UTILITIES GENERAL NOTES

1. THE LOCATIONS AND ELEVATIONS OF EXISTING SEWERS AND SEWER STRUCTURES SHOWN ON THE PLANS AND PROFILES HAVE BEEN OBTAINED FROM DRAWINGS AND ATLASES AND THE INFORMATION IS NOT GUARANTEED. THE ENGINEER AND THE CONTRACTOR SHALL FIELD VERIFY THE CITY'S EXISTING SEWER FACILITIES INCLUDING PUBLIC AND PRIVATE DRAIN CONNECTIONS IN THE LIMITS OF THE REFERENCED PROJECT FOR ANY CONFLICTS DUE TO THE PROPOSED IMPROVEMENTS. ANY CONFLICT SHOULD BE RESOLVED WITH THE DEPARTMENT OF WATER MANAGEMENT PRIOR TO START OF CONSTRUCTION.
2. IN LOCATIONS WHERE THE MAIN SEWER IS NOT BEING REPLACED AND THE EXISTING DRAINAGE FACILITIES ARE DISTURBED OR DAMAGED DURING CONSTRUCTION BY THE CONTRACTOR, IT WILL BE THE CONTRACTOR'S RESPONSIBILITY TO RESTORE AND REPLACE THE DAMAGED FACILITIES AT HIS/HER EXPENSE TO THE SATISFACTION OF THE DEPARTMENT OF WATER MANAGEMENT. THE SEWER FLOWS MUST BE MAINTAINED AT ALL TIMES.
3. IN CASE OF ANY DAMAGE TO THE CITY'S SEWER SYSTEM, PRIVATE AND PUBLIC DRAIN CONNECTIONS, THE CONTRACTOR SHALL CONTACT THE CHICAGO DEPARTMENT OF WATER MANAGEMENT IMMEDIATELY AT (312) 747-8117 OR (312) 747-7893. THE CONTRACTOR SHALL AT HIS/HER OWN EXPENSE, REPLACE THE AFFECTED SEWERS, DRAIN CONNECTIONS, AND SEWER STRUCTURES AS NECESSARY. THE SEWER FLOW MUST BE MAINTAINED AT ALL TIMES.
4. THERE ARE VARIOUS WATER MAINS AND APPURTENANCES WITHIN THE LIMITS OF THIS PROJECT. ALL PROPOSED ELECTRICAL FACILITIES MUST BE INSTALLED IN SUCH A MANNER TO PROVIDE A MINIMUM FIVE (5) FEET HORIZONTAL AND EIGHTEEN (18) INCHES VERTICAL CLEARANCE FROM ALL EXISTING WATER FACILITIES. NO PROPOSED ABOVE GROUND FACILITY (TREE, PLANTER BOX, LIGHT POLE, ETC.) CAN BE CLOSER THAN FIVE (5) FEET (EDGE-TO-EDGE) FROM A WATER MAIN, WATER SERVICE, OR WATER STRUCTURE.
5. CITY OF CHICAGO WATER VALVE VAULTS AND SEWER STRUCTURES SHALL NOT BE CLOSED, COVERED OR OTHERWISE OBSTRUCTED DURING CONSTRUCTION WITHOUT WRITTEN PERMISSION FROM THE CITY OF CHICAGO DEPARTMENT OF WATER MANAGEMENT UNLESS SPECIFICALLY IDENTIFIED FOR REMOVAL, RECONSTRUCTION, OR ADJUSTMENT WITHIN THESE PLANS.
6. AS-BUILT PLANS MUST BE SUBMITTED RIGHT AFTER WORK COMPLETION. FINAL PAYMENT SHALL NOT BE MADE TO THE CONTRACTOR UNTIL THE DEPARTMENT OF WATER MANAGEMENT ACKNOWLEDGES RECEIPT OF AS-BUILT PLANS.
7. ALL PROPOSED SEWER CONNECTIONS MUST MEET I.E.P.A. HORIZONTAL AND VERTICAL SEPARATION REQUIREMENTS WHEN CROSSING UNDER OR PARALLEL TO EXISTING WATER MAINS.
8. ALL EXISTING FIRE HYDRANTS WITHIN THE PROPOSED IMPROVEMENT LIMITS MUST REMAIN VISIBLE AND ACCESSIBLE SO THAT EMERGENCY PERSONNEL AND VEHICLES CAN ACCESS THE EXISTING HYDRANTS AT ANY TIME.
9. IF CONSTRUCTION REQUIRES THE USE OF WATER FROM A CITY FIRE HYDRANT, OR ADJUSTMENTS OR REPAIRS ARE REQUIRED TO ANY CITY SEWER FACILITIES IN PROXIMITY TO THE PROJECT SITE, PERMITS MUST BE OBTAINED FROM THE CDWM, WATER, AND SEWER SECTIONS.
10. THERE ARE NUMEROUS MANHOLES, CATCH BASINS, AND INLETS WHICH MUST BE PROTECTED FROM ENTRY OF ASPHALT/DEBRIS INTO THE SEWER SYSTEM DURING CONSTRUCTION. THE CONTRACTOR SHALL MARK LOCATIONS OF ALL SEWER STRUCTURES ON THE SIDEWALK BEFORE STARTING PAVEMENT REMOVAL/REPLACEMENT. ALL NECESSARY ADJUSTMENTS TO SEWER FACILITIES, INCLUDING VERTICAL ADJUSTMENT OF FRAMES AND LIDS, SHALL BE INCLUDED IN THE CONTRACT AND PERFORMED BY THE CONTRACTOR PRIOR TO STREET RESURFACING. PLEASE CONTACT THOMAS MENDOZA AT THOMAS.MENDOZA@CITYOFCHICAGO.ORG OR AT (312) 747-4680 REGARDING FINAL INSPECTION OF ALL SEWER FACILITIES.
11. A PERMIT FROM THE CDWM SHOULD BE OBTAINED IN ADVANCE FOR ANY UNDERGROUND SEWER WORK INCLUDING ADJUSTMENT OF STRUCTURES, REMOVAL OR REPLACEMENT OF FRAMES AND LIDS, TELEVISION SURVEYS, CLEANING, LINING AND INSPECTIONS BY A LICENSED SEWER CONTRACTOR AT 333 S. STATE STREET, SUITE 410, CHICAGO, ILLINOIS 60604.

FILE PATH = P:\60288727\000_CAD\006_Roadway\Printing\60288727\2016-03-18_F.mel_Plot_Export\0160288727-sht-Drain-Notes.dgn



0160288727-sht-Drain-Notes.dgn	DESIGNED - AFC	REVISED -
USER NAME = chiuo	DRAWN - AFC	REVISED -
PLOT SCALE = 100.0000' / in.	CHECKED - MSC	REVISED -
PLOT DATE = 3/20/2016	DATE - 3/18/2016	REVISED -

**STATE OF ILLINOIS
DEPARTMENT OF TRANSPORTATION**

DRAINAGE AND UTILITIES GENERAL NOTES

SCALE: NTS SHEET 1 OF 1 SHEETS STA. TO STA.

F.A.I. RTE.	SECTION	COUNTY	TOTAL SHEETS	SHEET NO.
90/94/290	2014-004R&B	COOK	706	123
CONTRACT NO. 60X78			ILLINOIS FED. AID PROJECT	

FILE PATH = p:\617479-PMINT\secomon\line\local\AECOM\0902_NA\Documents\01_Americas\T\enqor\station\602694938_Circle\Phase_11\000_CAD\006_Roadway\Sheets\60x78_Contract\0160x78-Sht-Drain-01.dgn

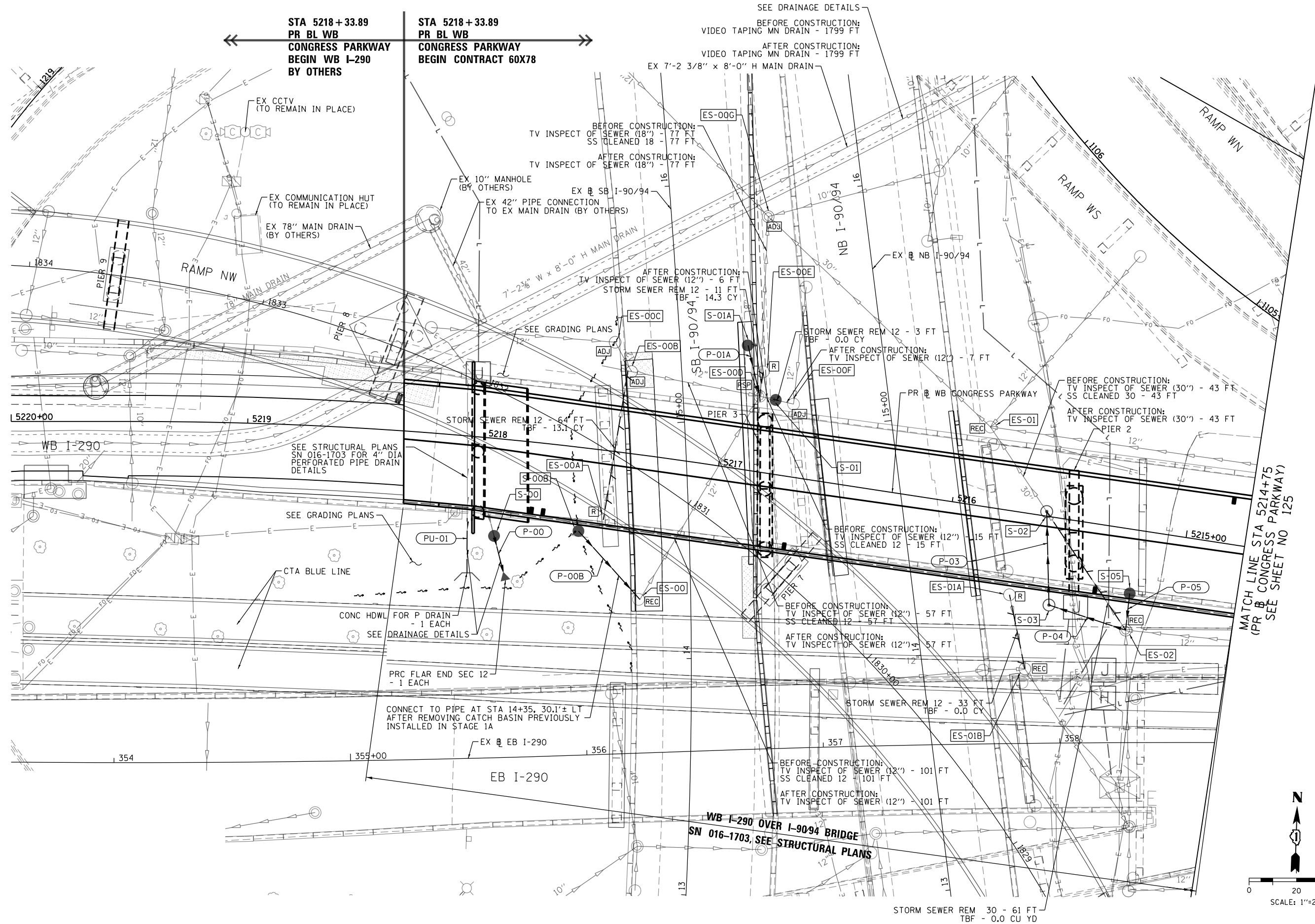

MATCH LINE STA 5214+75
(PR B CONGRESS PARKWAY)
SEE SHEET NO 125

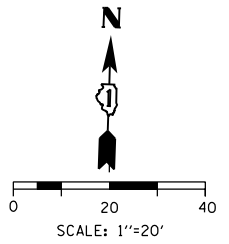

D160x78-Sht-Drain-01.dgn
USER NAME = dshevoz
PLOT SCALE = 40.0000' / in.
PLOT DATE = 4/27/2016

DESIGNED - AFC	REVISED -
DRAWN - ZND	REVISED -
CHECKED - EY	REVISED -
DATE - 3/18/2016	REVISED -

**STATE OF ILLINOIS
DEPARTMENT OF TRANSPORTATION**

**DRAINAGE AND UTILITY PLAN
WB CONGRESS PARKWAY**

SCALE: 1" = 20' SHEET 1 OF 4 SHEETS STA. 5220+00 TO STA. 5214+75

F.A.I. R.T.E. 90/94/290	SECTION 2014-004R&B	COUNTY COOK	TOTAL SHEETS 706	SHEET NO. 124
CONTRACT NO. 60X78				
ILLINOIS FED. AID PROJECT				

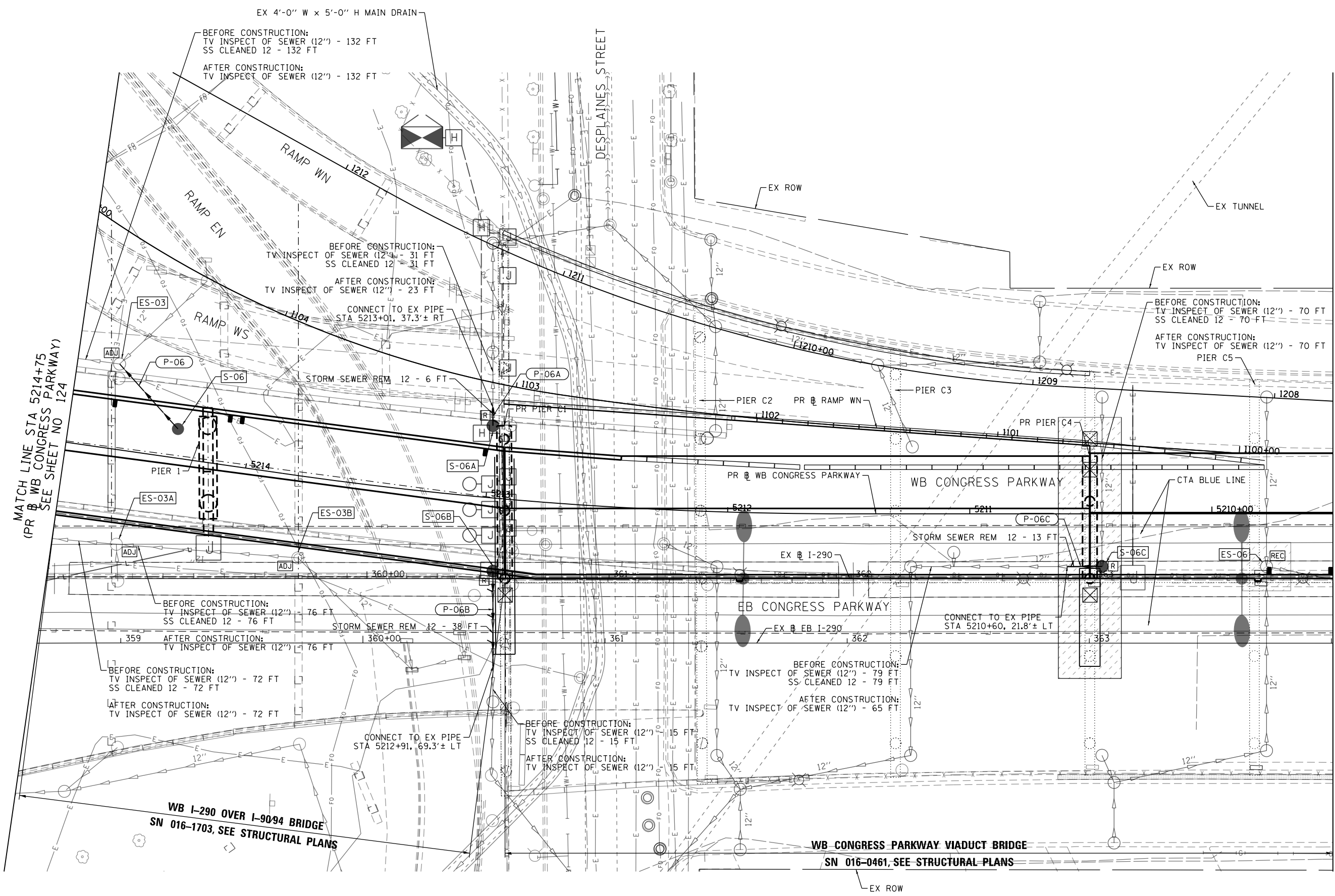
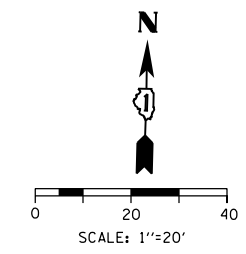

MATCH LINE STA 5214+75
(PR WB CONGRESS PARKWAY)
SEE SHEET NO 124

MATCH LINE STA 5209+50
(PR WB CONGRESS PARKWAY)
SEE SHEET NO 126

WB I-290 OVER I-90/94 BRIDGE
SN 016-1703, SEE STRUCTURAL PLANS

WB CONGRESS PARKWAY VIADUCT BRIDGE
SN 016-0461, SEE STRUCTURAL PLANS

FILE PATH = p:\617479-PMINT\pccom\line\local\AECOM_D902_MIA\Documents\01_Americas\T\engor\station\60269938_Circle\Phase_11\000_CAD\006_Roadway\Sheets\60x78_Contract\016078-sht-Drain-02



D160X78-sht-Drain-02
USER NAME = chiue
PLOT SCALE = 40.0000' / in.
PLOT DATE = 3/21/2016

DESIGNED - AFC	REVISED -
DRAWN - ZND	REVISED -
CHECKED - EY	REVISED -
DATE - 3/18/2016	REVISED -

STATE OF ILLINOIS
DEPARTMENT OF TRANSPORTATION

DRAINAGE AND UTILITY PLAN
WB CONGRESS PARKWAY

SCALE: 1" = 20' SHEET 2 OF 4 SHEETS STA. 5214+75 TO STA. 5209+50

F.A.I. RTE. 90/94/290	SECTION 2014-004R&B	COUNTY COOK	TOTAL SHEETS 706	SHEET NO. 125
CONTRACT NO. 60X78			ILLINOIS FED. AID PROJECT	

FILE PATH = p:\61779-PMINT\pccom\line\local\AECOM_D902_NA\Documents\01_Americas\T\engpccom\station\60269938_Circle\Phase_11\000_CAD\006_Roadway\Sheets\60x78_Contract\0160x78-sht-Drain-03

MATCH LINE STA 5209+50
(PR B WB CONGRESS PARKWAY)
SEE SHEET NO 125

MATCH LINE STA 5203+75
(PR B WB CONGRESS PARKWAY)
SEE SHEET NO 127

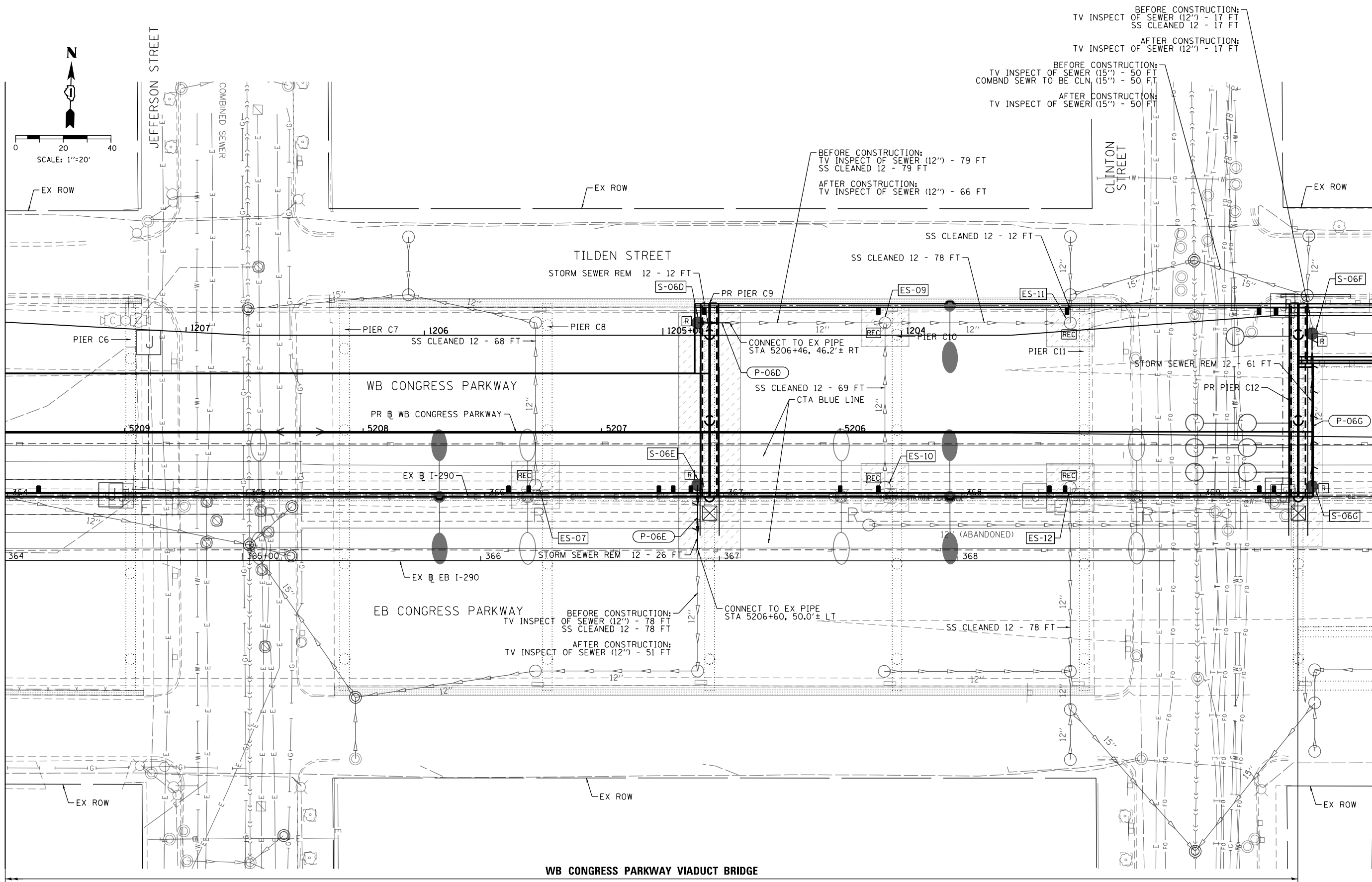

WB CONGRESS PARKWAY VIADUCT BRIDGE
SN 016-0461, SEE STRUCTURAL PLANS



D160x78-sht-Drain-03
USER NAME = chiuw
PLOT SCALE = 40.0000' / in.
PLOT DATE = 3/21/2016

DESIGNED - AFC	REVISED -
DRAWN - ZND	REVISED -
CHECKED - EEY	REVISED -
DATE - 3/18/2016	REVISED -

STATE OF ILLINOIS
DEPARTMENT OF TRANSPORTATION

DRAINAGE AND UTILITY PLAN
WB CONGRESS PARKWAY

SCALE: 1" = 20' SHEET 3 OF 4 SHEETS STA. 5209+50 TO STA. 5203+75

F.A.I. RTE.	SECTION	COUNTY	TOTAL SHEETS	SHEET NO.
90/94/290	2014-004R&B	COOK	706	126
CONTRACT NO. 60X78				
ILLINOIS FED. AID PROJECT				

FILE PATH = p:\61779-PMINT\pccommon\line\local\AECOM_D592_NA\Documents\01_Americas\T_eng\pccommon\line\60269938_Circle\Phase_11\000_CAD\006_Roadway\Sheets\60X78_Contract\0160X78-sht-Drain-04

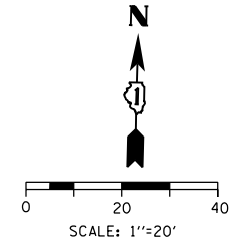
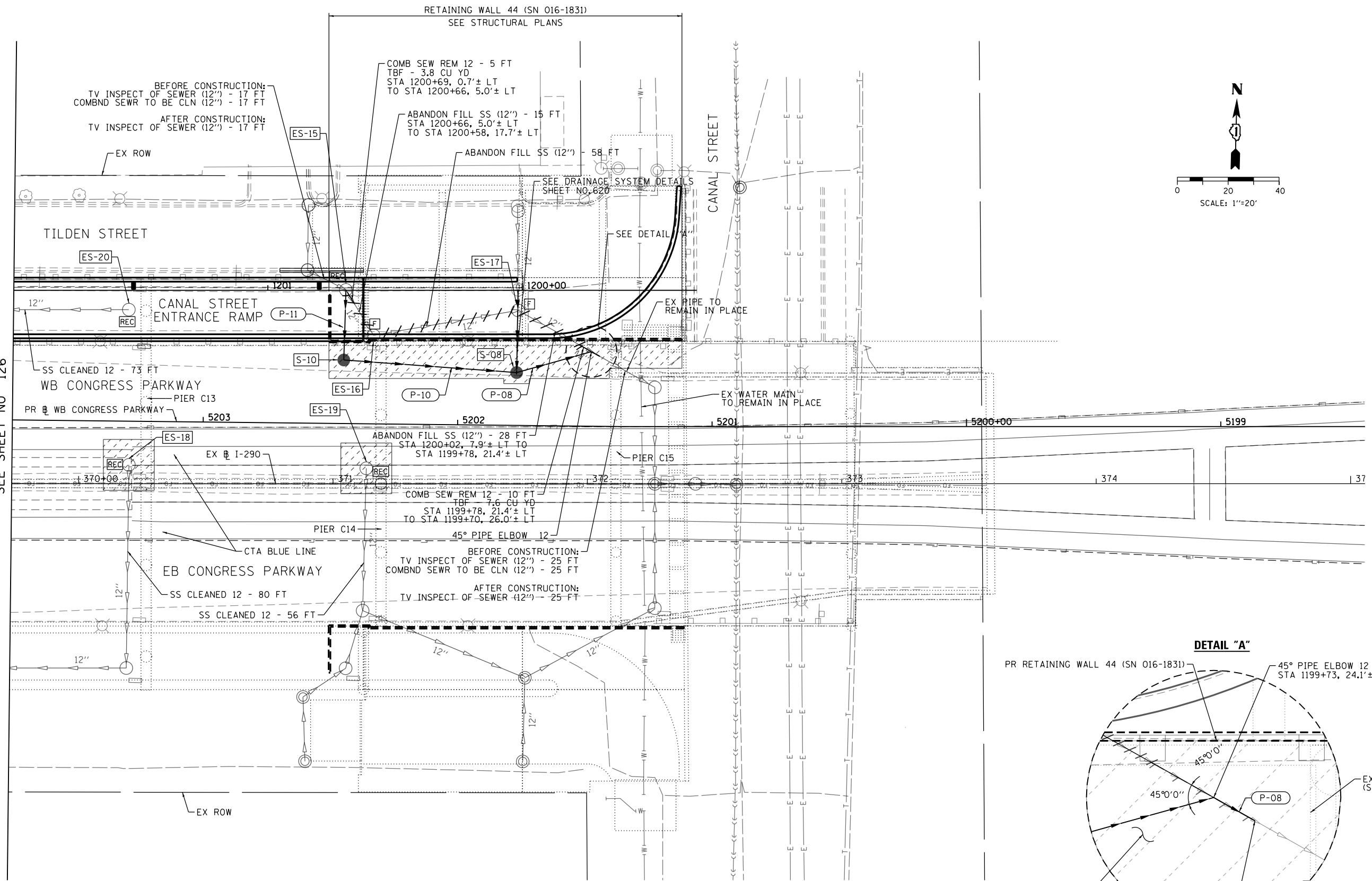

MATCH LINE STA 5203+75
(PR WB CONGRESS PARKWAY)
SEE SHEET NO 126

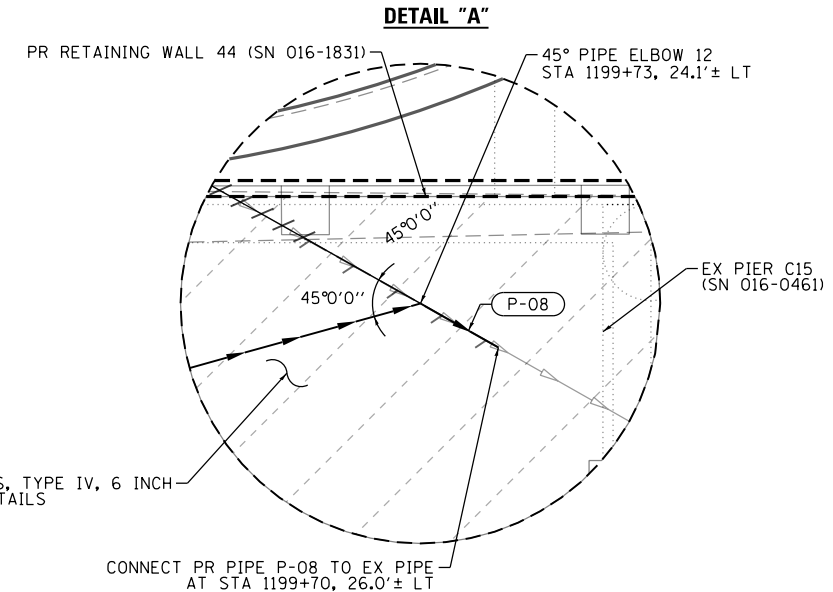

D160X78-sht-Drain-04
USER NAME = chiue
PLOT SCALE = 40.0000' / in.
PLOT DATE = 3/21/2016

DESIGNED - AFC	REVISED -
DRAWN - ZND	REVISED -
CHECKED - EEE	REVISED -
DATE - 3/18/2016	REVISED -

STATE OF ILLINOIS
DEPARTMENT OF TRANSPORTATION

DRAINAGE AND UTILITY PLAN
WB CONGRESS PARKWAY

SCALE: 1" = 20' SHEET 4 OF 4 SHEETS STA.5203+75 TO STA.5200+00

F.A.I. RTE.	SECTION	COUNTY	TOTAL SHEETS	SHEET NO.
90/94/290	2014-004R&B	COOK	706	127
CONTRACT NO. 60X78				
ILLINOIS FED. AID PROJECT				

PLAN	SURVEYED	BY	DATE
	PLOTTED		
	GRADES CHECKED		
	ALIGNMENT CHECKED		
	STRUCTURE NOTATIONS CHKD		
	NO.		
	NOTE BOOK		
	CARD FILE NAME		

PROFILE	SURVEYED	BY	DATE
	PLOTTED		
	GRADES CHECKED		
	ALIGNMENT CHECKED		
	STRUCTURE NOTATIONS CHKD		
	NO.		
	NOTE BOOK		
	CARD FILE NAME		

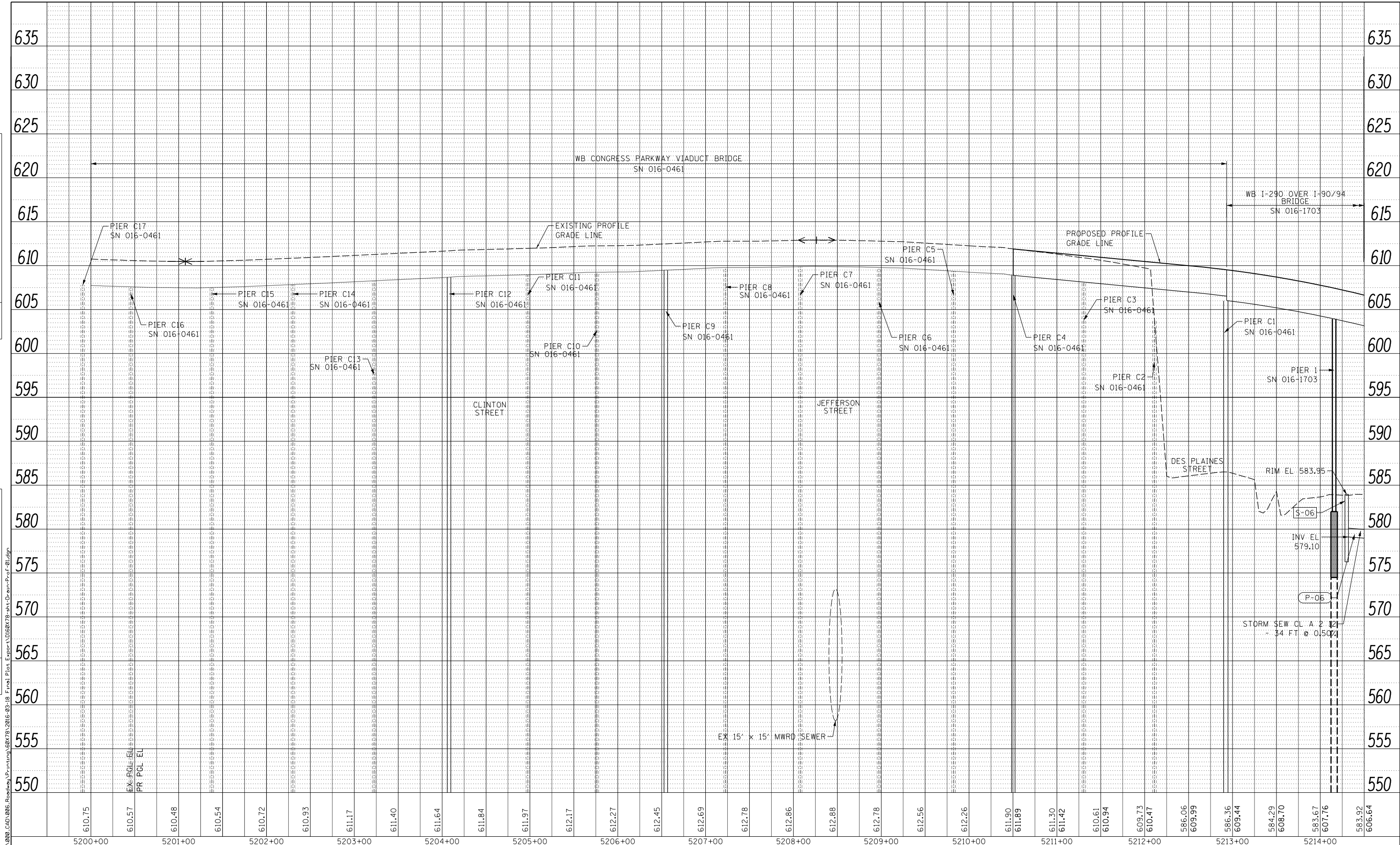

D160X78-sht-Drain-Prof-01.dgn
 USER NAME = chiue
 PLOT SCALE = 100.0000' / in.
 PLOT DATE = 3/20/2016

DESIGNED -	AFC	REVISED -	
DRAWN -	AFC	REVISED -	
CHECKED -	DBM	REVISED -	
DATE -	3/18/2016	REVISED -	

**STATE OF ILLINOIS
 DEPARTMENT OF TRANSPORTATION**

DRAINAGE AND UTILITY PROFILE
WB CONGRESS PARKWAY (PR BL WB CONGRESS)
 SCALE: 1"=50' SHEET 1 OF 2 SHEETS STA. TO STA.

F.A.I. RTE.	SECTION	COUNTY	TOTAL SHEETS	SHEET NO.
90/94/290	2014-004R&B	COOK	706	128
CONTRACT NO. 60X78				ILLINOIS FED. AID PROJECT

535

FILE PATH = P:\62088727\000_CAD\006_Roadway\Printing\60X78_2015_03_18_Final_Plot_Report\160X78-sht-Drain-Prof-01.dgn

PLAN	SURVEYED	DATE
	PLOTTED	
	ALIGNED	
	CHECKED	
	FILED	
	CARD FILE NAME	
	NO.	

PROFILE	SURVEYED	DATE
	CHECKED	
	GRADES	
	STRUCTURE	
	NOTATIONS	
	CHWD	
	NO.	

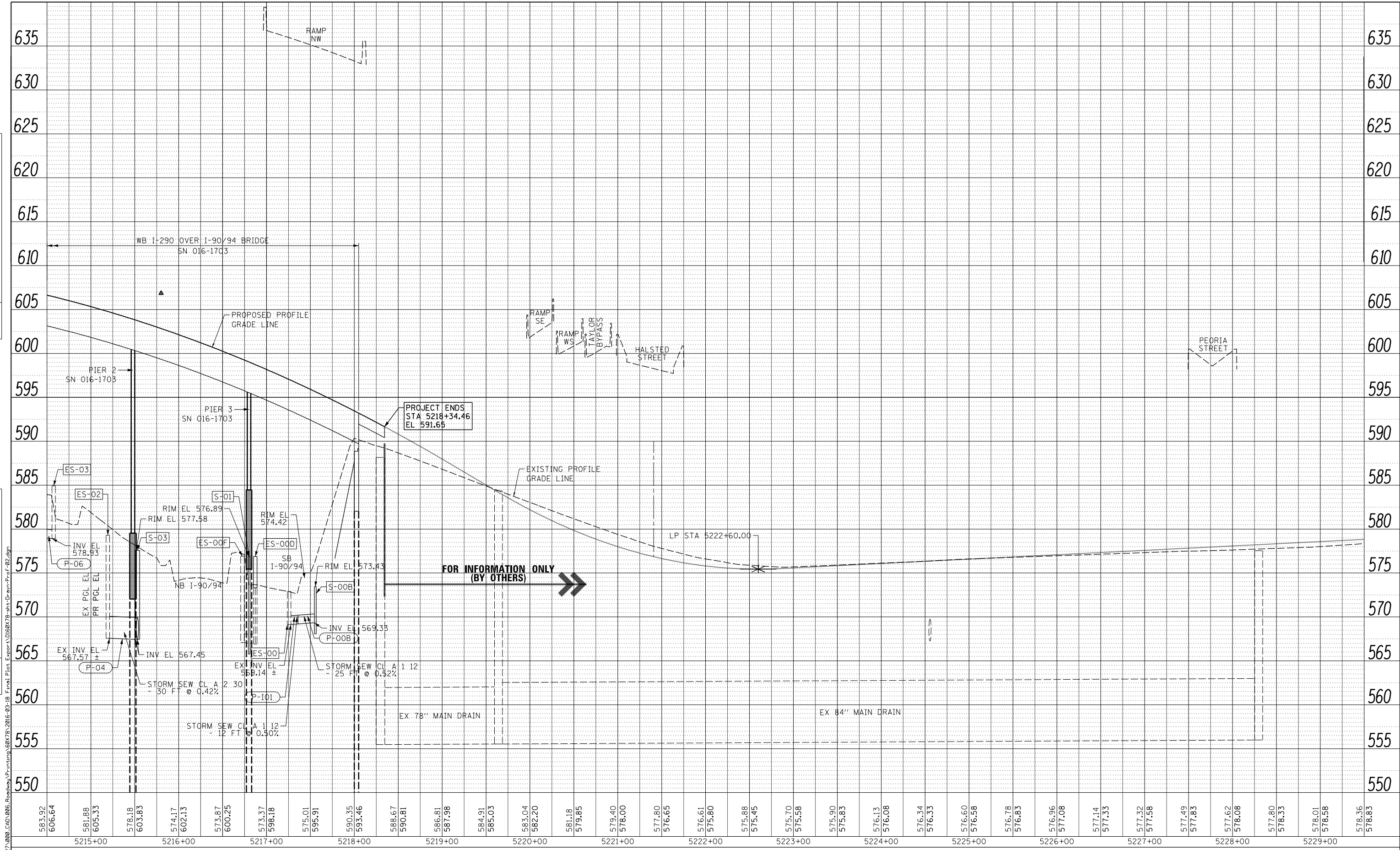

FILE PATH = P:\A6208272\000_CAD\006_Roadway\Printing\60x78\2015-03-18 Final Plot Export\0160x78-sht-Drain-Prof-02.dgn



D160x78-sht-Drain-Prof-02.dgn
 USER NAME = chiue
 PLOT SCALE = 100.0000' / in.
 PLOT DATE = 3/20/2016

DESIGNED - AFC	REVISED -
DRAWN - AFC	REVISED -
CHECKED - DBM	REVISED -
DATE - 3/18/2016	REVISED -

**STATE OF ILLINOIS
 DEPARTMENT OF TRANSPORTATION**

**DRAINAGE AND UTILITY PROFILE
 WB CONGRESS PARKWAY (PR BL WB CONGRESS)**

SCALE: 1"=50' SHEET 2 OF 2 SHEETS STA. TO STA.



F.A.I. RTE.	SECTION	COUNTY	TOTAL SHEETS	SHEET NO.
90/94/290	2014-004R&B	COOK	706	129
CONTRACT NO. 60X78				
ILLINOIS FED. AID PROJECT				

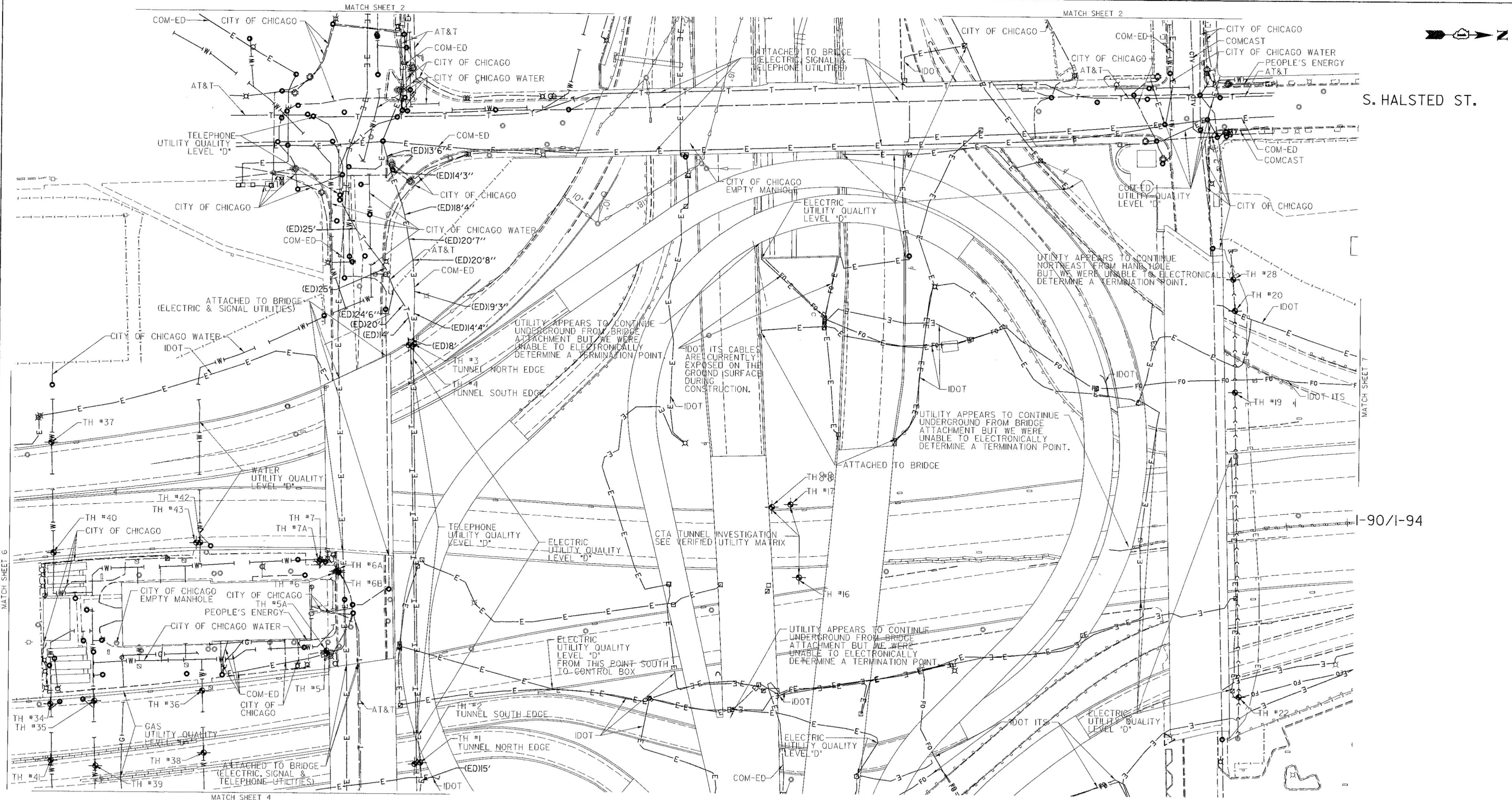

S. HALSTED ST.

I-90/I-94

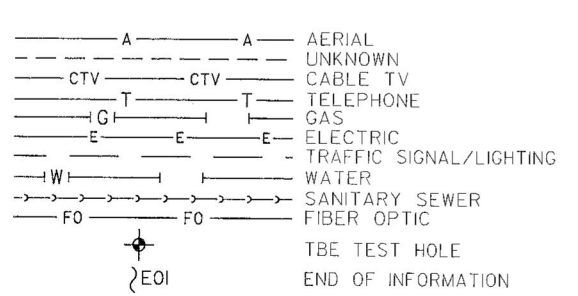

UTILITY OWNERS
 AT&T = TELEPHONE
 COM-ED = ELECTRIC
 CITY OF CHICAGO = ELECTRIC
 CITY OF CHICAGO WATER = WATER
 IDOT = ELECTRIC
 IDOT ITS = FIBER OPTIC
 PEOPLE'S ENERGY = GAS

NOTE: ALL ELECTRONIC DEPTHS MARKED AS (ED) WERE OBTAINED UTILIZING A SONDE DEVICE. DEPTHS ON THE AT&T DUCT WERE RECORDED FROM AN AT&T CONTRACTOR. DEPTHS ON THE COMED DUCT WERE RECORDED BY A CARDNO CREW. CARDNO CAN NOT VERIFY THE ACCURACY OF THESE DEPTHS AND SHOULD BE USED AS APPROXIMATE AND AS INFORMATION ONLY.

UTILITIES SHOWN ON THESE PLANS AS DEPICTED IN THE LEGEND HAVE BEEN INVESTIGATED BY CARDNO IN ACCORDANCE WITH SUE INDUSTRY STANDARDS. ALL OTHER INFORMATION SHOWN HAS BEEN PROVIDED TO CARDNO BY OTHERS. CARDNO SUE FIELD INVESTIGATION WAS PERFORMED 3/14/13 THROUGH 10/21/15. CHANGES TO UTILITIES MAY HAVE BEEN MADE AND THEREFORE MAY RESULT IN VARIANCES FROM THIS PLAN. CONSIDERATION SHOULD BE GIVEN TO UPDATING THIS PLAN IF DEEMED ADVISABLE PRIOR TO FINAL DESIGN AND CONSTRUCTION.

ALL UTILITIES SHOWN QUALITY LEVEL "B" UNLESS NOTED OTHERWISE.

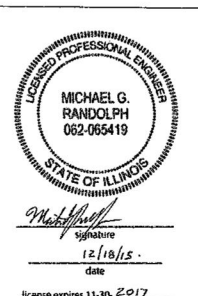

Utility Quality Level "A": Visually Verified Test Hole
 Utility Quality Level "B": Designating/non Visually Verified Test Hole
 Utility Quality Level "C": Research with Survey
 Utility Quality Level "D": Records Research

DESIGNED	IP	REVISED
DRAWN	SRK	REVISED
CHECKED	MGR	REVISED
DATE	12/18/15	REVISED

STATE OF ILLINOIS
 DEPARTMENT OF TRANSPORTATION

I-94-I-90-290 (Circle Interchange)
 Chicago, Illinois

F.A. RTE.	SECTION	COUNTY	TOTAL SHEETS	SHEET NO.
	N/A	Cook	706	130

Contract No. N/A
 FED. ROAD DIST. NO. ILLINOIS IDOT Project No. P-9-259-12

TBE Job No. IL0950531, 563, 647
 SUE Plan Page: 3 of 12

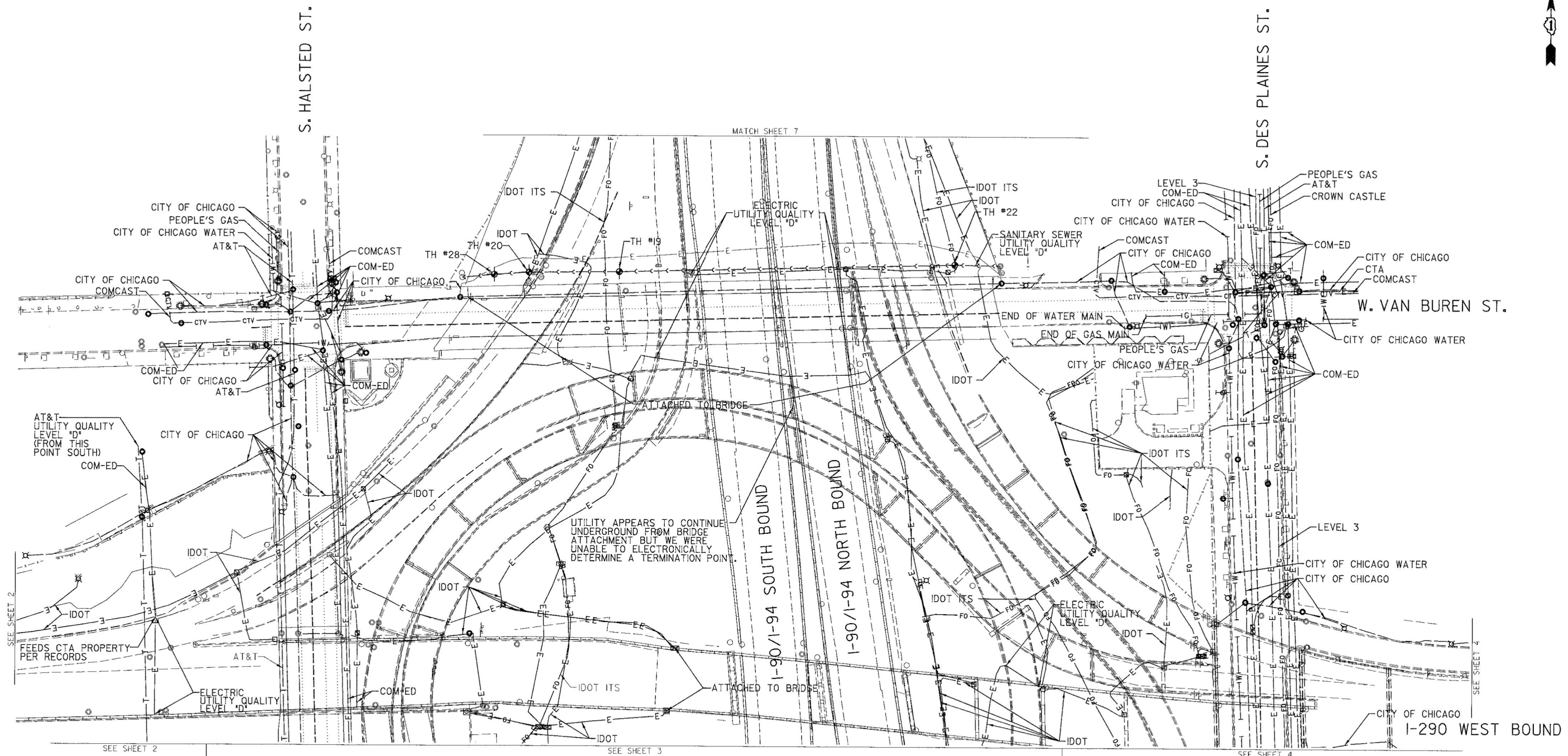
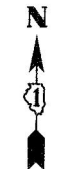

NOTE:
 THE CITY OF CHICAGO LINES (OTHER THAN THE WATER LINES), ARE MULTI-DUCT SYSTEMS, AND MAY CONTAIN ELECTRIC, TRAFFIC SIGNAL, CPS FIBER OPTICS, OEMC FIBER OPTICS, OTHER CITY COMMUNICATION LINES, AND OCCASIONALLY 3RD PARTY LINES. CARDNO HAS NOT ATTEMPTED TO DETERMINE THE NUMBER, SIZE, CONFIGURATION, OR OWNERSHIP OF THESE DUCT SYSTEMS. SUCH DETERMINATION SHOULD BE MADE BY OTHERS DURING THE UTILITY COORDINATION PROCESS.

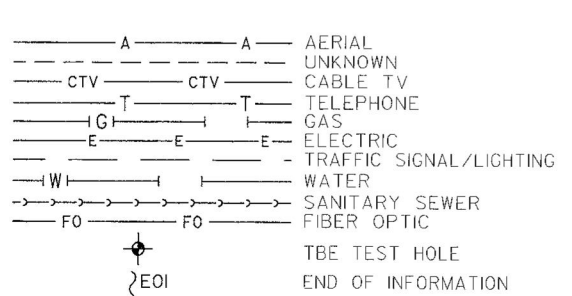

UTILITY OWNERS
 AT&T = TELEPHONE
 CITY OF CHICAGO = ELECTRIC
 CITY OF CHICAGO = FIBER OPTIC
 CITY OF CHICAGO WATER = WATER
 COMCAST = CABLE TV
 COM-ED = ELECTRIC
 CROWN CASTLE = FIBER OPTIC
 CTA = ELECTRIC
 IDOT = ELECTRIC
 IDOT ITS = FIBER OPTIC
 LEVEL 3 = FIBER OPTIC
 PEOPLE'S GAS = GAS

UTILITIES SHOWN ON THESE PLANS AS DEPICTED IN THE LEGEND HAVE BEEN INVESTIGATED BY CARDNO IN ACCORDANCE WITH SUE INDUSTRY STANDARDS. ALL OTHER INFORMATION SHOWN HAS BEEN PROVIDED TO CARDNO BY OTHERS. CARDNO SUE FIELD INVESTIGATION WAS PERFORMED 6/30/14 THROUGH 8/07/14. CHANGES TO UTILITIES MAY HAVE BEEN MADE AND THEREFORE MAY RESULT IN VARIANCES FROM THIS PLAN. CONSIDERATION SHOULD BE GIVEN TO UPDATING THIS PLAN IF DEEMED ADVISABLE PRIOR TO FINAL DESIGN AND CONSTRUCTION.

ALL UTILITIES SHOWN QUALITY LEVEL "B"
 UNLESS NOTED OTHERWISE.

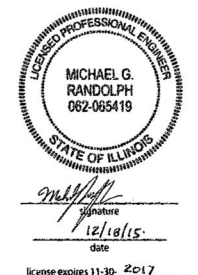

TBE Job No. IL09510531, 563, 647
 SUE Plan Page 3A of 12

Utility Quality Level 'A': Visually Verified Test Hole
 Utility Quality Level 'B': Designating/non Visually Verified Test Hole
 Utility Quality Level 'C': Research with Survey
 Utility Quality Level 'D': Records Research

DESIGNED	IP	REVISED
DRAWN	SRK	REVISED
CHECKED	MGR	REVISED
DATE	12/18/15	REVISED

STATE OF ILLINOIS
 DEPARTMENT OF TRANSPORTATION

I-94-901-290 (Circle Interchange)
 Chicago, Illinois

F.A. RTE.	SECTION	COUNTY	TOTAL SHEETS	SHEET NO.
	N/A	Cook	706	131
Contract No. N/A				
FED. ROAD DIST. NO. ILLINOIS IDOT Project No. P-91-259-12				

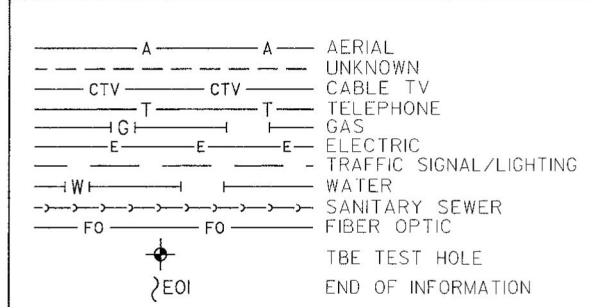
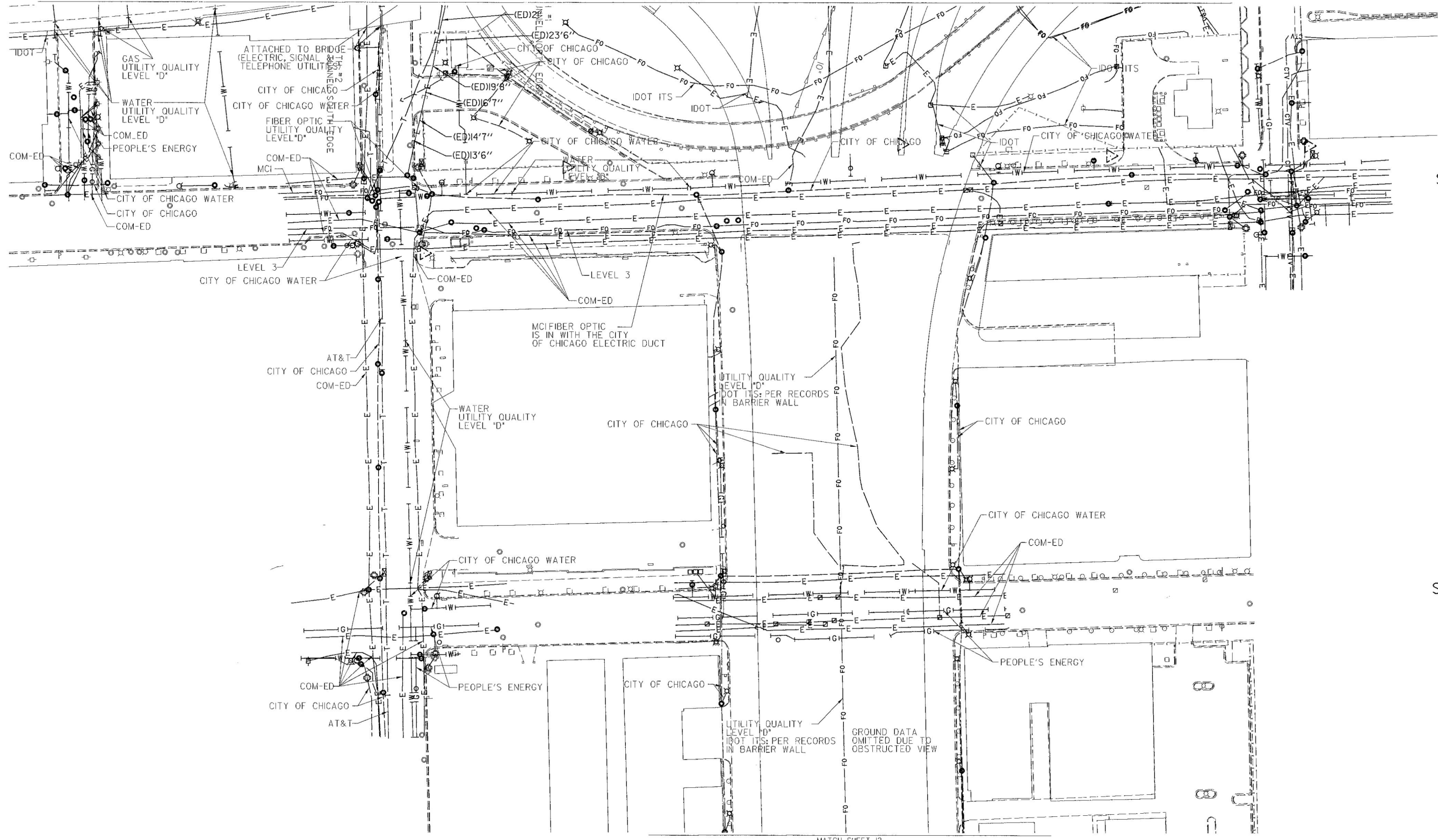
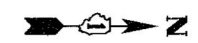

UTILITY OWNERS

AT&T = TELEPHONE
 COM-ED = ELECTRIC
 CITY OF CHICAGO = ELECTRIC
 CITY OF CHICAGO = SANITARY SEWER
 CITY OF CHICAGO WATER = WATER
 IDOT = ELECTRIC
 IDOT SURVEILLANCE = FIBER OPTIC
 LEVEL 3 = FIBER OPTIC
 MCI = FIBER OPTIC
 PEOPLE'S ENERGY = GAS

NOTE: ALL ELECTRONIC DEPTHS MARKED AS (ED) WERE OBTAINED UTILIZING A SONDE DEVICE. DEPTHS ON THE AT&T DUCT WERE RECORDED FROM AN AT&T CONTRACTOR. DEPTHS ON THE COMED DUCT WERE RECORDED BY A CARDNO CREW. CARDNO CAN NOT VERIFY THE ACCURACY OF THESE DEPTHS AND SHOULD BE USED AS APPROXIMATE AND AS INFORMATION ONLY.

UTILITIES SHOWN ON THESE PLANS AS DEPICTED IN THE LEGEND HAVE BEEN INVESTIGATED BY CARDNO IN ACCORDANCE WITH SUE INDUSTRY STANDARDS. ALL OTHER INFORMATION SHOWN HAS BEEN PROVIDED TO CARDNO BY OTHERS. CARDNO SUE FIELD INVESTIGATION WAS PERFORMED 3/14/13 THROUGH 8/07/14. CHANGES TO UTILITIES MAY HAVE BEEN MADE AND THEREFORE MAY RESULT IN VARIANCES FROM THIS PLAN. CONSIDERATION SHOULD BE GIVEN TO UPDATING THIS PLAN IF DEEMED ADVISABLE PRIOR TO FINAL DESIGN AND CONSTRUCTION.

ALL UTILITIES SHOWN QUALITY LEVEL "B" UNLESS NOTED OTHERWISE.

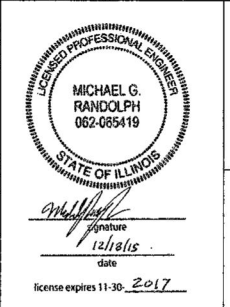

Engineers & Surveyors

TBE Job No. IL095053L 563, 647
 SUE Plan Page: 4 of 12

Utility Quality Level "A": Visually Verified Test Hole
 Utility Quality Level "B": Designating/non Visually Verified Test Hole
 Utility Quality Level "C": Research with Survey
 Utility Quality Level "D": Records Research

DESIGNED	JP	REVISED	
DRAWN	SRK	REVISED	
CHECKED	MGR	REVISED	
DATE	12/18/15	REVISED	

STATE OF ILLINOIS
 DEPARTMENT OF TRANSPORTATION

I-941-901-290 (Circle Interchange)
 Chicago, Illinois

F.A. RTE.	SECTION	COUNTY	TOTAL SHEETS	SHEET NO.
	N/A	Cook	706	132
Contract No. N/A				
FED. ROAD DIST. NO. ILLINOIS IDOT Project No. P-91-259-12				

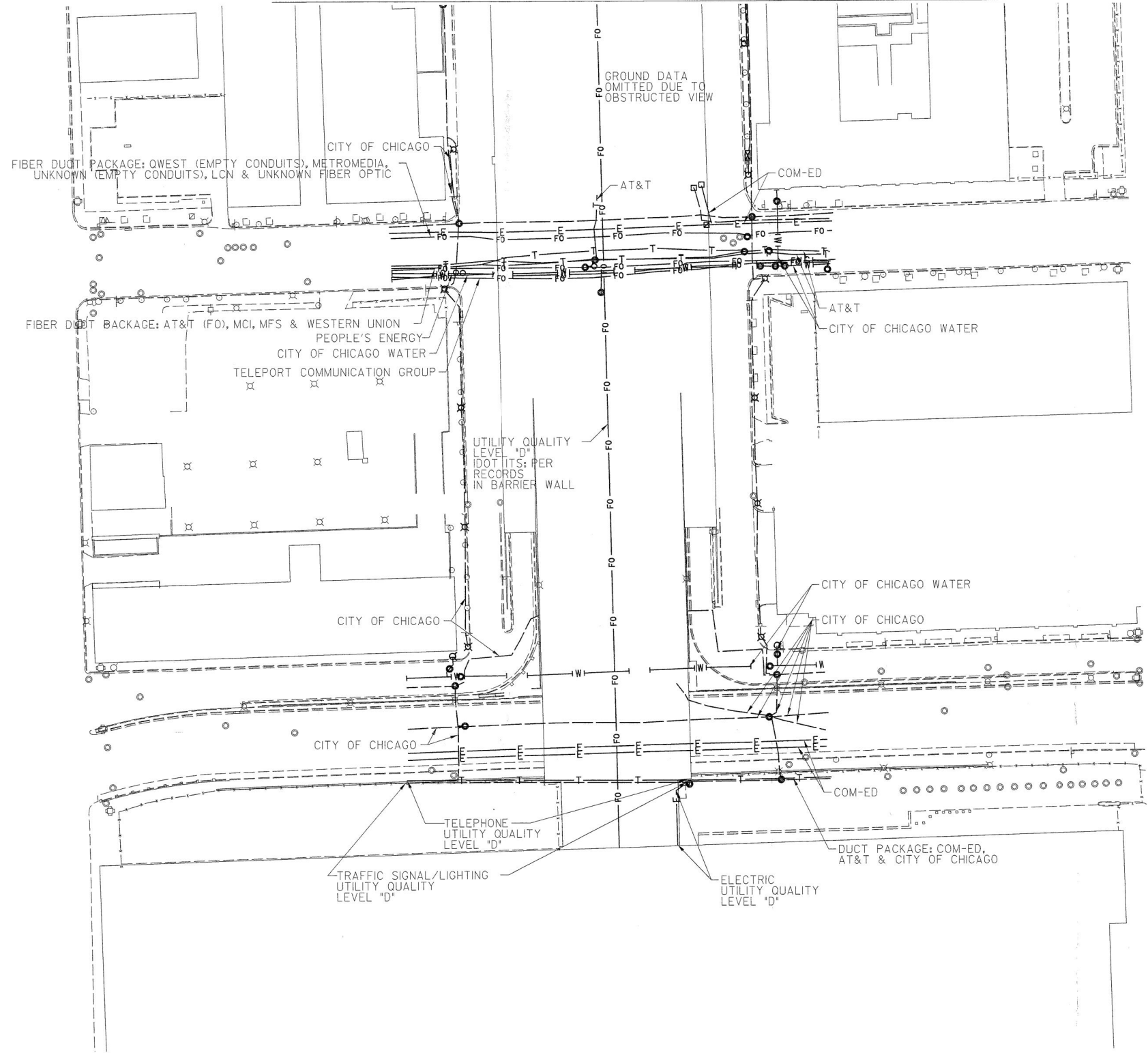
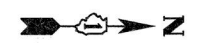

S. CLINTON ST.

S. CANAL ST.

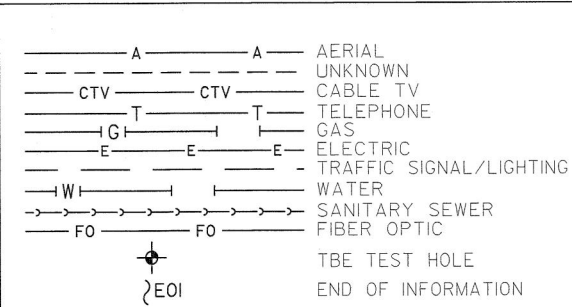

UTILITY OWNERS

AT&T = FIBER OPTIC
AT&T = TELEPHONE
COM-ED = ELECTRIC
CITY OF CHICAGO = ELECTRIC
CITY OF CHICAGO WATER = WATER
IDOT = ELECTRIC
LCN = FIBER OPTIC
MCI = FIBER OPTIC
METROMEDIA = FIBER OPTIC
MFS = FIBER OPTIC
PEOPLE'S ENERGY = GAS
TELEPORT COMM. GROUP = FIBER OPTIC
QWEST = FIBER OPTIC
WESTERN UNION = FIBER OPTIC

UTILITIES SHOWN ON THESE PLANS AS DEPICTED IN THE LEGEND HAVE BEEN INVESTIGATED BY CARDNO IN ACCORDANCE WITH SUE INDUSTRY STANDARDS. ALL OTHER INFORMATION SHOWN HAS BEEN PROVIDED TO CARDNO BY OTHERS. CARDNO SUE FIELD INVESTIGATION WAS PERFORMED 7/29/14 THROUGH 8/07/14. CHANGES TO UTILITIES MAY HAVE BEEN MADE AND THEREFORE MAY RESULT IN VARIANCES FROM THIS PLAN. CONSIDERATION SHOULD BE GIVEN TO UPDATING THIS PLAN IF DEEMED ADVISABLE PRIOR TO FINAL DESIGN AND CONSTRUCTION.

ALL UTILITIES SHOWN QUALITY LEVEL "B" UNLESS NOTED OTHERWISE.

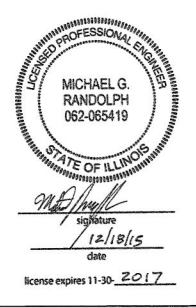

TBE Job No. IL0951053L 563, 647
SUE Plan Page: 12 of 12

Utility Quality Level 'A': Visually Verified Test Hole
Utility Quality Level 'B': Designating/non Visually Verified Test Hole
Utility Quality Level 'C': Research with Survey
Utility Quality Level 'D': Records Research

DESIGNED JP	REVISED
DRAWN SRK	REVISED
CHECKED MGR	REVISED
DATE 12/18/15	REVISED

STATE OF ILLINOIS
DEPARTMENT OF TRANSPORTATION

I-941-901-290 (Circle Interchange)
Chicago, Illinois

F.A. RTE.	SECTION	COUNTY	TOTAL SHEETS	SHEET NO.
	N/A	Cook	706	132A

Contract No. N/A	
FED. ROAD DIST. NO.	ILLINOIS IDOT Project No. P-91-259-12

FILE PATH = P:\6288727\000_CAD\006_Roadway\Printing\6288727_2016_03-18_F.mpl_Plot_Export\0160X78-SHT-Grading-01.dgn

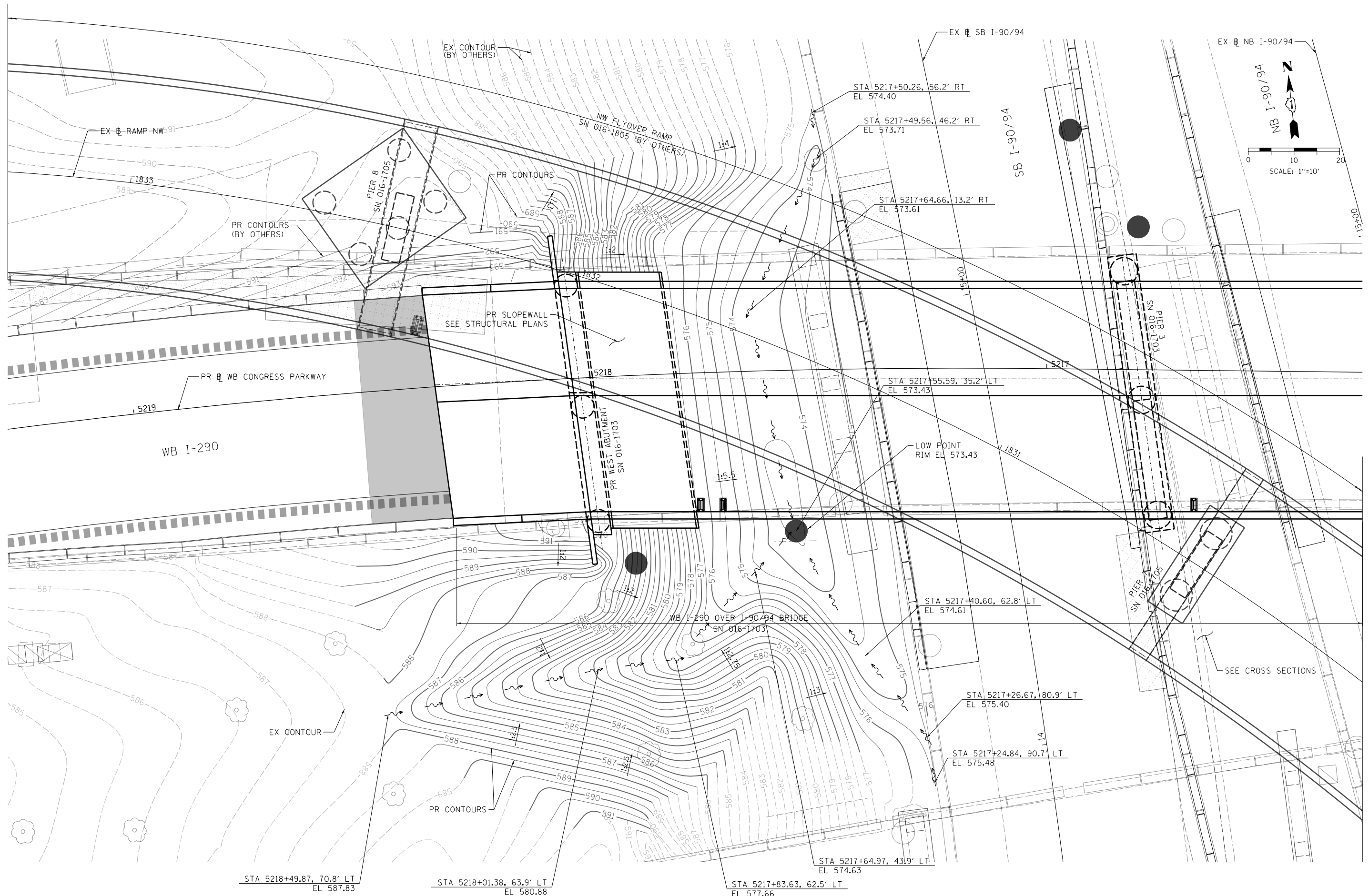

D160X78-SHT-Grading-01.dgn
 USER NAME = chiuw
 PLOT SCALE = 20.0000' / in.
 PLOT DATE = 3/20/2016

DESIGNED -	SDH/AFK	REVISED -	
DRAWN -	OPS	REVISED -	
CHECKED -	DBM	REVISED -	
DATE -	3/18/2016	REVISED -	

**STATE OF ILLINOIS
 DEPARTMENT OF TRANSPORTATION**

**PROPOSED GRADING PLAN
 AT WB I-290 OVER I-90/94 BRIDGE (WEST ABUTMENT)**
 SCALE: 1"=10' SHEET 1 OF 1 SHEETS STA. TO STA.

F.A.I. RTE.	SECTION	COUNTY	TOTAL SHEETS	SHEET NO.
90/94/290	2014-004R&B	COOK	706	133
CONTRACT NO. 60X78				
ILLINOIS FED. AID PROJECT				

PAVEMENT MARKING SCHEDULE

SHEET	ROADWAY/STATION	THERMOPLASTIC PAVEMENT MARKING - LETTERS AND SYMBOLS	THERMOPLASTIC PAVEMENT MARKING - LINE 4"	THERMOPLASTIC PAVEMENT MARKING - LINE 5"	THERMOPLASTIC PAVEMENT MARKING - LINE 6"	THERMOPLASTIC PAVEMENT MARKING - LINE 24"	EPOXY PAVEMENT MARKING - LINE 4"	EPOXY PAVEMENT MARKING - LINE 5"	EPOXY PAVEMENT MARKING - LINE 8"	EPOXY PAVEMENT MARKING - LINE 12"	PREFORMED PLASTIC PAVEMENT MARKING, TYPE B - LINE 5"	MODIFIED URETHANE PAVEMENT MARKING - LETTERS AND SYMBOLS	MODIFIED URETHANE PAVEMENT MARKING - LINE 4"	MODIFIED URETHANE PAVEMENT MARKING - LINE 5"	MODIFIED URETHANE PAVEMENT MARKING - LINE 8"	MODIFIED URETHANE PAVEMENT MARKING - LINE 12"
		SQ FT	FOOT	FOOT	FOOT	FOOT	FOOT	FOOT	FOOT	FOOT	FOOT	SQ FT	FOOT	FOOT	FOOT	FOOT
1	5218+33.89 TO 5206+00	-	-	-	-	-	3,299	827	53	117	605	-	2,957	-	2,522	366
2	5206+25 TO 382+00	-	-	-	-	-	-	-	-	-	282	89	2,021	457	2,553	52
3	382+00 TO DEARBORN (EX CL CONGRESS PARKWAY)	73	78	608	210	224	-	-	-	-	-	21	853	446	898	23
4	17+75 TO 24+66 (EX BL SB I-90/94)	-	-	-	-	-	1,878	2,525	151	66	-	-	-	-	-	-
	SUBTOTALS	73	78	608	210	224	5,177	3,352	204	183	887	110	5,831	903	5,973	441
	ALLOWANCE	11	12	92	32	34	777	503	31	28	133	17	875	136	896	67
	TOTALS WITH ALLOWANCE	84	90	700	242	258	5,954	3,855	235	211	1,020	127	6,706	1,039	6,869	508

SHEET	ROADWAY/STATION	RAISED REFLECTIVE PAVEMENT MARKER	RAISED REFLECTIVE PAVEMENT MARKER (BRIDGE)	REPLACEMENT REFLECTOR	PAVEMENT MARKING REMOVAL	RAISED REFLECTIVE PAVEMENT MARKER REMOVAL	GROOVING FOR RECESSED PAVEMENT MARKING 6"
		EACH	EACH	EACH	SQ FT	FOOT	FOOT
1	5218+33.89 TO 5206+00	83	61	83	4,882	83	605
2	5206+25 TO 382+00	-	75	-	2,825	-	282
3	382+00 TO DEARBORN (EX CL CONGRESS PARKWAY)	24	25	-	2,029	-	-
4	17+75 TO 24+66 (EX BL SB I-90/94)	51	-	51	1,845	51	-
	SUBTOTALS	158	161	134	11,581	134	887
	ALLOWANCE	24	25	21	1,738	21	133
	TOTALS WITH ALLOWANCE	182	186	155	13,319	155	1,020

FILE PATH = p:\61779-PMINT\ecomonline\local\AECOM\5902_NA\Documents\01_Americas\T\engp\station\60269938_Circle\Phase_11\000_CAD\006_Roadway\Sheets\60X78_Contract\0160X78-sht\PMK-Schedule-01.dgn



D160X78-sht-PMK-Schedule-01.dgn
 USER NAME = dshevoz
 PLOT SCALE = 100.0000' / 1" =
 PLOT DATE = 4/27/2016

DESIGNED - OPS
 DRAWN - OPS
 CHECKED - DBM
 DATE - 3/18/2016

REVISED -
 REVISED -
 REVISED -
 REVISED -

**STATE OF ILLINOIS
 DEPARTMENT OF TRANSPORTATION**

PAVEMENT MARKING SCHEDULE

SCALE: NONE SHEET 1 OF 1 SHEETS STA. TO STA.

F.A.I. RTE.	SECTION	COUNTY	TOTAL SHEETS	SHEET NO.
90/94/290	2014-004R&B	COOK	706	134
CONTRACT NO. 60X78			ILLINOIS FED. AID PROJECT	

MATCH LINE STA 17+75
(EX # SB I-90/94)
SEE SHEET NO. 138

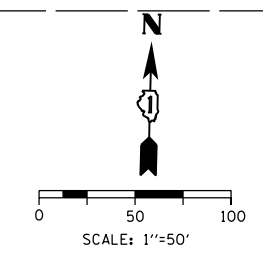

← ALL FINAL STRIPING SHALL BE COORDINATED WITH WB I-290 MAINLINE CONTRACT (BY OTHERS) SO THAT THERE ARE NO CONFLICTING PAVEMENT MARKINGS BETWEEN CONTRACTS. CONTRACTOR COORDINATION IS REQUIRED

- PAVEMENT MARKING NOTES**
1. ALL FINAL PAVEMENT MARKING MATERIALS PLACED ON PCC PAVEMENT SHALL BE MODIFIED URETHANE PAVEMENT MARKING AND PREFORMED PLASTIC PAVEMENT MARKING, TYPE B WITH GROOVING FOR RECESSED PAVEMENT MARKING EXCEPT WHERE NOTED IN THE PLANS.
 2. ALL FINAL PAVEMENT MARKING MATERIALS PLACED ON BITUMINOUS PAVEMENT SHALL BE THERMOPLASTIC EXCEPT WHERE NOTED IN THE PLANS.
 3. ALL FINAL PAVEMENT MARKING SYMBOLS SHALL BE OF SMALL SIZE.
 4. ALL DAMAGE TO EXISTING PAVEMENT MARKINGS OR RAISED REFLECTIVE PAVEMENT MARKERS OUTSIDE OF THE IMPROVEMENT LIMITS SHOWN ON THE PLANS SHALL BE REPLACED AT THE CONTRACTOR'S EXPENSE.
 5. BEFORE BEGINNING ANY WORK, THE CONTRACTOR SHALL RECORD AND RETAIN ALL EXISTING PAVEMENT MARKINGS AND MARKERS FOR FUTURE REFERENCE. EXACT LOCATIONS OF ALL PAVEMENT MARKINGS SHALL BE DIRECTED BY THE ENGINEER.
 6. THE RESIDENT ENGINEER SHALL CONTACT EXPRESSWAY TRAFFIC CONTROL SUPERVISOR AT 847-705-4155 AND ARTERIAL TRAFFIC CONTROL SUPERVISOR AT 847-705-4470 A MINIMUM OF 2 WEEKS PRIOR TO PLACEMENT OF PERMANENT PAVEMENT MARKINGS.
 7. PARTIAL STATIONS PROVIDED REFER TO PR # WB I-290 OR WB CONGRESS PARKWAY UNLESS OTHERWISE NOTED.

FILE PATH = p:\61779-PMINT\pccom\line\local\AECOM_D592_MIA\Documents\01_Americas\T\engpccom\station\60269938_Circle\Phase_11\000_CAD\006_Roadway\Sheets\6078-SHT-PMK-01.dgn
 CHICAGO, IL 60601-5276
 PHONE: (312) 373-1700 FAX: (312) 373-6800

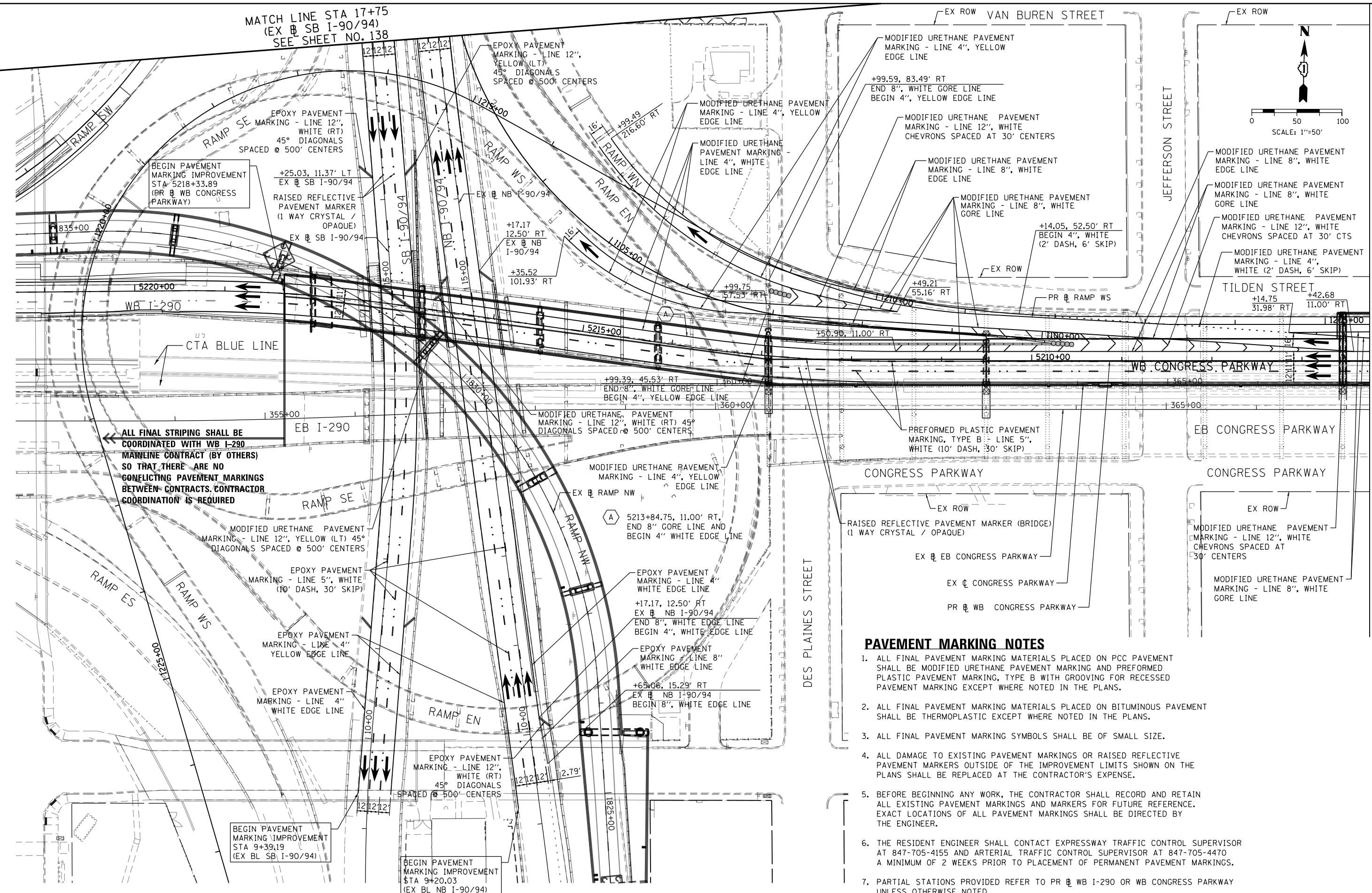

MATCH LINE STA 5206+25
(PR # WB CONGRESS PARKWAY)
SEE SHEET NO. 136



D16078-SHT-PMK-01.dgn
 USER NAME = dshevoz
 PLOT SCALE = 100.0000' / 1" =
 PLOT DATE = 4/27/2016

DESIGNED - OPS	REVISED -
DRAWN - OPS	REVISED -
CHECKED - DBM	REVISED -
DATE - 3/18/2016	REVISED -

STATE OF ILLINOIS
DEPARTMENT OF TRANSPORTATION

PAVEMENT MARKING PLAN
 WB I-290 OVER I-90/94 AND WB CONGRESS PARKWAY
 SCALE: 1"=50' SHEET 1 OF 4 SHEETS STA.5238+00 TO STA.5238+00

F.A.I. RTE. 90/94/290	SECTION 2014-004R&B	COUNTY COOK	TOTAL SHEETS 706	SHEET NO. 135
CONTRACT NO. 60X78				ILLINOIS FED. AID PROJECT

- A 5201+80.63, 52.99' RT, END 8" WHITE EDGE LINE
- B 5201+65.70, 37.15' RT (PC)
- C 5201+15.25, 87.48' RT (PT)
- D 5201+15.25, 147.80' RT, END 4" YELLOW EDGE LINE

- E 5202+07.48, END 9.63' LANES STRIPING AND BEGIN 45:1 TAPERS
- F 5204+37.53, 23.00' RT END OF LANE 4 RIGHT EDGE TAPER STRIPING
- G 5203+42.45, 11.00' RT END OF LANE 3 RIGHT EDGE TAPER STRIPING
- H 5202+97.36, 0' END OF LANE 2 RIGHT EDGE TAPER STRIPING
- I 5205+94.52, 23.73' RT

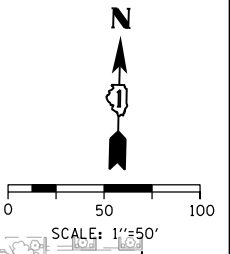

FILE PATH = p:\61779-PM\INT\pccom\line\loc\loc\DCM_D902_MIA\Documents\01_Americas\T\engp\station\60269938_Circle\Phase_1\1000_CAD\006_Roadway\Sheets\60x78_Contract\0160x78-SHT-PMK-02.dgn

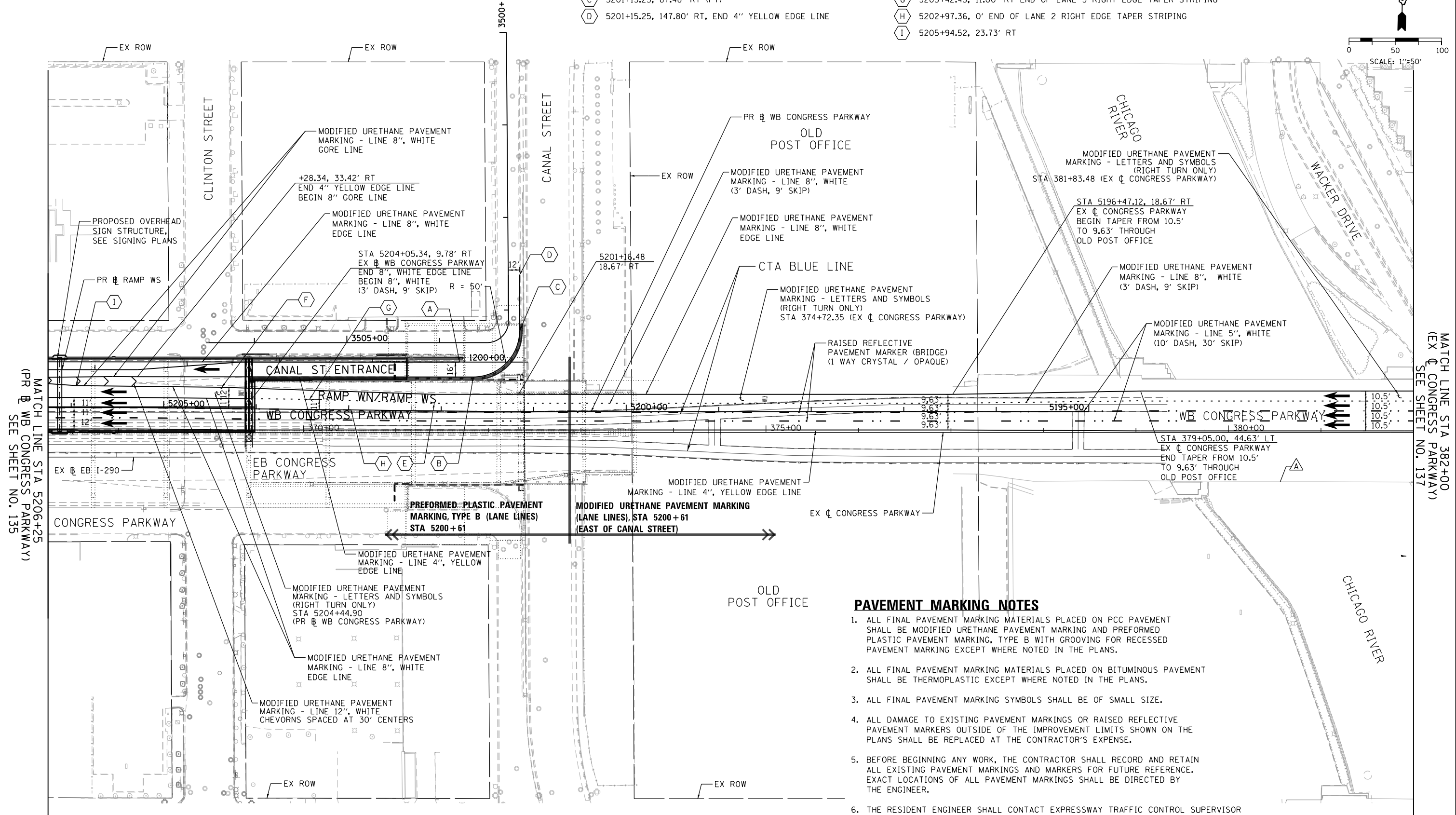

PAVEMENT MARKING NOTES

1. ALL FINAL PAVEMENT MARKING MATERIALS PLACED ON PCC PAVEMENT SHALL BE MODIFIED URETHANE PAVEMENT MARKING AND PREFORMED PLASTIC PAVEMENT MARKING, TYPE B WITH GROOVING FOR RECESSED PAVEMENT MARKING EXCEPT WHERE NOTED IN THE PLANS.
2. ALL FINAL PAVEMENT MARKING MATERIALS PLACED ON BITUMINOUS PAVEMENT SHALL BE THERMOPLASTIC EXCEPT WHERE NOTED IN THE PLANS.
3. ALL FINAL PAVEMENT MARKING SYMBOLS SHALL BE OF SMALL SIZE.
4. ALL DAMAGE TO EXISTING PAVEMENT MARKINGS OR RAISED REFLECTIVE PAVEMENT MARKERS OUTSIDE OF THE IMPROVEMENT LIMITS SHOWN ON THE PLANS SHALL BE REPLACED AT THE CONTRACTOR'S EXPENSE.
5. BEFORE BEGINNING ANY WORK, THE CONTRACTOR SHALL RECORD AND RETAIN ALL EXISTING PAVEMENT MARKINGS AND MARKERS FOR FUTURE REFERENCE. EXACT LOCATIONS OF ALL PAVEMENT MARKINGS SHALL BE DIRECTED BY THE ENGINEER.
6. THE RESIDENT ENGINEER SHALL CONTACT EXPRESSWAY TRAFFIC CONTROL SUPERVISOR AT 847-705-4155 AND ARTERIAL TRAFFIC CONTROL SUPERVISOR AT 847-705-4470 A MINIMUM OF 2 WEEKS PRIOR TO PLACEMENT OF PERMANENT PAVEMENT MARKINGS.
7. PARTIAL STATIONS PROVIDED REFER TO PR WB I-290 OR WB CONGRESS PARKWAY UNLESS OTHERWISE NOTED.

MATCH LINE STA 5206+25
 (PR WB CONGRESS PARKWAY)
 SEE SHEET NO. 135

MATCH LINE STA 382+00
 (EX CONGRESS PARKWAY)
 SEE SHEET NO. 137



D160X78-SHT-PMK-02.dgn	DESIGNED - OPS	REVISED -
USER NAME = dshevoz	DRAWN - OPS	REVISED -
PLOT SCALE = 100.0000' / 1"	CHECKED - DBM	REVISED -
PLOT DATE = 4/27/2016	DATE - 3/18/2016	REVISED -

**STATE OF ILLINOIS
 DEPARTMENT OF TRANSPORTATION**

PAVEMENT MARKING PLAN	
WB I-290 OVER I-90/94 AND WB CONGRESS PARKWAY	
SCALE: 1"=50'	SHEET 2 OF 4 SHEETS
STA.5238+00	TO STA.5238+00

F.A.I. RTE.	SECTION	COUNTY	TOTAL SHEETS	SHEET NO.
90/94/290	2014-004R&B	COOK	706	136
CONTRACT NO. 60X78				
ILLINOIS FED. AID PROJECT				

FILE PATH = p:\61779-PMINT\pawcom\line\local\AECOM_D902_NA\Documents\01_Americas\T\engp\station\60269438_Circle\Phase_11\000_CAD\006_Roadway\Sheets\60x78_Contract\0160x78-SHT-PMK-03.dgn

MATCH LINE STA 382+00
(EX EB CONGRESS PARKWAY)
SEE SHEET NO. 136

MATCH LINE "A"
SEE BELOW

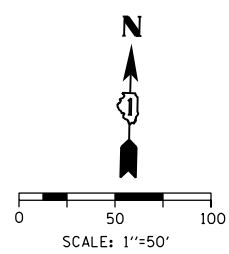
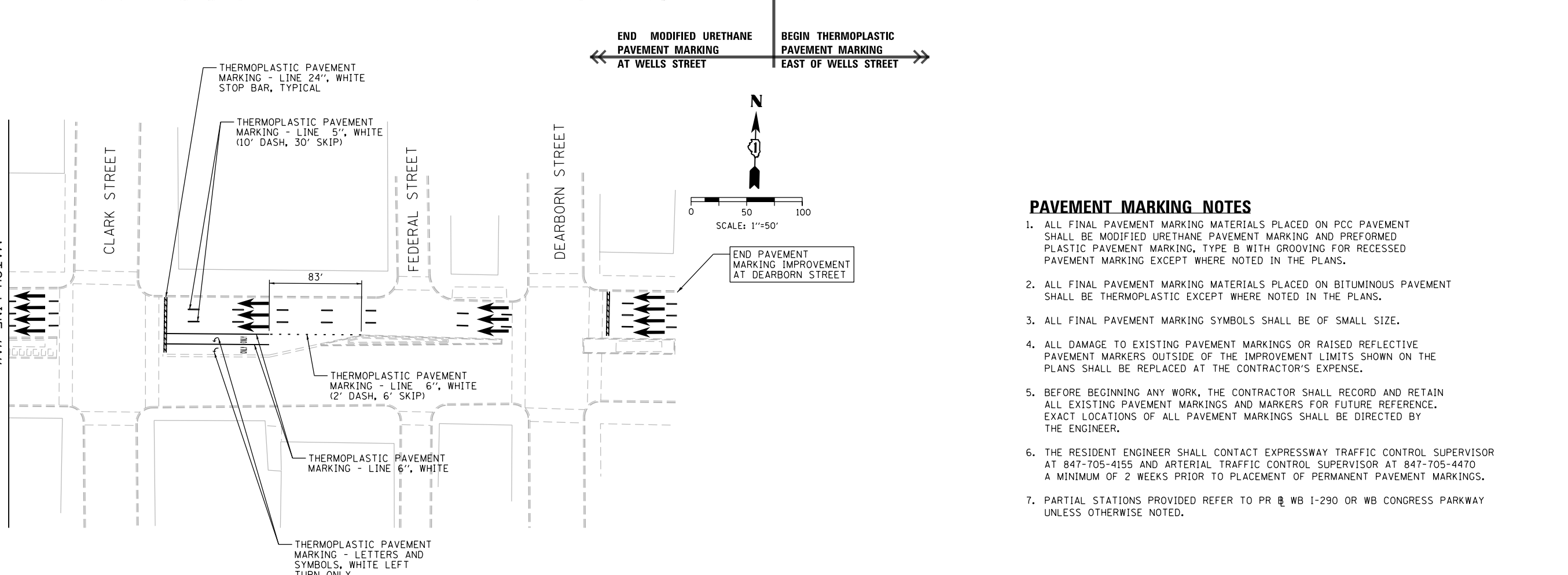
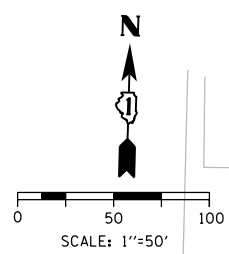
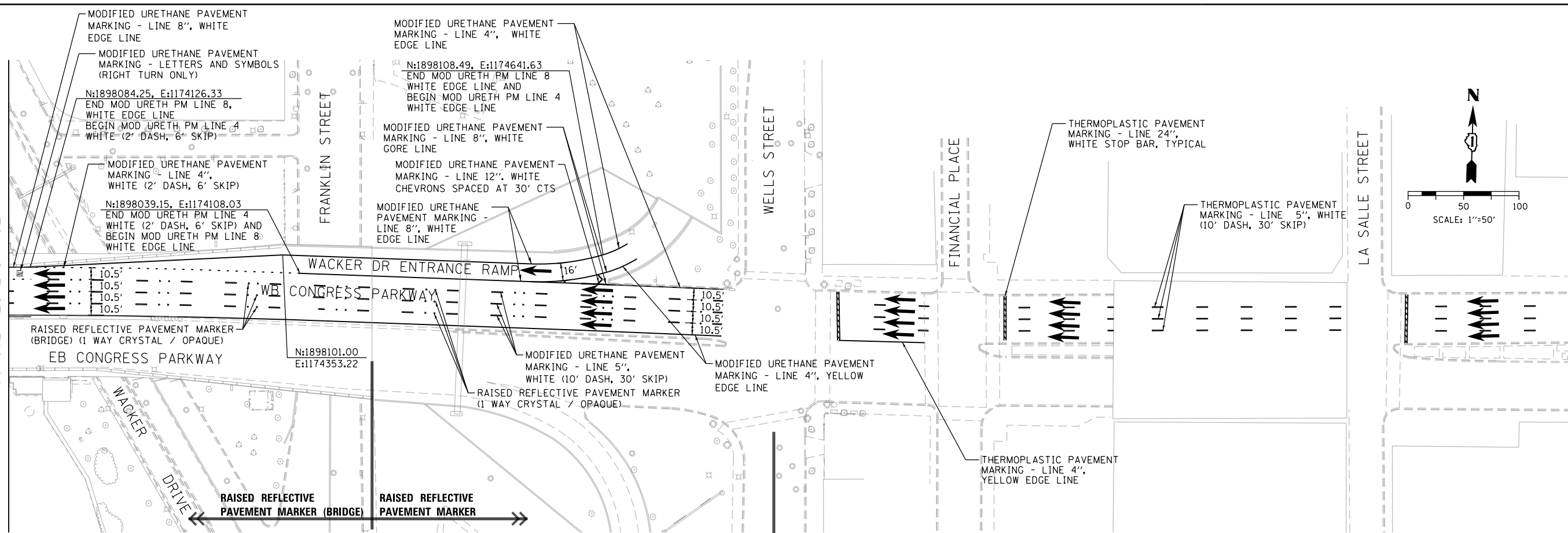

PAVEMENT MARKING NOTES

1. ALL FINAL PAVEMENT MARKING MATERIALS PLACED ON PCC PAVEMENT SHALL BE MODIFIED URETHANE PAVEMENT MARKING AND PREFORMED PLASTIC PAVEMENT MARKING, TYPE B WITH GROOVING FOR RECESSED PAVEMENT MARKING EXCEPT WHERE NOTED IN THE PLANS.
2. ALL FINAL PAVEMENT MARKING MATERIALS PLACED ON BITUMINOUS PAVEMENT SHALL BE THERMOPLASTIC EXCEPT WHERE NOTED IN THE PLANS.
3. ALL FINAL PAVEMENT MARKING SYMBOLS SHALL BE OF SMALL SIZE.
4. ALL DAMAGE TO EXISTING PAVEMENT MARKINGS OR RAISED REFLECTIVE PAVEMENT MARKERS OUTSIDE OF THE IMPROVEMENT LIMITS SHOWN ON THE PLANS SHALL BE REPLACED AT THE CONTRACTOR'S EXPENSE.
5. BEFORE BEGINNING ANY WORK, THE CONTRACTOR SHALL RECORD AND RETAIN ALL EXISTING PAVEMENT MARKINGS AND MARKERS FOR FUTURE REFERENCE. EXACT LOCATIONS OF ALL PAVEMENT MARKINGS SHALL BE DIRECTED BY THE ENGINEER.
6. THE RESIDENT ENGINEER SHALL CONTACT EXPRESSWAY TRAFFIC CONTROL SUPERVISOR AT 847-705-4155 AND ARTERIAL TRAFFIC CONTROL SUPERVISOR AT 847-705-4470 A MINIMUM OF 2 WEEKS PRIOR TO PLACEMENT OF PERMANENT PAVEMENT MARKINGS.
7. PARTIAL STATIONS PROVIDED REFER TO PR WB I-290 OR WB CONGRESS PARKWAY UNLESS OTHERWISE NOTED.



D160x78-SHT-PMK-03.dgn	DESIGNED - OPS	REVISED -
USER NAME = dshevoz	DRAWN - OPS	REVISED -
PLOT SCALE = 100.0000' / 1"	CHECKED - DBM	REVISED -
PLOT DATE = 4/27/2016	DATE - 3/18/2016	REVISED -

**STATE OF ILLINOIS
DEPARTMENT OF TRANSPORTATION**

PAVEMENT MARKING PLAN	
WB I-290 OVER I-90/94 AND WB CONGRESS PARKWAY	
SCALE: 1"=50'	SHEET 3 OF 4 SHEETS
STA.5238+00	TO STA.5238+00

F.A.I. RTE.	SECTION	COUNTY	TOTAL SHEETS	SHEET NO.
90/94/290	2014-004R&B	COOK	706	137
CONTRACT NO. 60X78				
ILLINOIS FED. AID PROJECT				

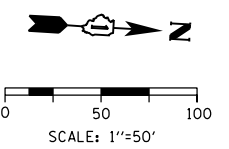

(A) STA 20+15.16, 23.22' LT (EX @ NB I-90/94)
 (B) STA 21+24.73, 3.37' LT (EX @ SB I-90/94)

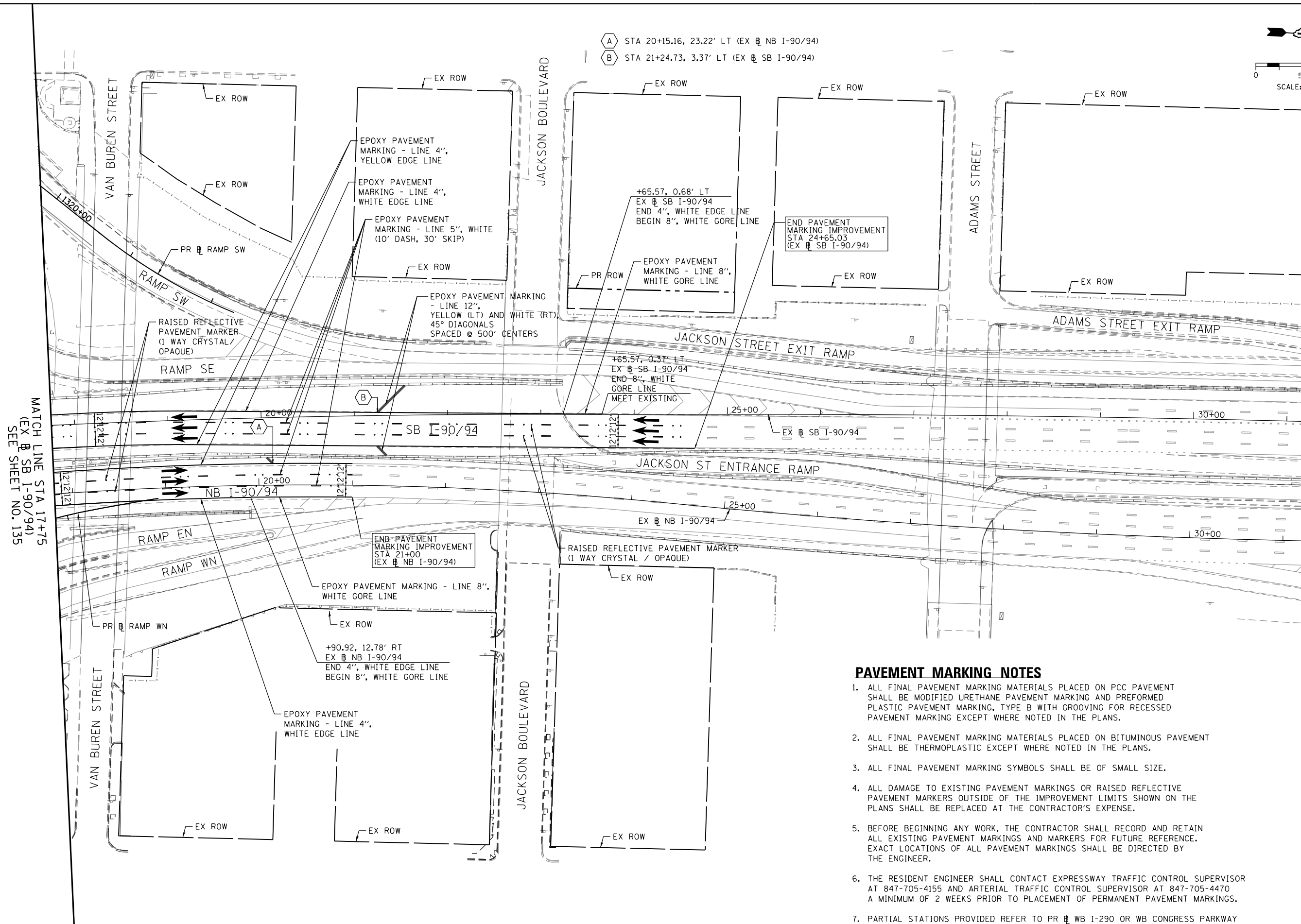

MATCH LINE STA 17+75
 (EX @ SB I-90/94)
 SEE SHEET NO. 135

PAVEMENT MARKING NOTES

1. ALL FINAL PAVEMENT MARKING MATERIALS PLACED ON PCC PAVEMENT SHALL BE MODIFIED URETHANE PAVEMENT MARKING AND PREFORMED PLASTIC PAVEMENT MARKING, TYPE B WITH GROOVING FOR RECESSED PAVEMENT MARKING EXCEPT WHERE NOTED IN THE PLANS.
2. ALL FINAL PAVEMENT MARKING MATERIALS PLACED ON BITUMINOUS PAVEMENT SHALL BE THERMOPLASTIC EXCEPT WHERE NOTED IN THE PLANS.
3. ALL FINAL PAVEMENT MARKING SYMBOLS SHALL BE OF SMALL SIZE.
4. ALL DAMAGE TO EXISTING PAVEMENT MARKINGS OR RAISED REFLECTIVE PAVEMENT MARKERS OUTSIDE OF THE IMPROVEMENT LIMITS SHOWN ON THE PLANS SHALL BE REPLACED AT THE CONTRACTOR'S EXPENSE.
5. BEFORE BEGINNING ANY WORK, THE CONTRACTOR SHALL RECORD AND RETAIN ALL EXISTING PAVEMENT MARKINGS AND MARKERS FOR FUTURE REFERENCE. EXACT LOCATIONS OF ALL PAVEMENT MARKINGS SHALL BE DIRECTED BY THE ENGINEER.
6. THE RESIDENT ENGINEER SHALL CONTACT EXPRESSWAY TRAFFIC CONTROL SUPERVISOR AT 847-705-4155 AND ARTERIAL TRAFFIC CONTROL SUPERVISOR AT 847-705-4470 A MINIMUM OF 2 WEEKS PRIOR TO PLACEMENT OF PERMANENT PAVEMENT MARKINGS.
7. PARTIAL STATIONS PROVIDED REFER TO PR @ WB I-290 OR WB CONGRESS PARKWAY UNLESS OTHERWISE NOTED.

FILE PATH = p:\6179-PMINT\pccom\line\loc\p\AECOM_D902_NA\Documents\01_Americas\T\engor\station\60269938_Circle\Phase_11\000_CAD\006_Roadway\Sheets\60X78_Contract\0160X78-SHT-PMK-04.dgn



D160X78-SHT-PMK-04.dgn	DESIGNED - OPS	REVISED -
USER NAME = dshevoz	DRAWN - OPS	REVISED -
PLOT SCALE = 100.0000' / in.	CHECKED - DBM	REVISED -
PLOT DATE = 4/27/2016	DATE - 3/18/2016	REVISED -

**STATE OF ILLINOIS
 DEPARTMENT OF TRANSPORTATION**

PAVEMENT MARKING PLAN	
WB I-290 OVER I-90/94 AND WB CONGRESS PARKWAY	
SCALE: 1"=50'	SHEET 4 OF 4 SHEETS
STA.5238+00	TO STA.5238+00

F.A.I. RTE.	SECTION	COUNTY	TOTAL SHEETS	SHEET NO.
90/94/290	2014-004R&B	COOK	706	138
CONTRACT NO. 60X78				
ILLINOIS FED. AID PROJECT				

SIGNING REMOVAL AND PROPOSED SIGNING SCHEDULE

DESCRIPTION				LOCATION (STATION / OFFSET)		EXISTING PANEL DIMENSIONS		SIGN PANEL - TYPE 1	SIGN PANEL - TYPE 2	SIGN PANEL - TYPE 3	REMOVE SIGN PANEL ASSEMBLY - TYPE A	REMOVE SIGN PANEL ASSEMBLY - TYPE B	REMOVE SIGN PANEL - TYPE 1	REMOVE SIGN PANEL - TYPE 2	RELOCATE SIGN PANEL - TYPE 1	METAL POST - TYPE A	BASE FOR SIGN SUPPORT, SPECIAL	REMOVE SIGN PANEL - TYPE 3	OVERHEAD SIGN STRUCTURE - SPAN, TYPE III-A (5' - 0" X 7' - 0")	REMOVE OVERHEAD SIGN STRUCTURE - SPAN	SIGN PANEL OVERLAY			
LOCATION	SIGN NO.	LEGEND / DESCRIPTION	SIGN TYPE			WIDTH (FT)	HEIGHT (FT)	(SQ FT)	(SQ FT)	(SQ FT)	(EACH)	(EACH)	(SQ FT)	(SQ FT)	(SQ FT)	(FOOT)	(EACH)	(SQ FT)	(FOOT)	(EACH)	(SQ FT)			
WB I-290	EX-01A	SPEED LIMIT 35	R2-1	5208+97.43	OVERHEAD SIGN STRUCTURE	4.00	5.00																	
	EX-01B *	I-290 WB EISENHOWER EXPWY, WEST SUBURBS, DOWN ARROWS	GUIDE			27.00	10.50													284				
	EX-01C *	LANE ENDS, MERGE LEFT	GUIDE			6.50	4.00														26			
	EX-01D *	I-90/94 WB KENNEDY EXPWY, WISCONSIN	GUIDE			28.00	11.50														322			
		I-90/94 EB RYAN EXPWY, INDIANA	GUIDE																					
	EX-01E	RAMP 35 M. P. H.	W13-3			4.00	5.00																	
	WB-01A	SPEED LIMIT 35	R2-1	5206+12.43	PR OVERHEAD SIGN STRUCTURE (SEE OH SIGN STRUCTURAL PLANS)				20															
	WB-01B	I-290 WB EISENHOWER EXPWY, WEST SUBURBS, DOWN ARROWS	GUIDE			28.50	10.50					300												
	WB-01C	I-90/94 DAN RYAN KENNEDY EXPWY, INDIANA WISCONSIN, EXIT ONLY WITH ARROW	GUIDE			20.00	15.00						300									82		
WB-01D	RAMP 35 M. P. H.	W13-3	4.00			5.00				20														
WB-01E	ACCESS TO I-290 PROHIBITED	GUIDE	9.00	8.00					72											SEE NOTE 2				
TILDEN STREET	TL-04A	DO NOT ENTER	R5-1	5204+12.79	56' RT	2.50	2.50																	
	TL-04B	ONE WAY (LT)	R6-2L			1.50	2.00											18.0	1					
	TL-04C	NO RIGHT TURN	R3-2			2.00	2.00																	
	TL-05A	NO PARKING, TOW ZONE (LT)	R7	5203+77.70	56.5' RT	1.50	1.50																	
	TL-05B	NO PARKING, TOW ZONE (RT)	R7			1.50	1.50											14.5	1					
	TL-06A	NO PARKING, TOW ZONE, ANYTIME EXCEPT VEHICLES DISPLAYING, PERMIT 738 (LT)	R7	5203+63.92	56.5' RT	1.50	1.50																	
	TL-06B	NO PARKING, TOW ZONE (RT)	R7			1.50	1.50											14.5	1					
TL-07	NO PARKING, TOW ZONE, ANYTIME EXCEPT VEHICLES DISPLAYING, PERMIT 738	R7	5202+86.67	57.9' RT	1.50	1.50										13.0	1							
WB I-290	WB-02	MERGE RIGHT	W4-1R	5203+40.85	31.4' RT	4.00	4.00																	
	WB-03	USE PROHIBITED BY MOTOR DRIVEN CYCLES, FARM IMPLEMENTS, PEDESTRIANS, NON-MOTORIZED TRAFFIC, BUCKLE UP	R5-1100	5201+96.51	32.9' RT	4.00	5.00			16														
	EX-02A	DO NOT ENTER	R5-1	5204+12.79	56' RT	2.50	2.50																	
	EX-02B	ONE WAY (LT)	R6-2L			1.50	2.00																	
	EX-02C	NO RIGHT TURN	R3-2			2.00	2.00																	
	EX-03A	NO PARKING, TOW ZONE (LT)	R7	5203+77.70	56.5' RT	1.50	1.50																	
	EX-03B	NO PARKING, TOW ZONE (RT)	R7			1.50	1.50																	
	EX-04A	NO PARKING, TOW ZONE, ANYTIME EXCEPT VEHICLES DISPLAYING, PERMIT 738 (LT)	R7	5203+63.92	56.5' RT	1.50	1.50																	
	EX-04B	NO PARKING, TOW ZONE (RT)	R7			1.50	1.50																	
	EX-05	MERGE RIGHT	W4-1R	5203+40.85	31.4' RT	4.00	4.00							16										
EX-06	NO PARKING, TOW ZONE, ANYTIME EXCEPT VEHICLES DISPLAYING, PERMIT 738	R7	5202+86.67	57.9' RT	1.50	1.50																		
EX-07	USE PROHIBITED BY MOTOR DRIVEN CYCLES, FARM IMPLEMENTS, PEDESTRIANS, NON-MOTORIZED TRAFFIC, BUCKLE UP	R5-1100	5201+96.51	32.9' RT	4.00	5.00								20										
EX-08	UNKNOWN	UNK	5201+23.05	40' RT	1.50	2.00																		
EX-09	CHICAGO EXPRESSWAY, KEEP THEM CLEAN (ON NORTH FACE OF EXISTING PIER)	INFO	5217+52.35	25.7' RT	2.00	3.00																		
CANAL STREET	CN-01	I-90 SHIELD	M1-1	-	-	2.00	2.00																	
		I-94 SHIELD	M1-1			2.00	2.00																	
		DIRECTIONAL ARROW	M6-1			1.75	1.25																	
	CN-02	I-90 SHIELD	M1-1			2.00	2.00																	
		I-94 SHIELD	M1-1			2.00	2.00																	
		DIRECTIONAL ARROW	M6-1			1.75	1.25																	
CN-03	I-90 SHIELD	M1-1	5201+51.17	89.3' RT	2.00	2.00																		
	I-94 SHIELD	M1-1			2.00	2.00																		
	DIRECTIONAL ARROW	M6-2			1.75	1.25																		
VAN BUREN STREET	EX-10-SP	TO HARRISON, TO I-290	CUSTOM			4.00	3.50																	
	VN-01	TO HARRISON, TO I-290	CUSTOM			4.00	3.50			14														
	VN-02	I-90 SHIELD	M1-1			3.00	3.00																	
		I-94 SHIELD	M1-1			3.00	3.00																	
EX-11-SP	I-290 SHIELD	M1-2			2.50	2.00						5												
WB I-290	-	"EXIT ONLY WITH DOWN ARROW" OVERLAY ON EXISTING OVERHEAD SIGN PANEL ON WB CONGRESS PARKWAY BETWEEN FRANKLIN ST AND WELLS ST SIGNING FOR I-90/94 DAN RYAN/KENNEDY TO INDIANA / WISCONSIN	-			20.00	3.00														60			
ROUNDED TOTAL								80	90	672	2	3	5	50	6	60	4	632	82	1	60			

NOTE: 1. THE DIMENSIONS OF THE EXISTING SIGN PANELS SHOWN WITH AN ASTERISK (*) ARE APPROXIMATED FOR QUANTITY PURPOSES. THE CONTRACTOR SHALL FIELD VERIFY THE EXACT SIGN PANEL DIMENSIONS. FIELD ADJUSTMENT MAY BE REQUIRED.

2. QUANTITY SHOWN FOR INFORMATION ONLY. SEE OVERHEAD SIGN STRUCTURES PLANS FOR DETAILS.



D:\6078-sht-Sign-Schedule-01.dgn
 USER NAME = dshevoz
 PLOT SCALE = 100.0000' / in.
 PLOT DATE = 4/27/2016

DESIGNED - OPS
 DRAWN - OPS
 CHECKED - DBM
 DATE - 3/18/2016

STATE OF ILLINOIS
 DEPARTMENT OF TRANSPORTATION

SIGNING SCHEDULE

SCALE: NONE SHEET 1 OF 1 SHEETS STA. TO STA.

F.A.I. RTE.	SECTION	COUNTY	TOTAL SHEETS	SHEET NO.
90/94/290	2014-004R&B	COOK	706	139
CONTRACT NO. 60X78				
ILLINOIS FED. AID PROJECT				

FILE PATH = p:\6179-P\MINT\rescom\line\local\AECOM_D592_NA\Documents\01_Americas\T_engor\station\602695938_Circle\Phase_1\1000_CAD\006_Roadway\Sheets\60X78_Contract\016978-sht-Sign-Schedule-01.dgn

SIGNING NOTES

- SEE SIGN SCHEDULE FOR SIGN PANEL AND MOUNTING INFORMATION.
- BEFORE BEGINNING ANY WORK, THE CONTRACTOR SHALL RECORD AND RETAIN ALL EXISTING SIGN INFORMATION FOR FUTURE REFERENCE. EXACT LOCATIONS OF ALL SIGNS SHALL BE DIRECTED BY THE ENGINEER. IT SHALL BE THE CONTRACTOR'S RESPONSIBILITY TO VERIFY ALL DIMENSIONS AND CONDITIONS IN THE FIELD PRIOR TO CONSTRUCTION AND ORDERING OF MATERIALS.
- THE CONTRACTOR SHALL CONTACT THE DISTRICT OF ARTERIAL TRAFFIC CONTROL SUPERVISOR AT (847) 705-4470 AND THE EXPRESSWAYS TRAFFIC CONTROL SUPERVISOR AT (847) 705-4155 A MINIMUM OF 72 HOURS IN ADVANCE OF BEGINNING WORK ON OVERHEAD SIGNS AND OVERHEAD SIGN STRUCTURES.

(A) EXISTING SIGN PANEL TO REMAIN ON EXISTING OVERHEAD SIGN STRUCTURE



EX-01A-0V
R2-1
(48"x60")
FACING
EB I-290

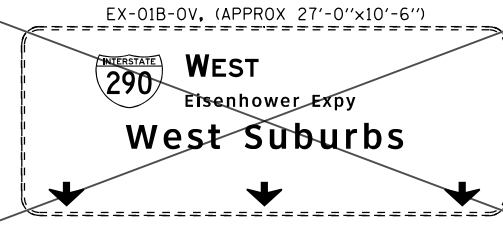

EX-01B-0V, (APPROX 27'-0" x 10'-6")



EX-01C-0V
(APPROX 6'-6" x 3'-0")

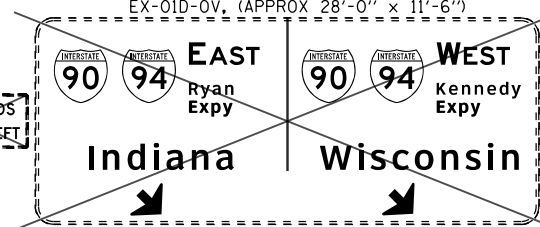

EX-01D-0V, (APPROX 28'-0" x 11'-6")

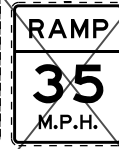

EX-01E-0V
W13-3
(48"x60")

(D) STA 5208+97.43
REMOVE OVERHEAD SIGN STRUCTURE - SPAN

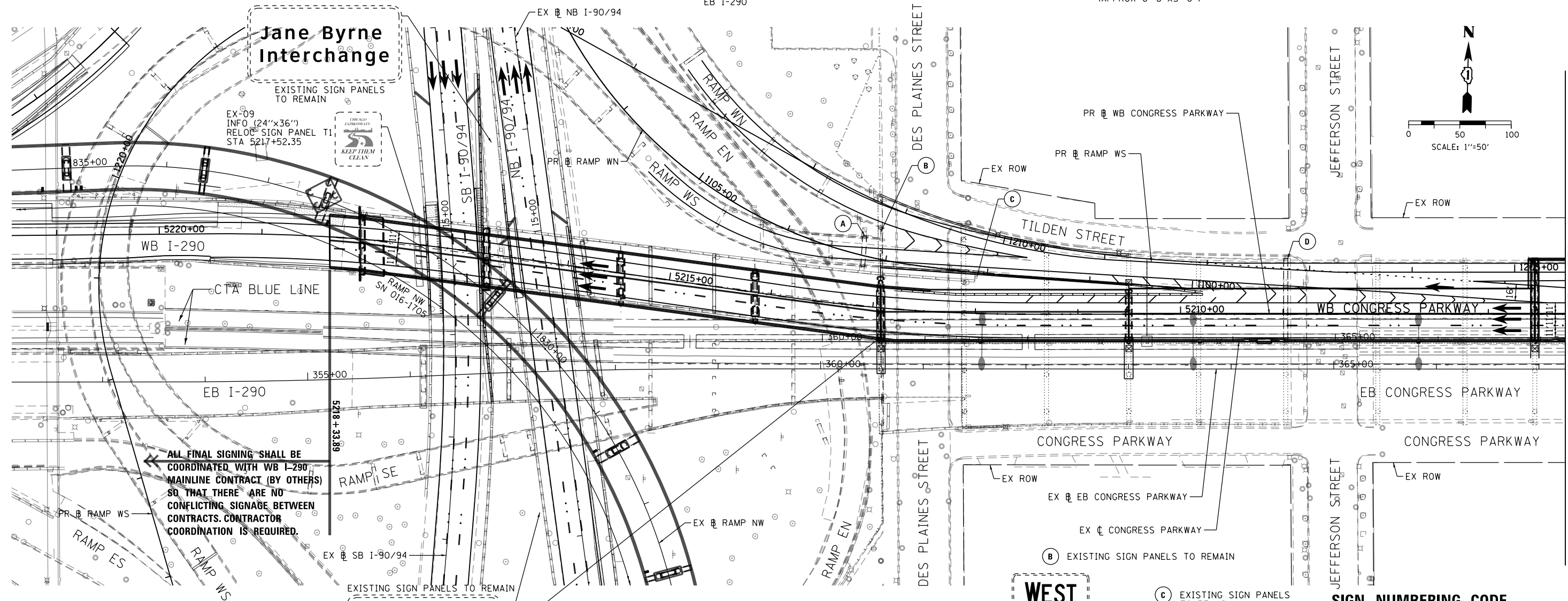

Jane Byrne Interchange

EXISTING SIGN PANELS TO REMAIN

EX-09
INFO (24"x36")
RELOC SIGN PANEL T1
STA 5217+52.35



ALL FINAL SIGNING SHALL BE COORDINATED WITH WB I-290 MAINLINE CONTRACT (BY OTHERS) SO THAT THERE ARE NO CONFLICTING SIGNAGE BETWEEN CONTRACTS. CONTRACTOR COORDINATION IS REQUIRED.

Jane Byrne Interchange

EXISTING SIGN PANELS TO REMAIN



(B) EXISTING SIGN PANELS TO REMAIN

(C) EXISTING SIGN PANELS TO REMAIN

SIGN NUMBERING CODE EXAMPLE

DIRECTION OF TRAFFIC	EXAMPLE	MOUNTING TYPE
TL - TILDEN STREET	NB-03-LP	ST - STEEL POST
CN - CANAL STREET		TS - TELESCOPING STEEL
VN - VAN BUREN STREET		MP - METAL POST
WB - WESTBOUND I-290		LP - LIGHT POLE BANDING
EX - EXISTING		SP - SIGNAL POLE BANDING
SIGN PANEL NUMBER		SA - SIGNAL POLE MAST ARM
		BM - BRIDGE MOUNTED
		PM - PARAPET MOUNTED
		PP - PEDESTRIAN PUSH BUTTON
		BS - BREAKAWAY STEEL
		WP - WOOD POST
		OV - OVERHEAD
		TM - SIGN TRUSS MOUNTED
		(S) - SPECIAL

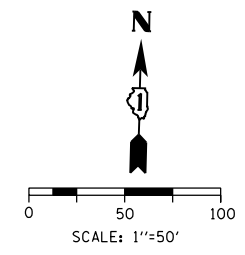

MATCH LINE STA 5206+25
(PR WB CONGRESS PARKWAY)
SEE SHEET NO. 141

FILE PATH = p:\617479-PMINT\pccom\line\local\AECOM_D902_NA\Documents\01_Americas\T\engor\station\602694938_Circle\Phase_11\000_CAD\006_Roadway\Sheets\60x78_Contract\016978-SHT-Sign-01.dgn



D160X78-SHT-Sign-01.dgn
USER NAME = dshevoz
PLOT SCALE = 100.0000' / 1" =
PLOT DATE = 4/27/2016

DESIGNED - OPS	REVISED -
DRAWN - OPS	REVISED -
CHECKED - DBM	REVISED -
DATE - 3/18/2016	REVISED -

STATE OF ILLINOIS
DEPARTMENT OF TRANSPORTATION

SIGNING PLAN
WB I-290 OVER I-90/94 AND WB CONGRESS PARKWAY

SCALE: 1"=50' SHEET 1 OF 3 SHEETS STA. 5218+33.89 TO STA. 5206+25

F.A.I. RTE.	SECTION	COUNTY	TOTAL SHEETS	SHEET NO.
90/94/290	2014-004R&B	COOK	706	140
CONTRACT NO. 60X78				
ILLINOIS FED. AID PROJECT				

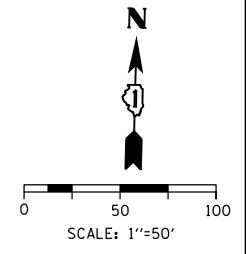

EX-02A-MP
EX-02B-MP
EX-02C-MP
REMOV SIN PAN ASSY TB
STA 5204+12.79

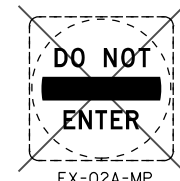

EX-02A-MP
R5-1 (30"x30")
FACING WEST

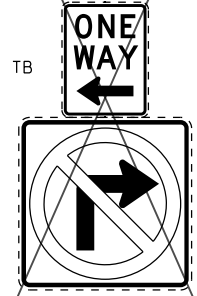

EX-02B-MP,
R6-2L (18"x24")
EX-02C-MP,
R3-2 (24"x24")
FACING EAST

EX-05-LP
W4-1R (48"x48")
REMOV SIGN PANEL T2
STA 5203+40.85

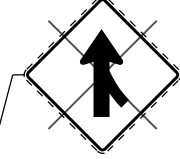

F WB-02-LP
W4-1R (48"x48")
SIGN PANEL T2
STA 5203+40.85



G WB-03-LP
R5-1100 (48"x60")
SIGN PANEL T2
STA 5201+96.51

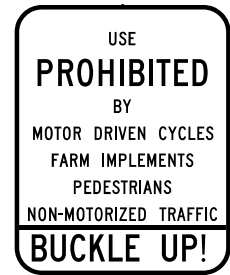

H TL-04A-MP (FACING WEST)
TL-04B-MP (FACING EAST)
TL-04C-MP
SIGN PANEL T1
STA 5204+12.79



R5-1 (30"x30")



R6-2L (18"x24")



R3-2 (24"x24")

I TL-05A-MP
TL-05B-MP
R7-NO PARKING
TOW ZONE (18"x18")
SIGN PANEL T1
STA 5203+77.70

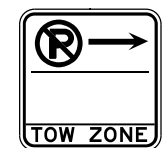
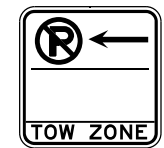

J TL-06A-MP
TL-06B-MP
R7-NO PARKING
TOW ZONE (18"x18")
SIGN PANEL T1
STA 5203+63.92



K TL-07-MP
R7-NO PARKING
TOW ZONE (18"x18")
SIGN PANEL T1
STA 5202+86.67

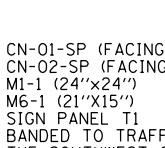

L CN-01-SP (FACING EAST)
CN-02-SP (FACING WEST)
M1-1 (24"x24")
M6-1 (21"x15")
SIGN PANEL T1
BANNED TO TRAFFIC SIGNAL POLE AT
THE SOUTHWEST CORNER OF
VAN BUREN STREET AND CANAL STREET

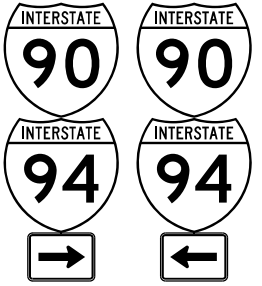

SIGN NUMBERING CODE EXAMPLE

DIRECTION OF TRAFFIC	NB-03-LP	MOUNTING TYPE
TL - TILDEN STREET		ST - STEEL POST
CN - CANAL STREET		TS - TELESCOPING STEEL
VN - VAN BUREN STREET		MP - METAL POST
WB - WESTBOUND I-290		LP - LIGHT POLE BANDING
EX - EXISTING		SP - SIGNAL POLE BANDING
		SA - SIGNAL POLE MAST ARM
		BM - BRIDGE MOUNTED
		PM - PARAPET MOUNTED
		PP - PEDESTRIAN PUSH BUTTON
		BS - BREAKAWAY STEEL
		WP - WOOD POST
		OV - OVERHEAD
		TM - SIGN TRUSS MOUNTED
		(S) - SPECIAL

SIGNING NOTES

- SEE SIGN SCHEDULE FOR SIGN PANEL AND MOUNTING INFORMATION.
- BEFORE BEGINNING ANY WORK, THE CONTRACTOR SHALL RECORD AND RETAIN ALL EXISTING SIGN INFORMATION FOR FUTURE REFERENCE. EXACT LOCATIONS OF ALL SIGNS SHALL BE DIRECTED BY THE ENGINEER. IT SHALL BE THE CONTRACTOR'S RESPONSIBILITY TO VERIFY ALL DIMENSIONS AND CONDITIONS IN THE FIELD PRIOR TO CONSTRUCTION AND ORDERING OF MATERIALS.
- THE CONTRACTOR SHALL CONTACT THE DISTRICT OF ARTERIAL TRAFFIC CONTROL SUPERVISOR AT (847) 705-4470 AND THE EXPRESSWAYS TRAFFIC CONTROL SUPERVISOR AT (847) 705-4155 A MINIMUM OF 72 HOURS IN ADVANCE OF BEGINNING WORK ON OVERHEAD SIGNS AND OVERHEAD SIGN STRUCTURES.

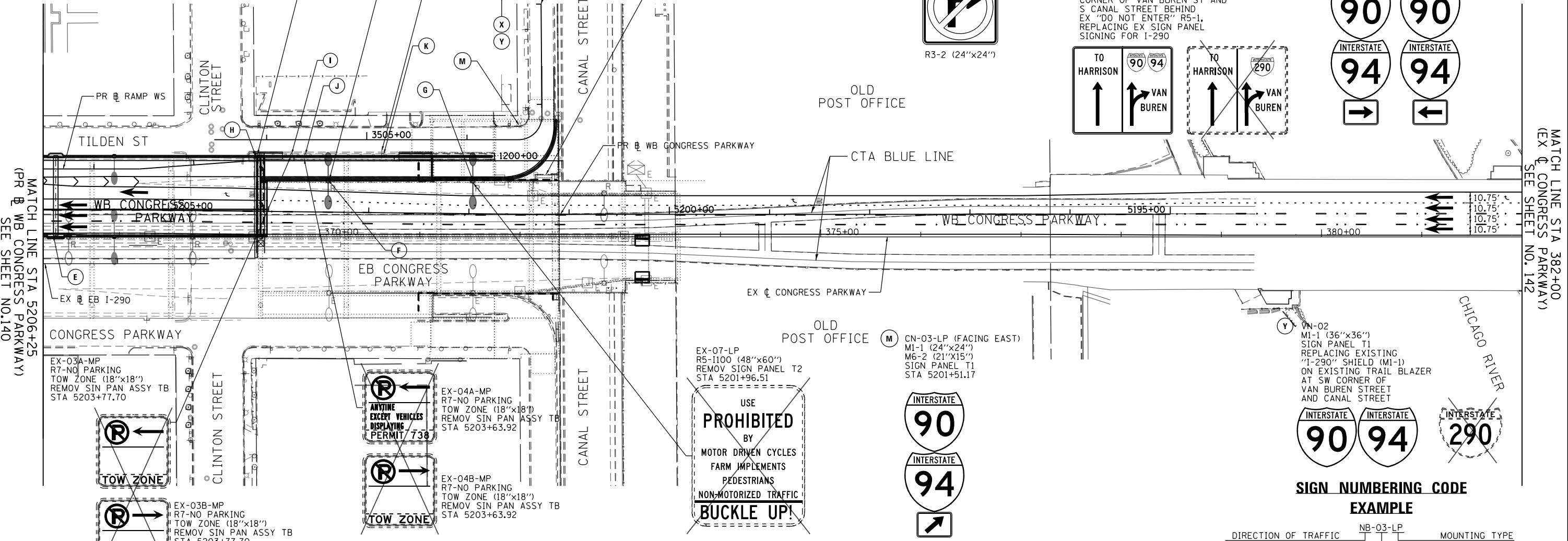

EX-03A-MP
R7-NO PARKING
TOW ZONE (18"x18")
REMOV SIN PAN ASSY TB
STA 5203+77.70

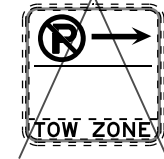
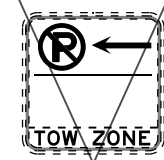

EX-03B-MP
R7-NO PARKING
TOW ZONE (18"x18")
REMOV SIN PAN ASSY TB
STA 5203+77.70

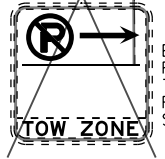
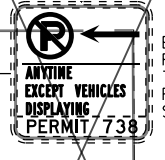

EX-04A-MP
R7-NO PARKING
TOW ZONE (18"x18")
REMOV SIN PAN ASSY TB
STA 5203+63.92

EX-04B-MP
R7-NO PARKING
TOW ZONE (18"x18")
REMOV SIN PAN ASSY TB
STA 5203+63.92

EX-07-LP
R5-1100 (48"x60")
REMOV SIGN PANEL T2
STA 5201+96.51

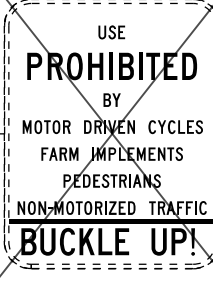

M CN-03-LP (FACING EAST)
M1-1 (24"x24")
M6-2 (21"x15")
SIGN PANEL T1
STA 5201+51.17



VN-02
M1-1 (36"x36")
SIGN PANEL T1
REPLACING EXISTING
"I-290" SHIELD (M1-1)
ON EXISTING TRAIL BLAZER
AT SW CORNER OF
VAN BUREN STREET
AND CANAL STREET



STA 5206+12
OVERHEAD SIGN
STRUCTURE - SPAN,
TYPE II-A
(4'-6" X 5'-3")
SEE OVERHEAD SIGN
STRUCTURE DETAILS

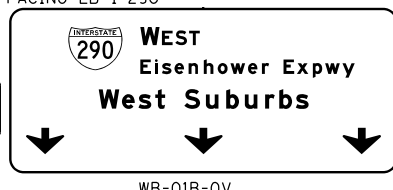

WB-01B-OV
SIGN PANEL T3

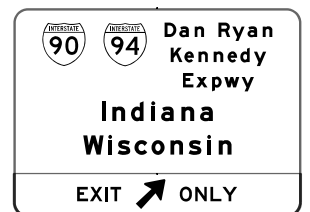

WB-01C-OV
SIGN PANEL T3



WB-01E-OV
SIGN PANEL T3

WB-01D-TM, W13-3 (48"x60")
SIGN PANEL T2



D16078-SHT-Sign-02.dgn	DESIGNED - OPS	REVISED -
USER NAME = dshevoz	DRAWN - OPS	REVISED -
PLOT SCALE = 100.0000' / in.	CHECKED - DBM	REVISED -
PLOT DATE = 4/27/2016	DATE - 3/18/2016	REVISED -

STATE OF ILLINOIS
DEPARTMENT OF TRANSPORTATION

SIGNING PLAN	
WB I-290 OVER I-90/94 AND WB CONGRESS PARKWAY	
SCALE: 1"=50'	SHEET 2 OF 3 SHEETS STA. 5206+25 TO STA. 382+00

F.A.I. R.T.E.	SECTION	COUNTY	TOTAL SHEETS	SHEET NO.
90/94/290	2014-004R&B	COOK	706	141
CONTRACT NO. 60X78				
ILLINOIS FED. AID PROJECT				

FILE PATH = p:\61779-PM\INT\pccom\line\local\AECOM_D902_NA\Documents\01_Americas\T-emp\station\60269938_Circle\Phase_11\000_CAD\006_Roadway\Sheets\60X78_Contract\016078-SHT-Sign-02.dgn

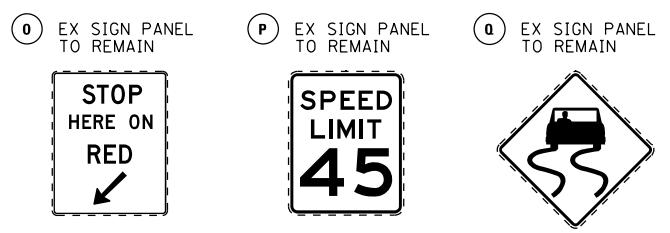
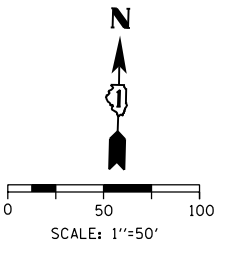

EXISTING SIGN PANEL TO REMAIN ON EXISTING OVERHEAD SIGN STRUCTURE

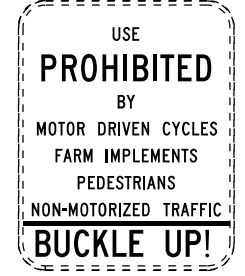
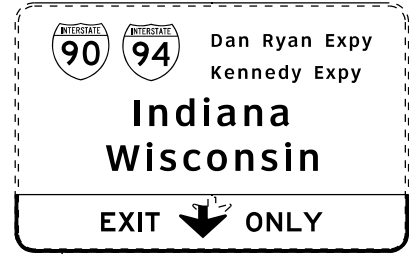
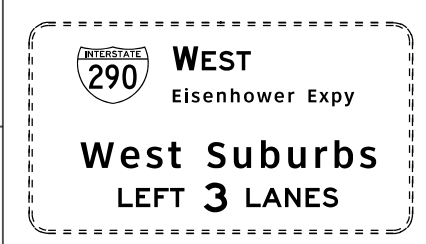

SIGN PANEL OVERLAY "EXIT, DOWN ARROW, ONLY" OVER EXISTING DOWN ARROW

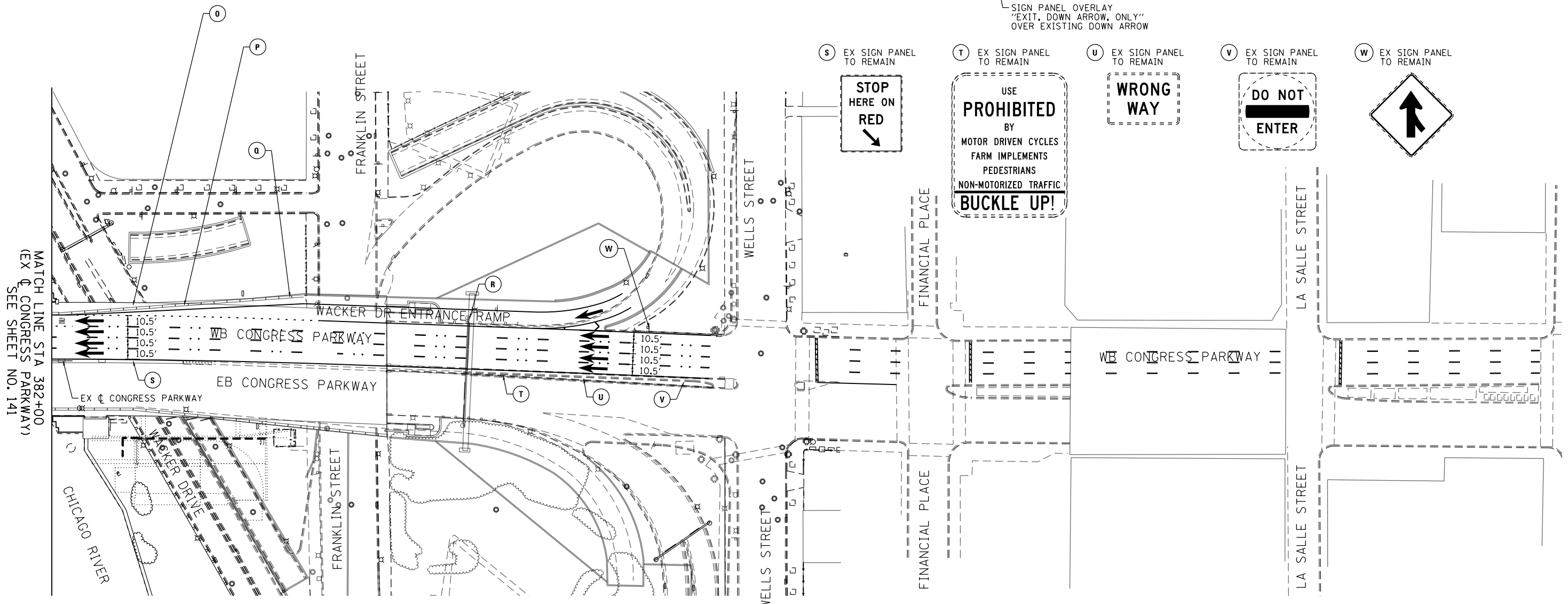
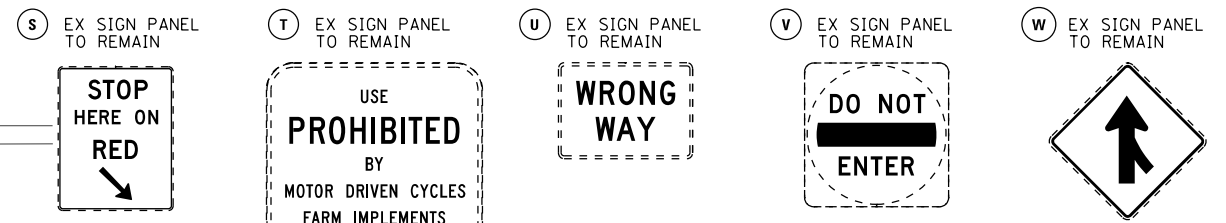

MATCH LINE STA 382+00 (EX Q CONGRESS PARKWAY) SEE SHEET NO. 141

SIGNING NOTES

- SEE SIGN SCHEDULE FOR SIGN PANEL AND MOUNTING INFORMATION.
- BEFORE BEGINNING ANY WORK, THE CONTRACTOR SHALL RECORD AND RETAIN ALL EXISTING SIGN INFORMATION FOR FUTURE REFERENCE. EXACT LOCATIONS OF ALL SIGNS SHALL BE DIRECTED BY THE ENGINEER. IT SHALL BE THE CONTRACTOR'S RESPONSIBILITY TO VERIFY ALL DIMENSIONS AND CONDITIONS IN THE FIELD PRIOR TO CONSTRUCTION AND ORDERING OF MATERIALS.
- THE CONTRACTOR SHALL CONTACT THE DISTRICT OF ARTERIAL TRAFFIC CONTROL SUPERVISOR AT (847) 705-4470 AND THE EXPRESSWAYS TRAFFIC CONTROL SUPERVISOR AT (847) 705-4155 A MINIMUM OF 72 HOURS IN ADVANCE OF BEGINNING WORK ON OVERHEAD SIGNS AND OVERHEAD SIGN STRUCTURES.

SIGN NUMBERING CODE EXAMPLE

DIRECTION OF TRAFFIC	NB-03-LP	MOUNTING TYPE
TL - TILDEN STREET		ST - STEEL POST
CN - CANAL STREET		TS - TELESCOPING STEEL
VN - VAN BUREN STREET		MP - METAL POST
WB - WESTBOUND I-290		LP - LIGHT POLE BANDING
EX - EXISTING		SP - SIGNAL POLE BANDING
SIGN PANEL NUMBER		SA - SIGNAL POLE MAST ARM
		BM - BRIDGE MOUNTED
		PM - PARAPET MOUNTED
		PP - PEDESTRIAN PUSH BUTTON
		BS - BREAKAWAY STEEL
		WP - WOOD POST
		OV - OVERHEAD
		TM - SIGN TRUSS MOUNTED
		(S) - SPECIAL

FILE PATH = p:\617479-PMINT\pccommon\line\local\AECOM_D902_NA\Documents\01_Americas\T\engor\station\60269438_Circle\Phase_11\000_CAD\006_Roadway\Sheets\60x78_Contract\0160x78-SHT-Sign-03.dgn



D160x78-SHT-Sign-03.dgn	DESIGNED - OPS	REVISED -
USER NAME = dshevoz	DRAWN - OPS	REVISED -
PLOT SCALE = 100.0000' / in.	CHECKED - DBM	REVISED -
PLOT DATE = 4/27/2016	DATE - 3/18/2016	REVISED -

STATE OF ILLINOIS
DEPARTMENT OF TRANSPORTATION

SIGNING PLAN
WB I-290 OVER I-90/94 AND WB CONGRESS PARKWAY
SCALE: 1"=50' SHEET 3 OF 3 SHEETS STA. 382+00 TO STA.

F.A.I. RTE.	SECTION	COUNTY	TOTAL SHEETS	SHEET NO.
90/94/290	2014-004R&B	COOK	706	142
CONTRACT NO. 60X78				
ILLINOIS FED. AID PROJECT				

FILE PATH = p:\6179-PMINT\ecommon\line\locat\AECOM_D902_NA\Documents\01_Americas\T\engor\station\60269938_Circle\Phase_1\000_CAD\006_Roadway\Sheets\60X78_Contract\0160X78-SHT-Sign-Det-01.dgn

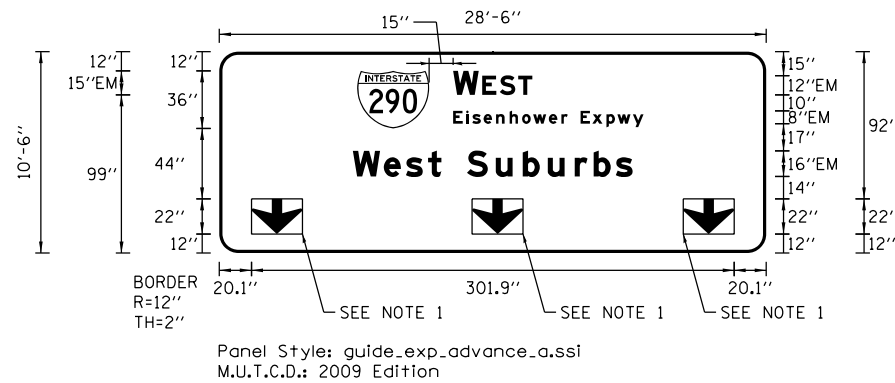

Panel Style: guide_exp_advance_a.ssi
 Dimensions are in inches.tenths

Letter locations are panel edge to lower left corner

SIGN NUMBER	WB-01B-OV
WIDTH x HGHT.	28'-6" x 10'-6"
BORDER WIDTH	2"
CORNER RADIUS	12"
MOUNTING	Overhead
BACKGROUND	TYPE: ZZ Retro-Reflective
	COLOR: Green
LEGEND/BORDER	TYPE: ZZ Retro-Reflective
	COLOR: WhiteWhite

SYMBOL	ROT	X	Y	WID	HT
MI_1	0	86.2	78	45	36
ARROWN	0	20.1	12	32	22
ARROWN	0	158.1	12	32	22
ARROWN	0	290.1	12	32	22

LETTER POSITIONS (X)																LENGTH	SERIESSIZE
W	E	S	T														EM 2000
146.2	164.3	175.4	186.9														49.5
E	i	s	e	n	h	o	w	e	r		E	x	p	w	y		EM 2000
146.2	154.3	158.2	165.3	173	181.5	189.3	196.3	206.1	213.8	217.8	225.8	233.2	242.1	249	258.6		119.1
W	e	s	t		S	u	b	u	r	b	s						EM 2000
83.6	102.9	116.7	130.6	138.9	154.9	172.8	189.8	205.3	222.3	234.1	247.9						174.9

NOTE:
 1. ALL ARROWS (DOWN OR 45°) USED ON OVERHEAD SIGNS SHALL BE DEMOUNTABLE. THE COST OF THE DEMOUNTABLE ARROWS SHALL BE INCLUDED IN THE COST OF THE SIGN PANEL.



0160X78-SHT-Sign-Det-01.dgn
 USER NAME = dshevoz
 PLOT SCALE = 10.0000 / in.
 PLOT DATE = 4/27/2016

DESIGNED - OPS
 DRAWN - OPS
 CHECKED - DBM
 DATE - 3/18/2016

REVISED -
 REVISED -
 REVISED -
 REVISED -

STATE OF ILLINOIS
 DEPARTMENT OF TRANSPORTATION

SIGNING DETAILS

SCALE: NONE SHEET 1 OF 2 SHEETS STA. TO STA.

F.A.I. RTE.	SECTION	COUNTY	TOTAL SHEETS	SHEET NO.
90/94/290	2014-004R&B	COOK	706	143
CONTRACT NO. 60X78			ILLINOIS FED. AID PROJECT	

FILE PATH = p:\6179-PMINT\ecomom\line\loc\IPE\CDM_D902_NA\Documents\01_Americas\T_engor\station\60269938_Circle\Phase_11\000_CAD\006_Roadway\Sheets\60X78_Contract\0160X78-SHT-Sign-Det-02.dgn

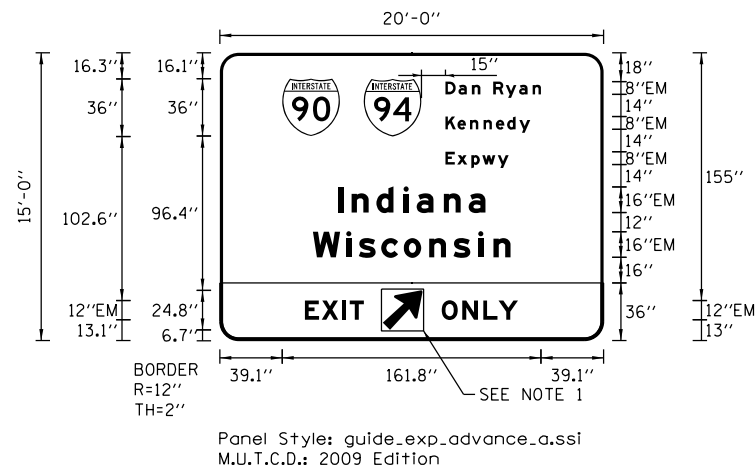

Panel Style: guide_exp_advance_a.ssi
 Dimensions are in inches.tenths

Letter locations are panel edge to lower left corner

SIGN NUMBER	WB-01C-OV
WIDTH x HGHT.	20'-0" x 15'-0"
BORDER WIDTH	2"
CORNER RADIUS	12"
MOUNTING	Overhead
BACKGROUND	TYPE: ZZ Retro-Reflective
	COLOR: Green
LEGEND/BORDER	TYPE: ZZ Retro-Reflective
	COLOR: White /BlackWhite

SYMBOL	ROT	X	Y	WID	HT
M1_1	0	39.1	127.9	36	36
M1_1	0	90.1	127.7	36	36
AR_Type A	315	101.9	6.6	20	31.5

LETTER POSITIONS (X)																	LENGTH	SERIES/SIZE
D	a	n		R	y	a	n										EM 2000	
141.1	149.2	157.7	163	171	178.8	187.2	195.6										59.8	86
K	e	n	n	e	d	y												EM 2000
141.1	148.7	156.4	164.9	172.7	179.7	187.3											53.1	86
E	x	p	w	y														EM 2000
141.1	148.4	157.3	164.2	173.8													39.5	86
I	n	d	i	a	n	a												EM 2000
73.9	82.5	98	115	123.1	140.1	155.6											92.3	1612
W	i	s	c	o	n	s	i	n										EM 2000
58.3	79.1	86.9	101	115.1	130.9	146.1	161.6	171.2									123.5	1612
E	X	I	T															EM 2000
53.2	63.7	76.7	81.3														37	12
O	N	L	Y															EM 2000
138.7	151.7	164.8	174.4														47.8	12

NOTE:
 1. ALL ARROWS (DOWN OR 45°) USED ON OVERHEAD SIGNS SHALL BE DEMOUNTABLE. THE COST OF THE DEMOUNTABLE ARROWS SHALL BE INCLUDED IN THE COST OF THE SIGN PANEL.



D160X78-SHT-Sign-Det-02.dgn
 USER NAME = dshevoz
 PLOT SCALE = 10.0000' / in.
 PLOT DATE = 4/27/2016

DESIGNED - OPS
 DRAWN - OPS
 CHECKED - DBM
 DATE - 3/18/2016

REVISED -
 REVISED -
 REVISED -
 REVISED -

STATE OF ILLINOIS
 DEPARTMENT OF TRANSPORTATION

SIGNING DETAILS

SCALE: NONE SHEET 2 OF 3 SHEETS STA. TO STA.

F.A.I. RTE.	SECTION	COUNTY	TOTAL SHEETS	SHEET NO.
90/94/290	2014-004R&B	COOK	706	144
CONTRACT NO. 60X78				
ILLINOIS FED. AID PROJECT				

FILE PATH = p:\61779-PMINT\secomon\line\local\AECOM\01_Americas\T_engor\station\60269938_Circle\Phase_11\000_CAD\006_Roadway\Sheets\60X78_Contract\0160X78-SHT-Sign-Det-03.dgn



Panel Style: regulatory.ssi
Dimensions are in inches.tenths
Letter locations are panel edge to lower left corner

LETTER POSITIONS (X)										LENGTH	SERIESSIZE
A	C	C	E	S	S		T	O			E 2000
11.1	22.7	32.8	43.2	52.1	61.6	69.7	79.7	88.6		85.9	10
P	R	O	H	I	B	I	T	E	D		E 2000
11.1	20.9	30.7	41.4	52.1	56.5	66.6	70.1	79.3	88.8	85.8	10

SIGN NUMBER	WB-01E-OV
WIDTH x HGHT.	9'-0" x 8'-0"
BORDER WIDTH	0.63"
CORNER RADIUS	1.13"
MOUNTING	Overhead
BACKGROUND	TYPE: ZZ Retro-Reflective COLOR: White
LEGENDBORDER	TYPE: ZZ Retro-Reflective COLOR: White/Black

SYMBOL	ROT	X	Y	WID	HT
MI_1	0	31.5	30	45	36

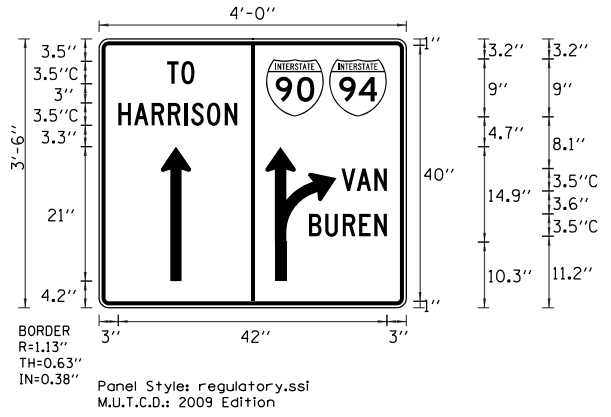

Panel Style: regulatory.ssi
Dimensions are in inches.tenths
Letter locations are panel edge to lower left corner

LETTER POSITIONS (X)										LENGTH	SERIESSIZE
T	O										C 2000
10.6	12.8									4.3	3.5
H	A	R	R	I	S	O	N				C 2000
3	5.5	8.2	10.8	13.3	14.4	16.9	19.6			18.6	3.5
V	A	N									C 2000
37.9	40.3	43								7.1	3.5
B	U	R	E	N							C 2000
32.8	35.4	38.1	40.6	43						12.2	3.5

SIGN NUMBER	VN-01-MP
WIDTH x HGHT.	4'-0" x 3'-6"
BORDER WIDTH	0.63"
CORNER RADIUS	1.13"
MOUNTING	Ground
BACKGROUND	TYPE: AP Reflective COLOR: White
LEGENDBORDER	TYPE: AP Reflective COLOR: Black/Black

SYMBOL	ROT	X	Y	WID	HT
MI_1	0	26.1	29.9	9	9
MI_1	0	36	29.9	9	9
R3_6A (MOD)	180	26	10.3	11.1	21
AR_Type D	0	10.5	4.2	3	21



D160X78-SHT-Sign-Det-03.dgn
USER NAME = dshevoz
PLOT SCALE = 2.5000' / in.
PLOT DATE = 4/27/2016

DESIGNED - OPS	REVISED -
DRAWN - OPS	REVISED -
CHECKED - DBM	REVISED -
DATE - 3/18/2016	REVISED -

STATE OF ILLINOIS
DEPARTMENT OF TRANSPORTATION

SIGNING DETAILS
SCALE: NONE SHEET 3 OF 3 SHEETS STA. TO STA.

F.A.I. RTE.	SECTION	COUNTY	TOTAL SHEETS	SHEET NO.
90/94/290	2014-004R&B	COOK	706	145
CONTRACT NO. 60X78				
ILLINOIS FED. AID PROJECT				

FILE PATH = p:\61779-PMINT\aecon\line\local\AECDM_0502_NA\Documents\01_Americas\T\engp\station\60269438_Circle\Phase_1\1000_CAD\006_Roadway\Sheets\60X78_Contract\0160X78-SHT-Sign-OH-01.dgn

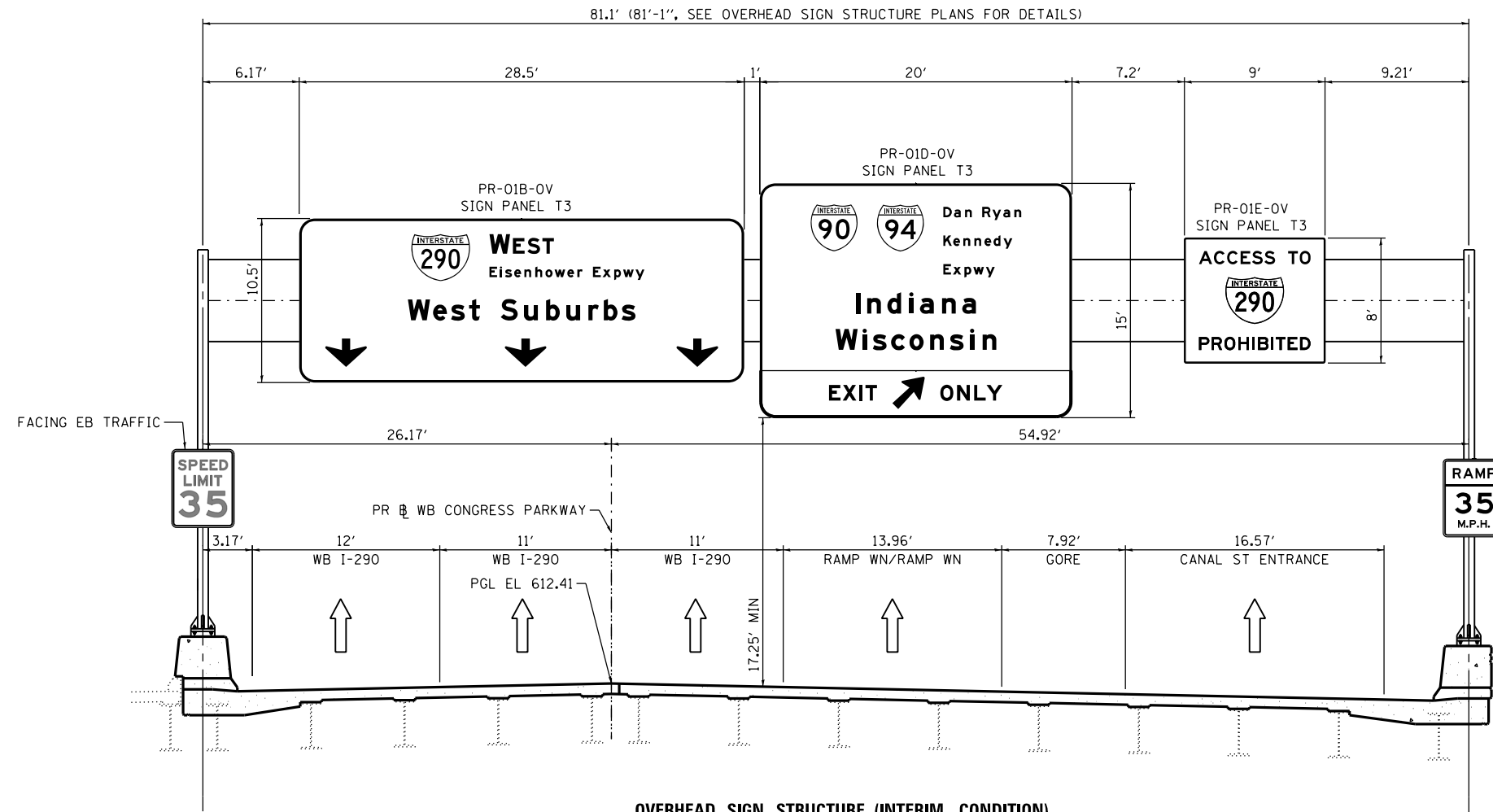

OVERHEAD SIGN STRUCTURE (INTERIM CONDITION)
STA 5206+12.43
PR WB I-290



D160X78-SHT-Sign-OH-01.dgn	DESIGNED - OPS	REVISED -
USER NAME = dshevoz	DRAWN - OPS	REVISED -
PLOT SCALE = 10.0000' / in.	CHECKED - DBM	REVISED -
PLOT DATE = 4/27/2016	DATE - 3/18/2016	REVISED -

STATE OF ILLINOIS
DEPARTMENT OF TRANSPORTATION

SIGN PLACEMENT DETAILS

SCALE: N.T.S. SHEET 1 OF 1 SHEETS STA. TO STA.

F.A.I. RTE.	SECTION	COUNTY	TOTAL SHEETS	SHEET NO.
90/94/290	2014-004R&B	COOK	706	146
CONTRACT NO. 60X78			ILLINOIS FED. AID PROJECT	

GENERAL NOTES

DESIGN: AASHTO Standard Specifications for Structural Supports for Highway Signs, Luminaires and Traffic Signals. ("AASHTO Specifications")

CONSTRUCTION: Current (at time of letting) Illinois Department of Transportation Standard Specifications for Road and Bridge Construction, Supplemental Specifications and Special Provisions. ("Standard Specifications")

LOADING: 90 M.P.H. WIND VELOCITY

DESIGN STRESSES:
Field Units
f_c = 3,500 p.s.i.
f_y = 60,000 p.s.i. (reinforcement)

WELDING: All welds to be continuous unless otherwise shown. All welding to be done in accordance with current AWS D1.1 and D1.2 Structural Welding Codes (Steel and Aluminum) and the Standard Specifications.

MATERIALS: Aluminum Alloys as shown throughout plans. All Structural Steel Pipe shall be ASTM A53 Grade B or A500 Grade B or C. If A500 pipe is substituted for A53, then the outside diameter shall be as detailed and wall thickness greater than or equal to A53. All Structural Steel Plates and Shapes shall conform to AASHTO M270 Gr. 36, Gr. 50 or Gr. 50W*. Stainless steel for shims, sleeves and handhole covers shall be ASTM A240, Type 302 or 304, or another alloy suitable for exterior exposure and acceptable to the Engineer.

The steel pipe and stiffening ribs at the base plate for the column shall have a minimum longitudinal Charpy V-Notch (CVN) energy of 15 lb.-ft. at 40° F. (Zone 2) before galvanizing.

FASTENERS FOR ALUMINUM TRUSSES: All bolts noted as "high strength" must satisfy the requirements of AASHTO M164 (ASTM A325), or approved alternate, and must have matching lock nuts. Threaded studs for splices (if Members interfere) must satisfy the requirements of ASTM A449, ASTM A193, Grade B7, or approved alternate, and must have matching lock nuts. Bolts and lock nuts not required to be high strength must satisfy the requirements of ASTM A307. All bolts and lock nuts must be hot dip galvanized per AASHTO M232. The lock nuts must have nylon or steel inserts. A stainless steel flat washer conforming to ASTM A240 Type 302 or 304, is required under both head and nut or under both nuts where threaded studs are used. High strength bolt installation shall conform to Article 505.04 (f) (2)d of the IDOT Standard Specifications for Road and Bridge Construction. Rotational capacity ("ROCAP") testing of bolts will not be required.

U-BOLTS AND EYEBOLTS: U-Bolts and Eyebolts must be produced from ASTM A276 Type 304, 304L, 316 or 316L, Condition A, cold finished stainless steel, or an equivalent material acceptable to the Engineer. All nuts for U-Bolts and Eyebolts must be lock nuts equivalent to ASTM A307 with nylon or steel inserts and hot dip galvanized per AASHTO M232. A stainless steel flat washer conforming to ASTM A240, Type 302 or 304, is required under each U-Bolt and Eyebolt lock nut.

GALVANIZING: All Steel Grating, Plates, Anchor Rods, Shapes and Pipe shall be Hot Dip Galvanized after fabrication in accordance with AASHTO M111. Painting is not permitted.



Signed **Jamal Grainawi**
JAMAL I. GRAINAWI, S.E. II. Lic. No. 081-005161
Expires 11-30-2016
Date **3/18/2016**

TOTAL BILL OF MATERIAL

ITEM	UNIT	TOTAL
OVERHEAD SIGN STRUCTURE SPAN TYPE III-A	Foot	82

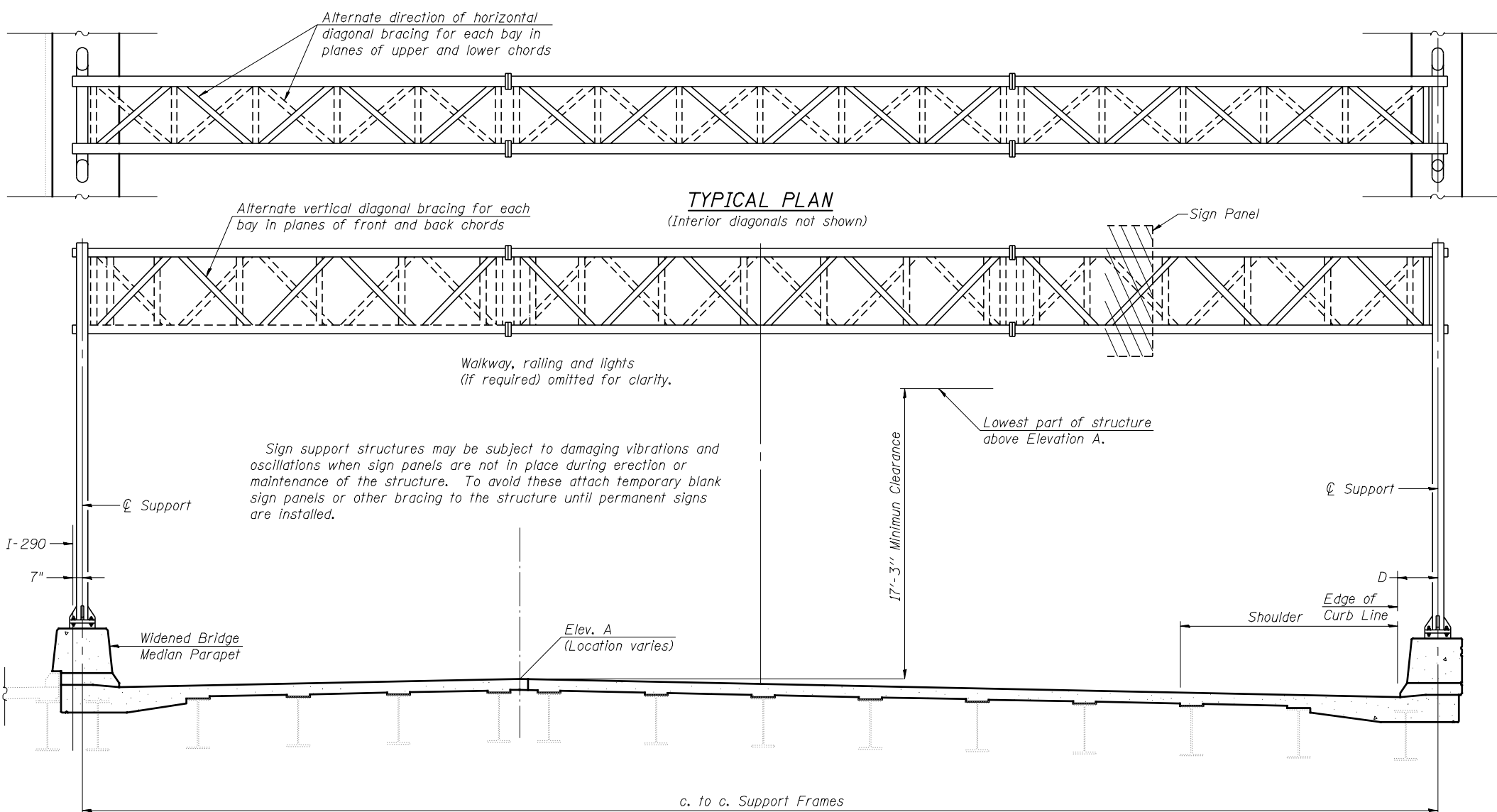

TYPICAL ELEVATION

(Looking West at Face of Signs)

Elev. A = Elevation at point of minimum clearance to sign, walkway support or truss.

Structure Number	Station	Design Truss Type	c. to c. Supports	Elev. A	Dim. D at Left Support	Dim. D at Right Support	Height of Tallest Sign	Total Sign Area
ISO16I290L000.0-002	5206+12.43 (Interim Location)	III-A	81'-1"	612.41	2'-2 1/2"	2'-3"	15'-0"	672 SQ FT
	5209+18.43 (Final Location)**	III-A	81'-1"	612.83	2'-2 1/2"	2'-3"	15'-0"	693 SQ FT

* If M270 Gr. 50W (M222) steel is proposed, chemistry for plate to be used shall first be approved by the Engineer as suitable for galvanizing and welding.

** Final location and other miscellaneous data provided for information only. Sign structure to be relocated in future contract (by others).

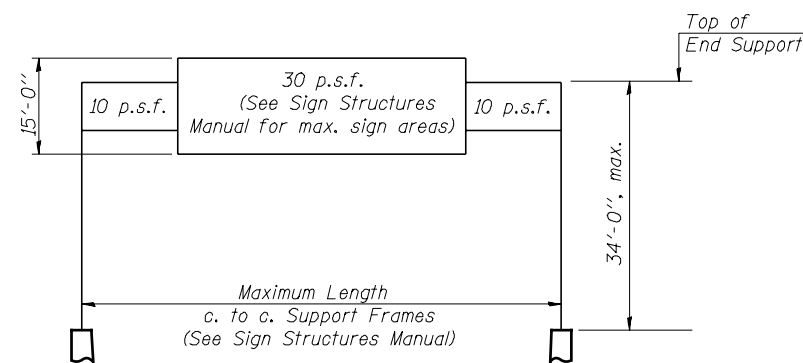

DESIGN WIND LOADING DIAGRAM

Parameters shown are basis for I.D.O.T. Standards and Sign Manual Tables. Installations not within dimensional limits shown require special analysis for all components.

60X78_SignStructure_Sheet1.dgn

PARSONS BRINCKERHOFF

USER NAME = lopezgonzalez	DESIGNED - PJL	REVISED -
	CHECKED - AH	REVISED -
PLLOT SCALE = N.T.S.	DRAWN - PJL	REVISED -
PLLOT DATE = 4/27/2016	CHECKED - JIG	REVISED -

**STATE OF ILLINOIS
DEPARTMENT OF TRANSPORTATION**

**OVERHEAD SIGN STRUCTURES - GENERAL PLAN &
ELEVATION - ALUMINUM TRUSS & STEEL SUPPORTS**

SHEET NO. 0H-1 OF 0H-8 SHEETS

F.A.I. RTE.	SECTION	COUNTY	TOTAL SHEETS	SHEET NO.
90/94/290	2014-004 R&B (WB)	COOK	706	147
			CONTRACT NO. 60X78	
ILLINOIS FED. AID PROJECT				

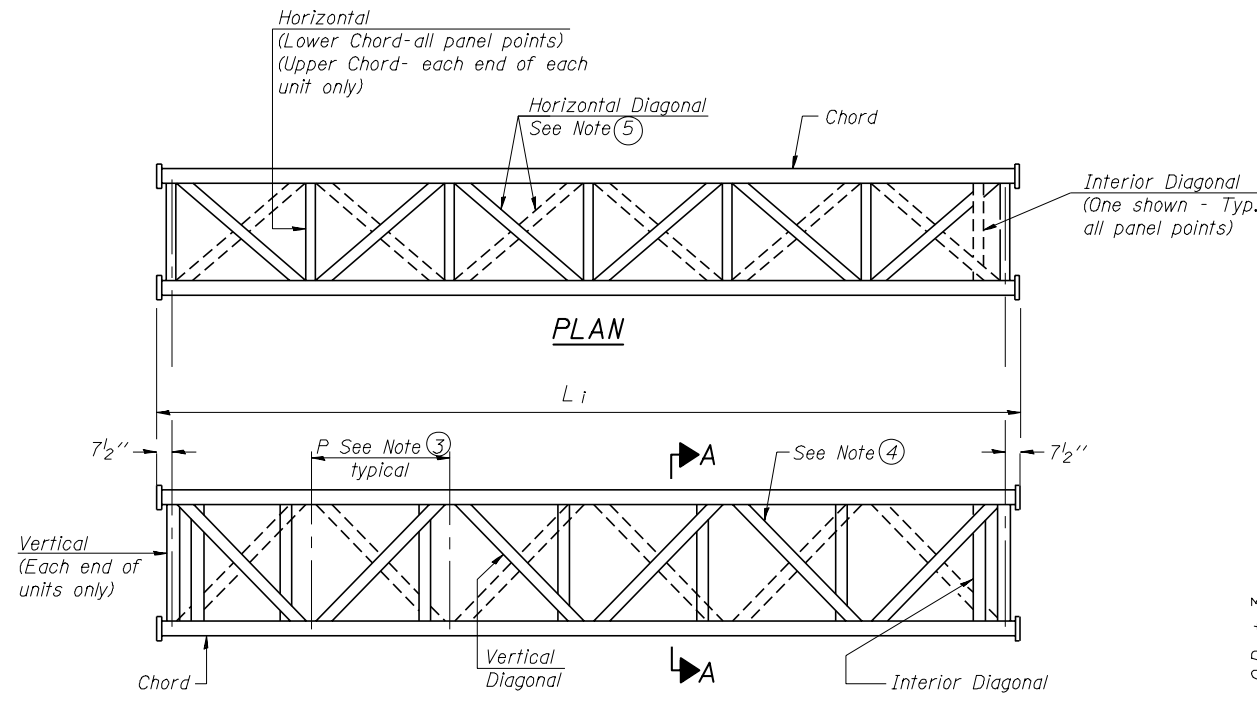

**ELEVATION
TYPICAL INTERIOR UNIT**
Even number of panels/interior unit required.

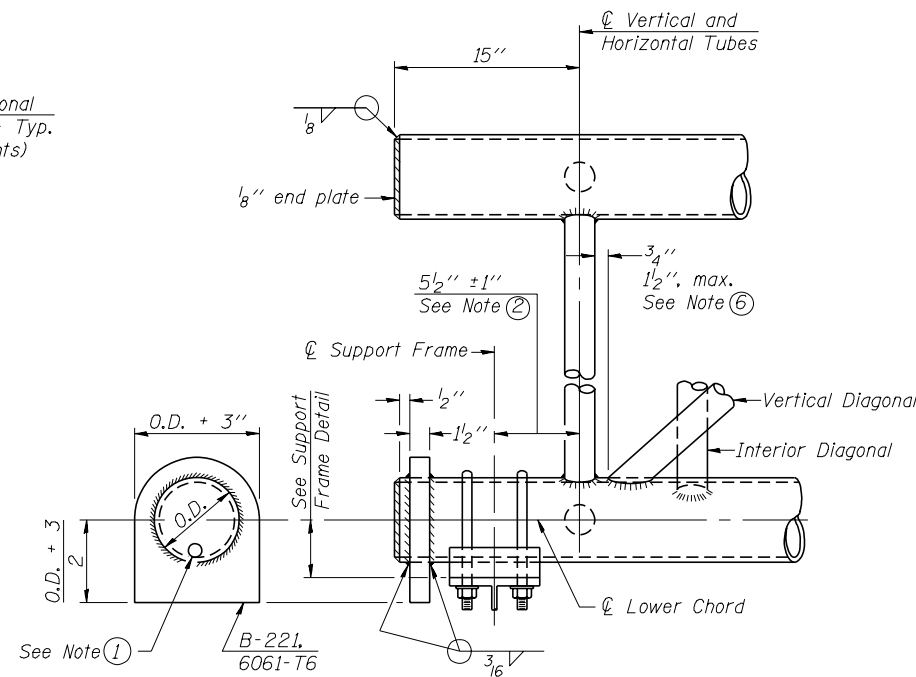

SUPPORT END DETAIL FOR EXTERIOR UNIT

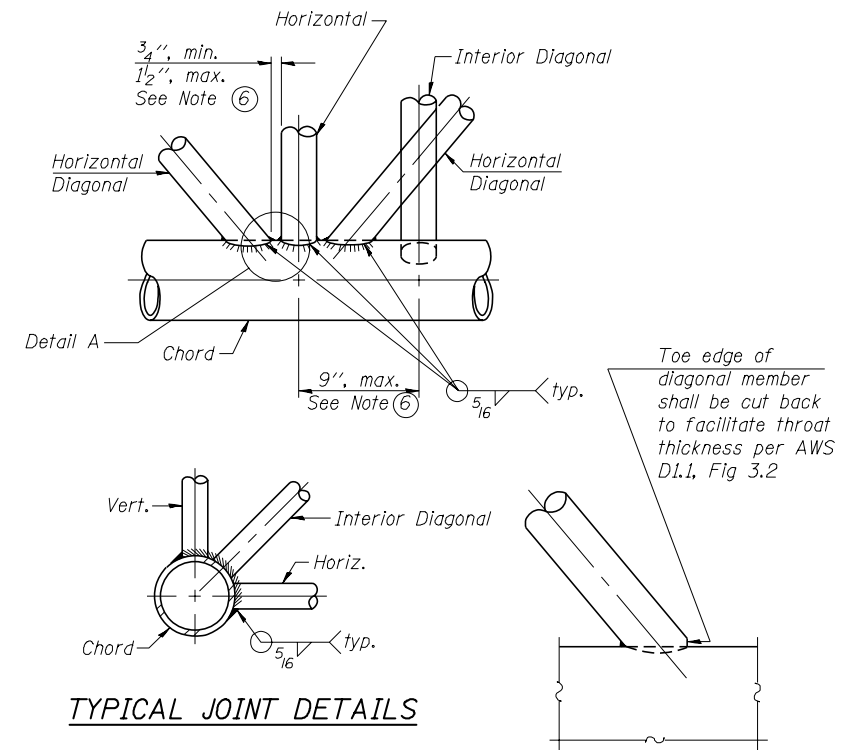

TYPICAL JOINT DETAILS

DETAIL A

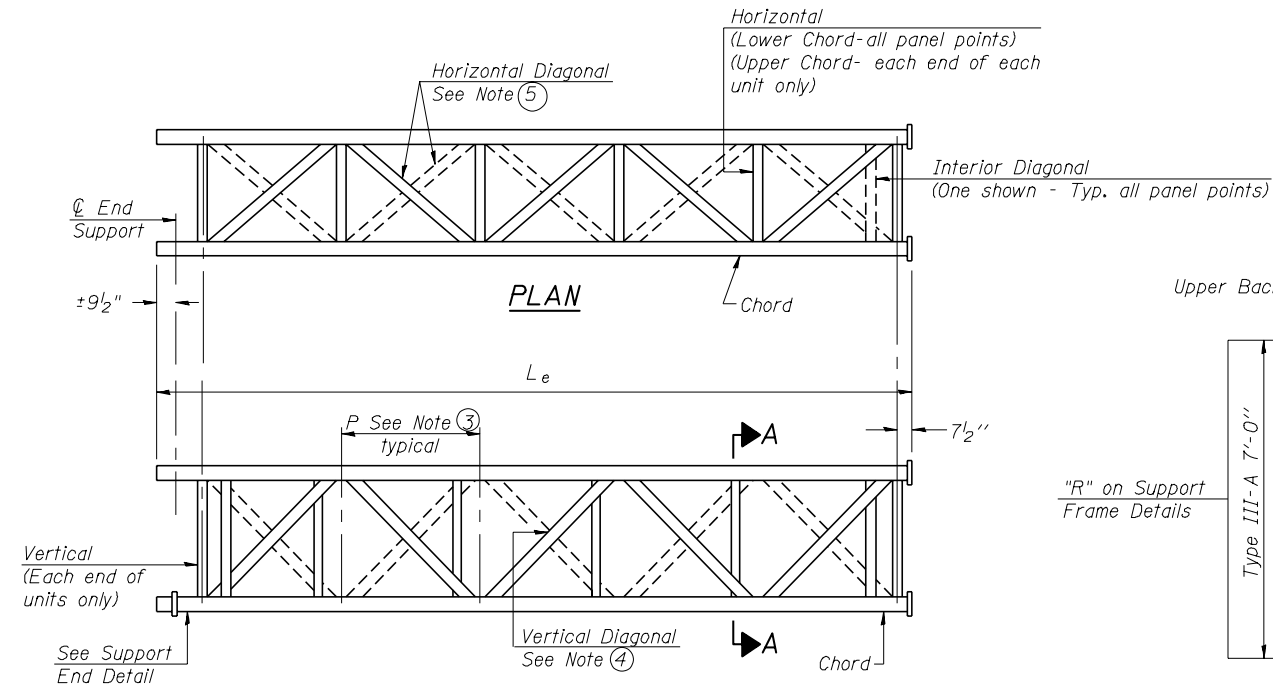

**ELEVATION
TYPICAL EXTERIOR UNIT**
Even or odd number of panels/exterior units allowed.

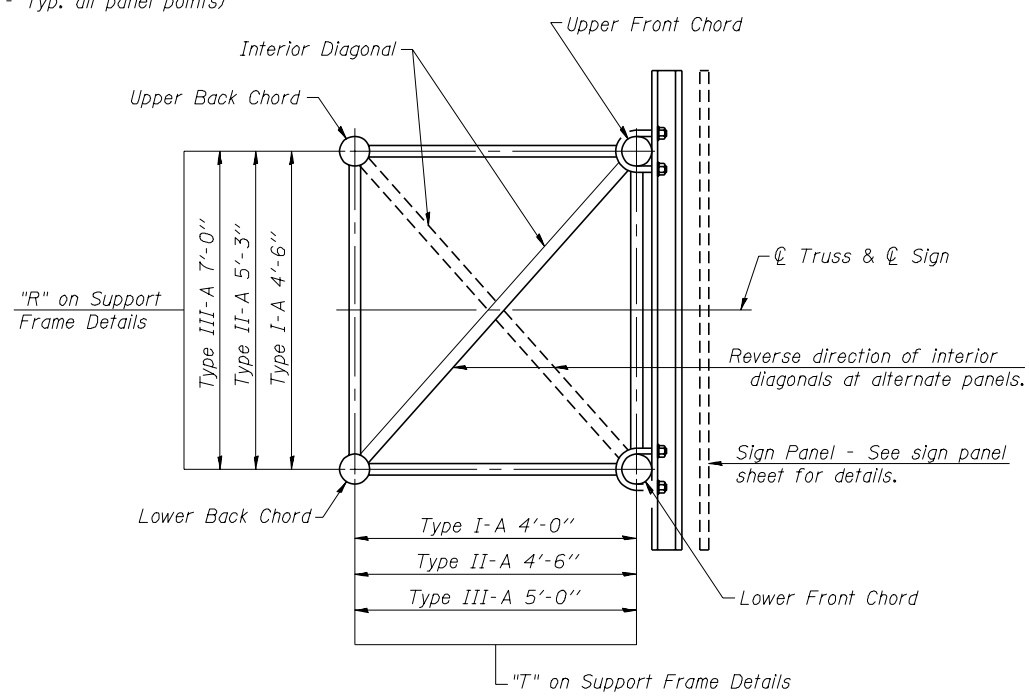

SECTION A-A

- ① Contractor may alternatively use standard aluminum drive-fit cap to close end. 1/2" φ drain hole in end plate/drive-fit cap. (Typ. at ends of all chords)
- ② 5 1/2" end dimension may vary by ±1" to provide uniform panel spacing (P).
- ③ Panel spacing (P) shall be uniform for entire truss and between 4'-0" and 5'-0" for Type I-A or 4'-0" and 5'-6" for Types II-A and III-A.
- ④ Vertical Diagonals in front and back face shall alternate.
- ⑤ Hidden lines show wind bracing alternates direction between planes of top and bottom chords.
- ⑥ All diagonals shall be detailed for minimum offset from the panel point based on the following: Offset shall be such as to provide a 3/4" minimum to 1 1/2" maximum clearance between any diagonal and any horizontal or vertical member, and to provide clearance for U-bolt connections of signs or walkway brackets.

60X78_SignStructure_Sheet2.dgn

**PARSONS
BRINCKERHOFF**

USER NAME =	lopezgonzalez	DESIGNED -	PJL	REVISED -	
		CHECKED -	AH	REVISED -	
PLOT SCALE =	N.T.S.	DRAWN -	PJL	REVISED -	
PLOT DATE =	4/27/2016	CHECKED -	JIG	REVISED -	

**STATE OF ILLINOIS
DEPARTMENT OF TRANSPORTATION**

**OVERHEAD SIGN STRUCTURES - ALUMINUM TRUSS
DETAILS FOR TRUSS TYPES I-A, II-A AND III-A**

SHEET NO. 0H-2 OF 0H-8 SHEETS

F.A.I. RTE.	SECTION	COUNTY	TOTAL SHEETS	SHEET NO.
90/94/290	2014-004 R&B (WB)	COOK	706	148
CONTRACT NO. 60X78				
ILLINOIS FED. AID PROJECT				

TRUSS UNIT TABLE

Structure Number	Station	Design Truss Type	Exterior Units (2)			Interior Unit				Upper & Lower Chord		Verticals; Horizontals; Vertical, Horizontal, and Interior Diagonals		Camber at Midspan	Splicing Flange					
			No. Panels per Unit	Unit Lgth.(L _u)	Panel Lgth.(P)	No. Req'd.	No. Panels per Unit	Unit Lgth.(L _i)	Panel Lgth.(P)	O.D.		O.D.			Bolts		Weld Sizes		A	B
										W	W ₁	W	W ₁		No./Splice	Dia.	W	W ₁		
ISO16I290R000.0-002	5209+12.43*	III-A	5	26'-5 1/2"	4'-11"	1	6	30'-9"	4'-11"	7"	5/16"	3 1/4"	5/16"	1 1/2"	6	1"	7/16"	5/16"	11 1/2"	15"

* Station for interim location shown. Sign structure to be relocated in future contract (by others).

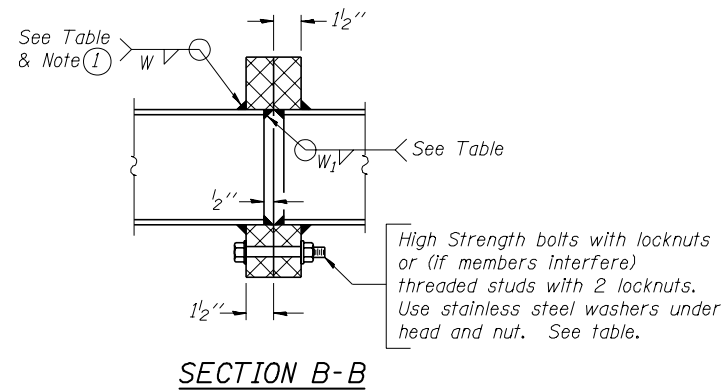

① Splicing Flanges shall be attached to each truss unit with the truss shop assembled to camber shown. Truss units shall be in proper alignment and flange surfaces shall be shop bolted into full contact before welding. Sufficient external welds or tacks shall be made to secure flanges until remaining welds are made after disassembly. Adjacent flanges shall be "match marked" to insure proper field assembly.

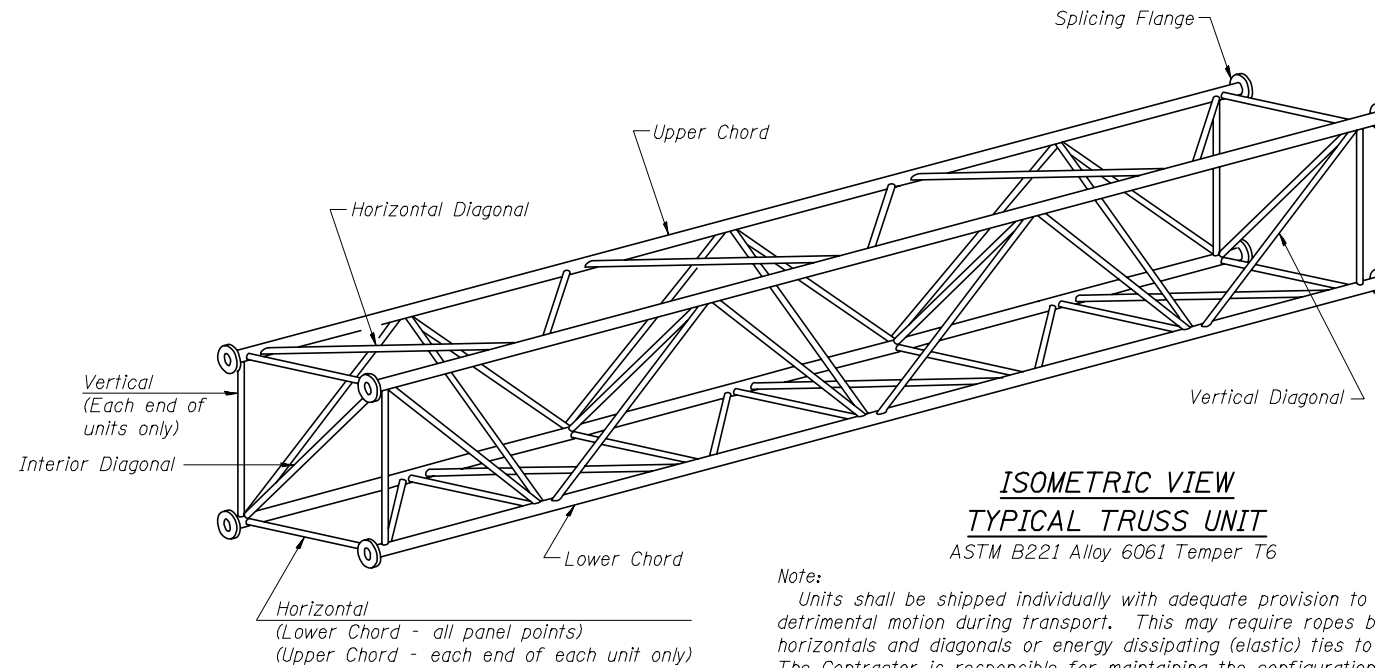

Note:
Units shall be shipped individually with adequate provision to prevent detrimental motion during transport. This may require ropes between horizontals and diagonals or energy dissipating (elastic) ties to the vehicle. The Contractor is responsible for maintaining the configuration and protection of the units.

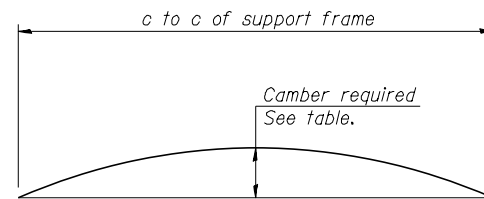

Camber curve shown is theoretical. Actual camber attained by slope changes at splices between units.

CAMBER ATTAINMENT EXAMPLES:

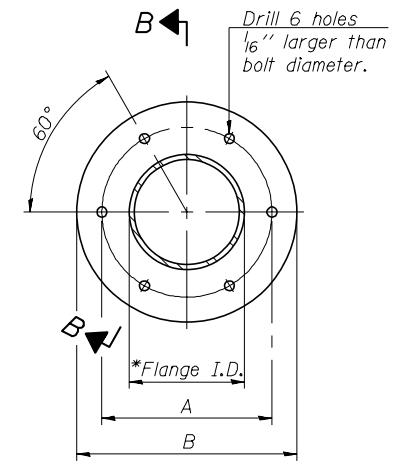
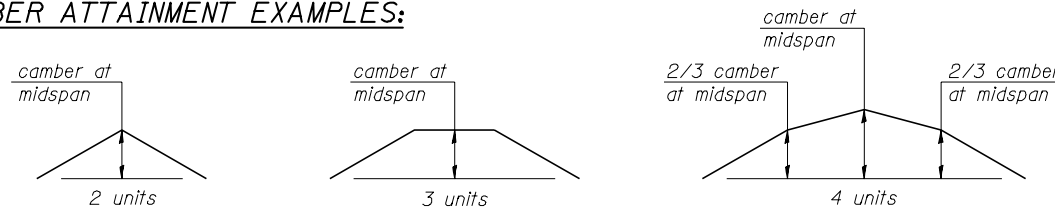

TRUSS TYPES I-A, II-A, & III-A

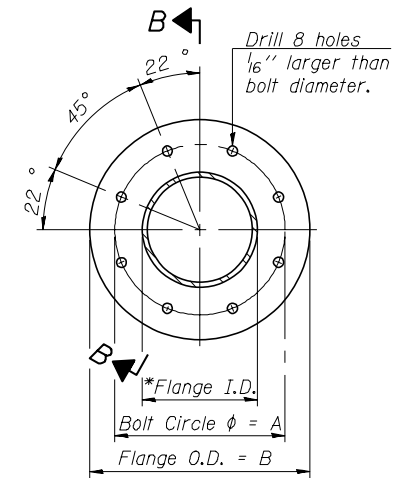

TRUSS TYPES II-A & III-A

SPLICING FLANGES

ASTM B221, Alloy 6061-T6 or ASTM B209, Alloy 6061-T651

*To fit O.D. of Chord with maximum gap of 1/16".

60X78_SignStructure_Sheet3.dgn

**PARSONS
BRINCKERHOFF**

USER NAME =	lopezgonzalez	DESIGNED -	PJL	REVISED -	
		CHECKED -	AH	REVISED -	
PLOT SCALE =	N.T.S.	DRAWN -	PJL	REVISED -	
PLOT DATE =	4/27/2016	CHECKED -	JIG	REVISED -	

**STATE OF ILLINOIS
DEPARTMENT OF TRANSPORTATION**

**OVERHEAD SIGN STRUCTURES - ALUMINUM TRUSS
DETAILS FOR TRUSS TYPES I-A, II-A AND III-A**

SHEET NO. 0H-3 OF 0H-8 SHEETS

F.A.I. RTE.	SECTION	COUNTY	TOTAL SHEETS	SHEET NO.
90/94/290	2014-004 R&B (WB)	COOK	706	149
			CONTRACT NO. 60X78	
ILLINOIS FED. AID PROJECT				

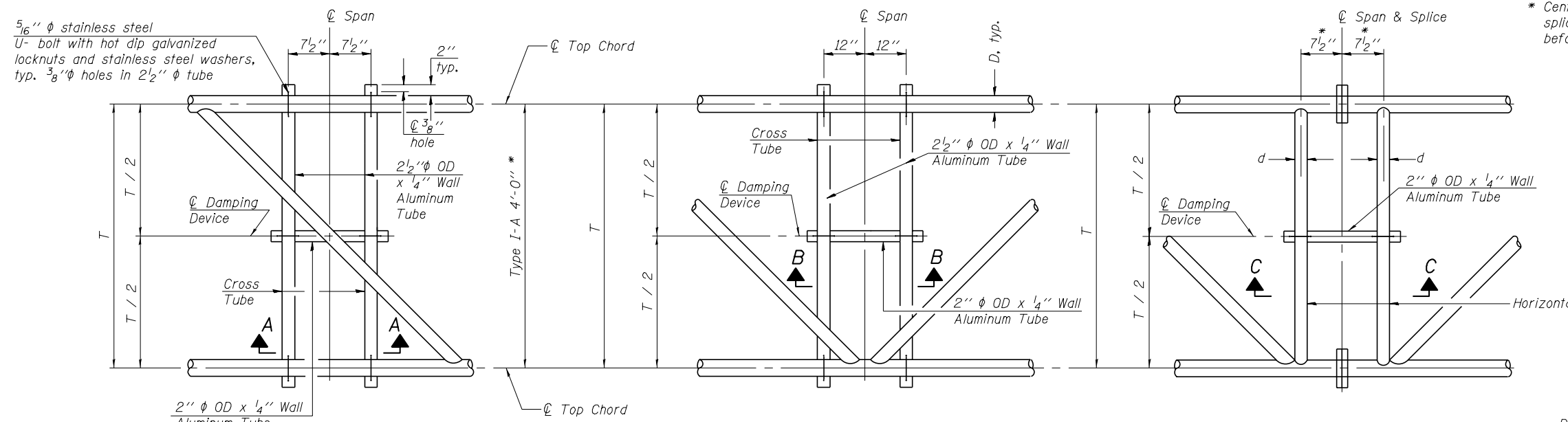

* Center of horizontal to center of splice dimension may vary. Verify before drilling holes in mounting tube.

PLAN DETAIL "A"
 ☐ Span between Panel Points

PLAN DETAIL "B"
 ☐ Span at Panel Point

PLAN DETAIL "C"
 ☐ Span at ☐ Chord Splice

NOTES

Damper: One damper per truss. (31 lbs. minimum Stockbridge-Type Aluminum - 29" minimum between ends of weights) Cost included in Overhead Sign Structure Span Type III-A.

Materials: Materials: Aluminum tubes shall be ASTM B221 alloy 6061 temper T6. Cost included in Overhead Sign Structure Span Type III-A.

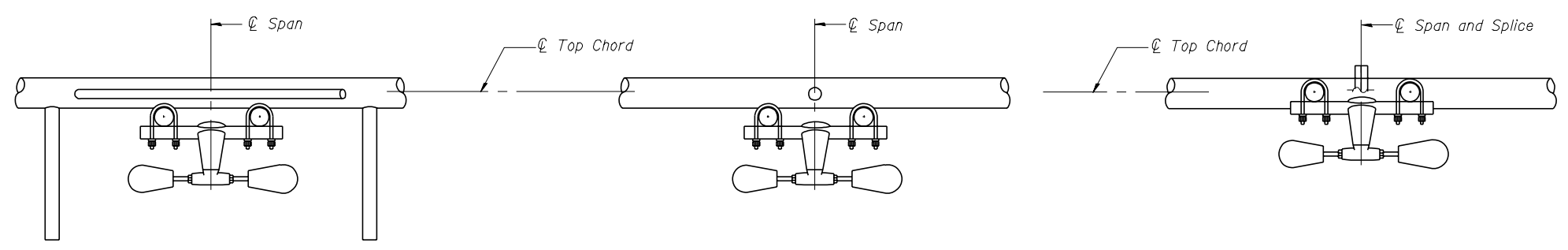

SECTION A-A

SECTION B-B

SECTION C-C

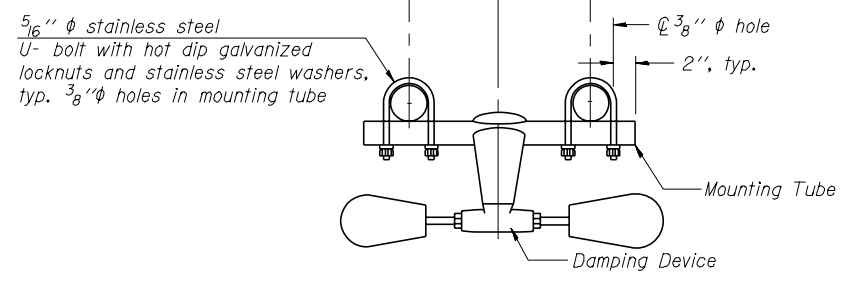

TRUSS DAMPING DEVICE CONNECTION DETAIL
 (Typical)

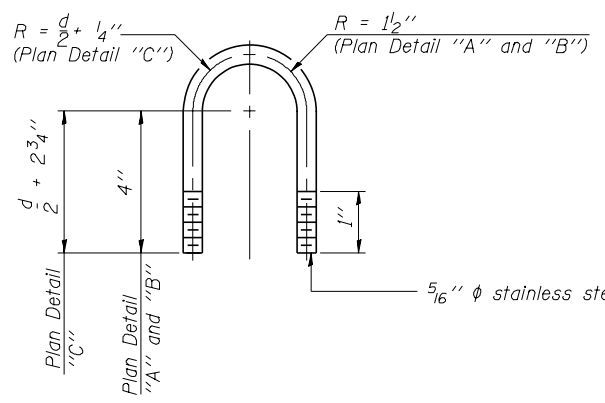

DAMPING DEVICE MOUNTING TUBE U-BOLT DETAIL
 (Typical)

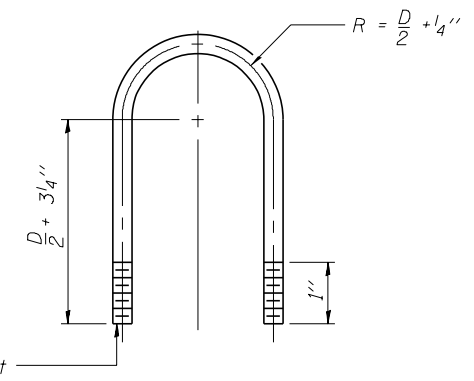

TOP CHORD TO CROSS TUBE U-BOLT DETAIL
 (Typical - Detail "A" and "B")

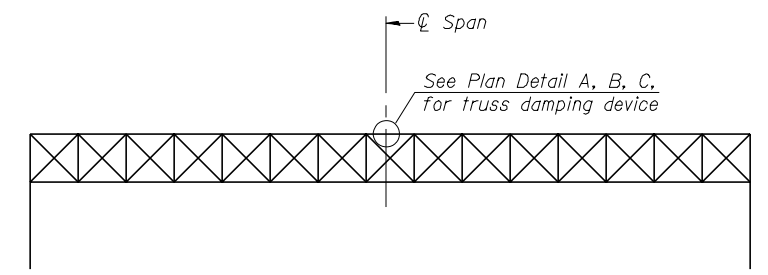

ELEVATION
 Aluminum Overhead Sign Truss

60X78_SignStructure_Sheet4.dgn

PARSONS BRINCKERHOFF

USER NAME =	lopezgonzalez	DESIGNED -	PJL	REVISED -	
		CHECKED -	AH	REVISED -	
PLDT SCALE =	N.T.S.	DRAWN -	PJL	REVISED -	
PLDT DATE =	4/27/2016	CHECKED -	JIG	REVISED -	

STATE OF ILLINOIS DEPARTMENT OF TRANSPORTATION

OVERHEAD SIGN STRUCTURE DAMPING DEVICE

SHEET NO. 0H-4 OF 0H-8 SHEETS

F.A.I. RTE.	SECTION	COUNTY	TOTAL SHEETS	SHEET NO.
90/94/290	2014-004 R&B (WB)	COOK	706	150
			CONTRACT NO. 60X78	
ILLINOIS FED. AID PROJECT				

3/4" φ stainless steel U-bolt.
Provide two washers and two hexagon locknuts. (4)
1 3/16" x 2" slots on 12" φ pipe.
(4 slots required per pipe)

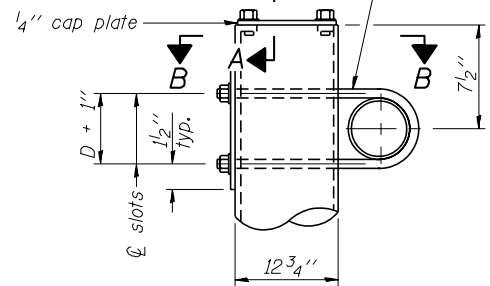

DETAIL A

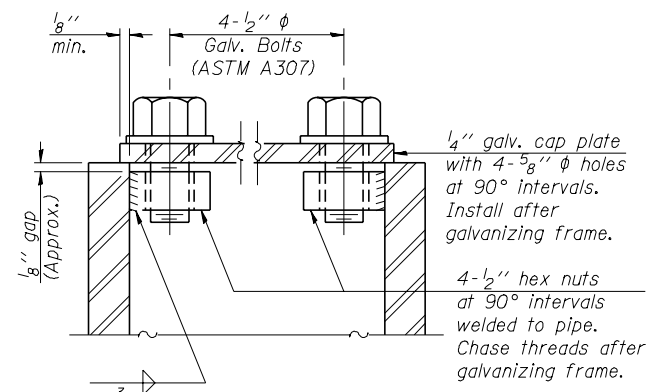

SECTION A-A

As an alternate to bolts, may use galvanized drive-fit caps installed after galvanizing frame.

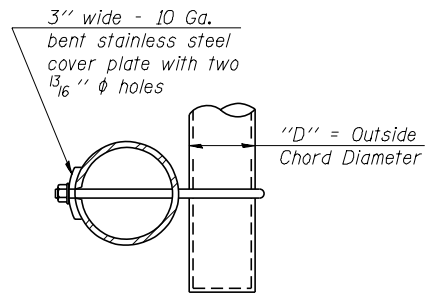

SECTION B-B

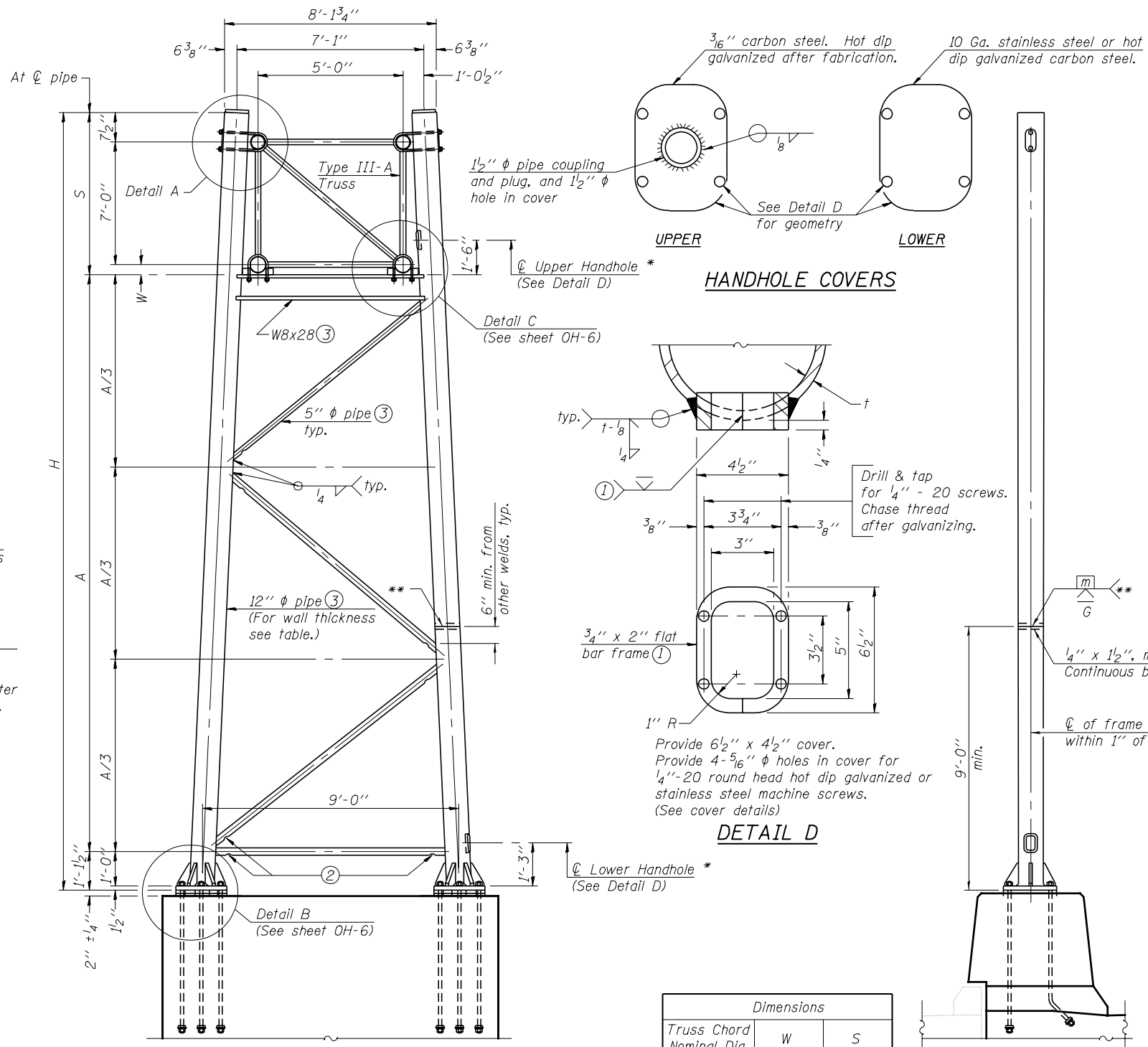

SIDE ELEVATION

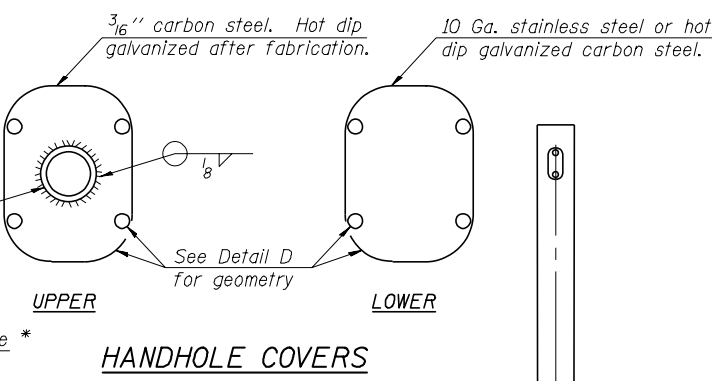

HANDHOLE COVERS

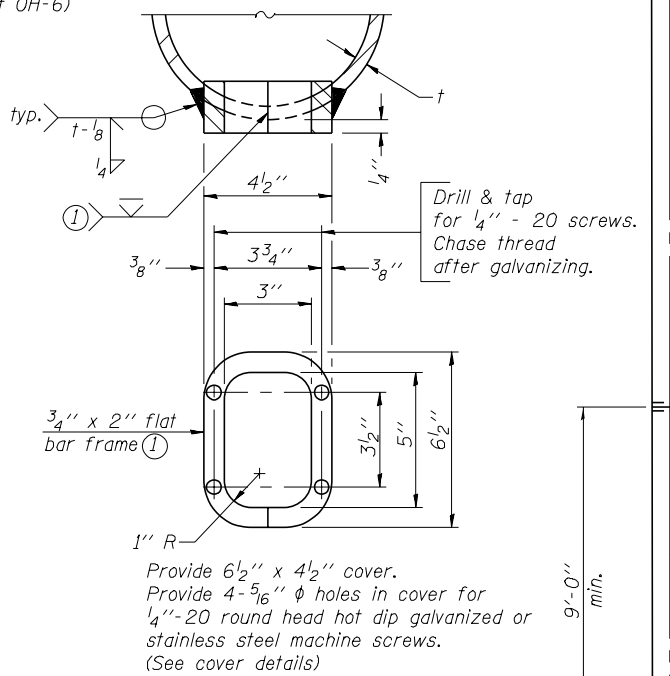

DETAIL D

Dimensions		
Truss Chord Nominal Dia.	W	S
7"	4 3/4"	8'-0 1/4"
8 1/2"	5 1/2"	8'-1"
9"	5 3/4"	8'-1 1/4"

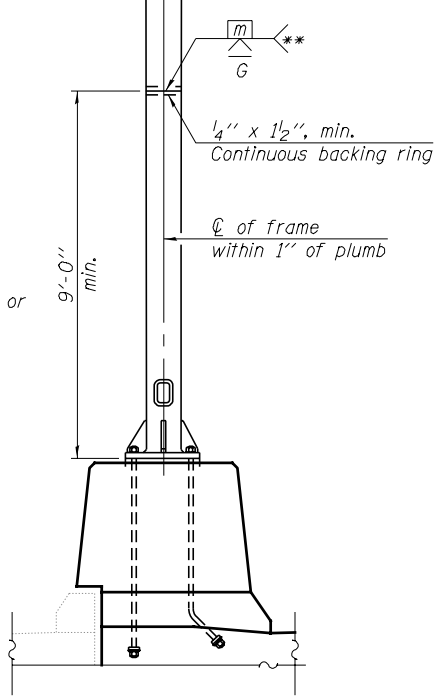

END ELEVATION

Support Design Loads: See sheet OH-1 for design and loading criteria.
Load combinations checked include deadload plus:
a) 100% wind normal to sign, 20% parallel to sign
b) 60% wind normal to sign, 30% parallel to sign

- ① In lieu of fabricated handhole frame as shown, may cut from 2" plate (rolling direction vertical). All cut faces to be ground to ANSI Roughness of 500 μin or less.
- ② Galvanizing vent holes of adequate size shall be provided on underside at each end of bracing pipes. Alternately, holes may be provided in wall of pipe column. All vent holes shall be drilled and de-burred, typ.
- ③ Steel pipe, plate, carbon steel handhole covers and rolled sections shall be hot dip galvanized after fabrication. Painting is not permitted. See sheet OH-1.
- ④ See General Notes for fasteners.
- ⑤ Dimensions shown are based on selection criteria in the Sign Structures Manual. Nonstandard applications must have dimensions verified or amended as appropriate.
- ⑥ "H" based on 15'-0" or actual sign height, whichever is greater.

* For dynamic message sign installations, provide upper and lower handholes in both legs of each support frame.

TRUSS SUPPORT DETAILS

(12" φ Pipe-Type III-A Truss)

** One butt welded joint is allowed only on one post per support frame. If used, weld procedure must be pre-approved by Engineer and joint shall receive 100% RT or UT (tension criteria) at Contractor's expense.

*** Station for interim location shown. Sign structure to be relocated in future contract (by others).

USER NAME = lopezgonzalez	DESIGNED - PJL	REVISED -
PLLOT SCALE = N.T.S.	CHECKED - AH	REVISED -
PLLOT DATE = 4/27/2016	DRAWN - PJL	REVISED -
	CHECKED - JIG	REVISED -

F.A.I. RTE.	SECTION	COUNTY	TOTAL SHEETS	SHEET NO.
90/94/290	2014-004 R&B (WB)	COOK	706	151
CONTRACT NO. 60X78				

Hexagon locknut and washer (top), leveling nut and washer (bottom). Galvanize per AASHTO M232. Nuts shall each be tightened against base plate with 200 lb.-ft. minimum torque.

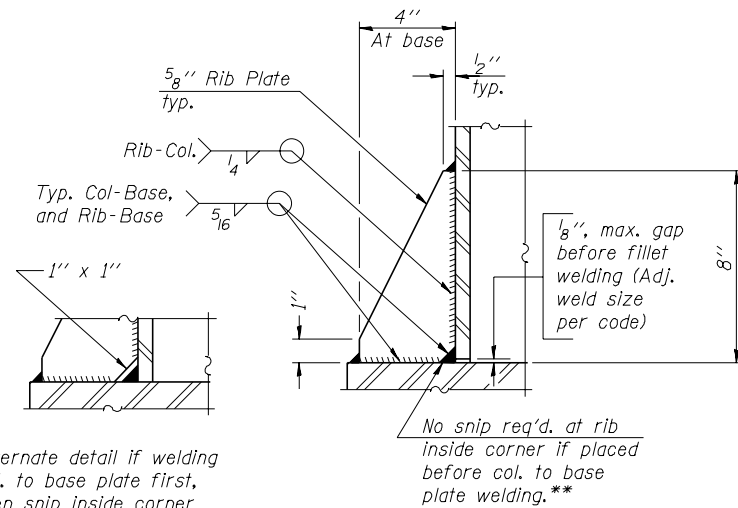
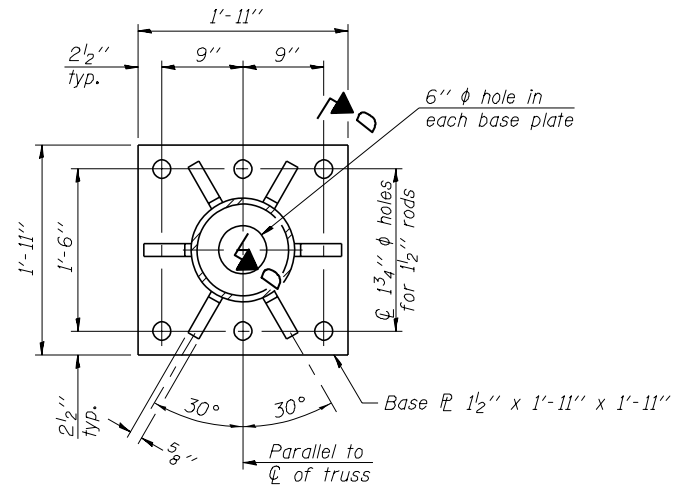
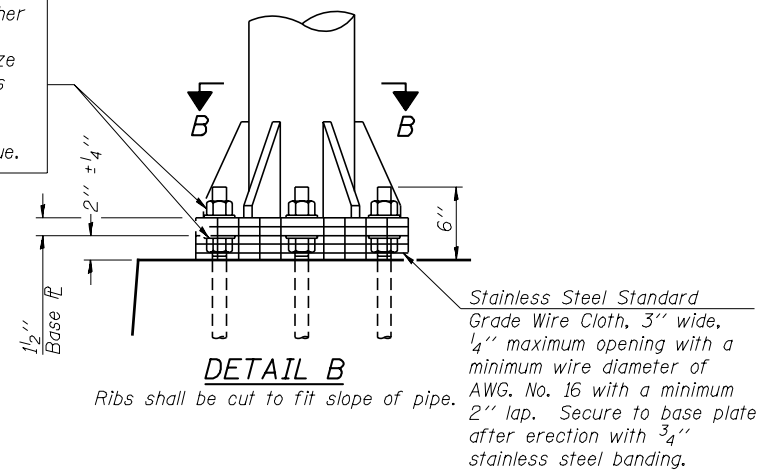

** Alternate detail if welding col. to base plate first, then snip inside corner of ribs. Terminate weld on rib 1/4" from snip.

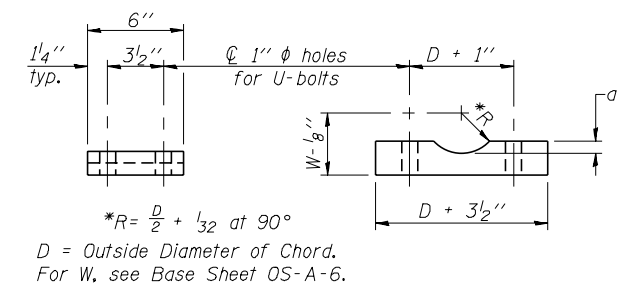
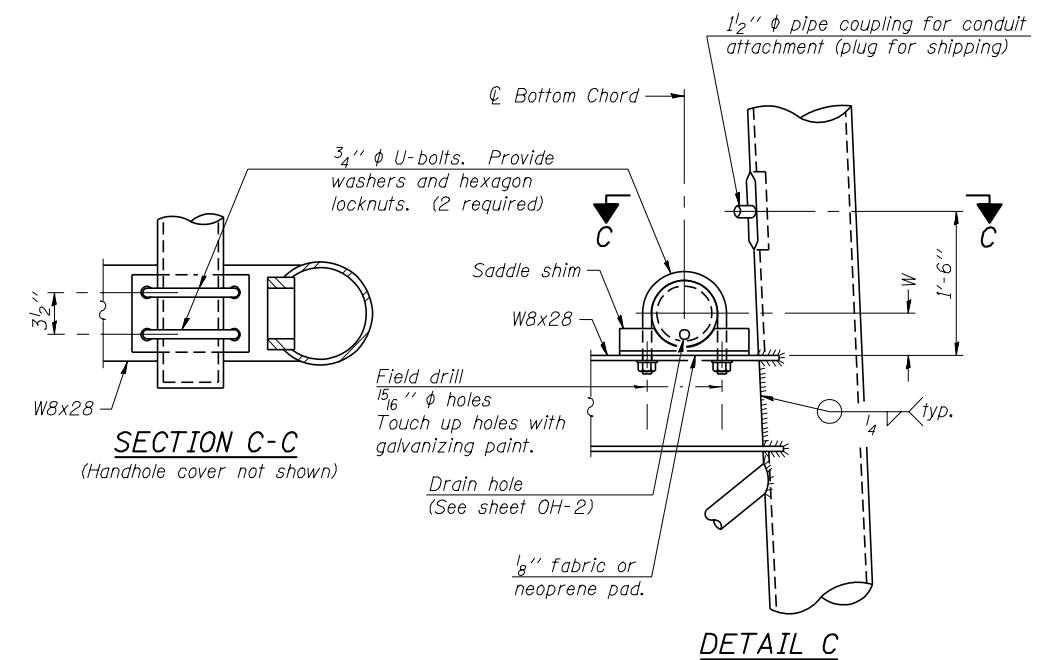

Truss Chord Nominal Dia.	a
7"	1"
8 1/2"	1 1/4"
9"	1 3/8"

SADDLE SHIM DETAIL
 ASTM B26 Alloy 356-F
 or
 ASTM B209 Alloy 6061-T651 (4 required per sign truss)

Note:
 For Anchor Rod Details and Positioning Plates, see structural plans sheet S2-57A of S2-145

TYPE III-A TRUSS
12" ϕ PIPE SUPPORT FRAME DETAILS

60X18_SignStructure_Sheet16.dgn

PARSONS BRINCKERHOFF

USER NAME = lopezgonzalez	DESIGNED - PJL	REVISED -
PLLOT SCALE = N.T.S.	CHECKED - AH	REVISED -
PLLOT DATE = 4/27/2016	DRAWN - PJL	REVISED -
	CHECKED - JIG	REVISED -

STATE OF ILLINOIS
DEPARTMENT OF TRANSPORTATION

OVERHEAD SIGN STRUCTURES
SUPPORT FRAME FOR TYPE III-A ALUMINUM TRUSS

SHEET NO. OH-6 OF OH-8 SHEETS

F.A.I. RTE.	SECTION	COUNTY	TOTAL SHEETS	SHEET NO.
90/94/290	2014-004 R&B (WB)	COOK	706	152
			CONTRACT NO. 60X78	
ILLINOIS FED. AID PROJECT				

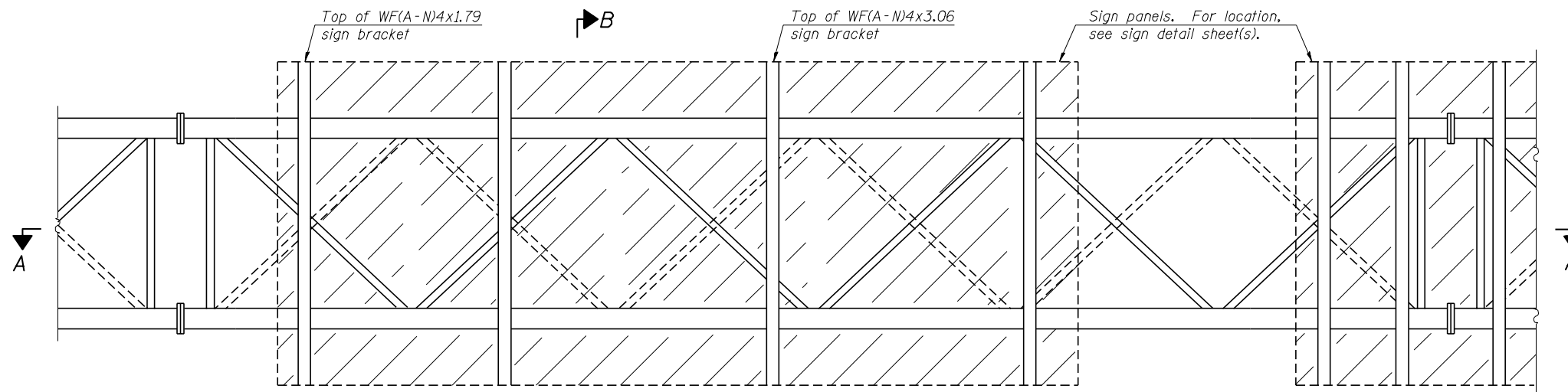

TYPICAL FRONT ELEVATION

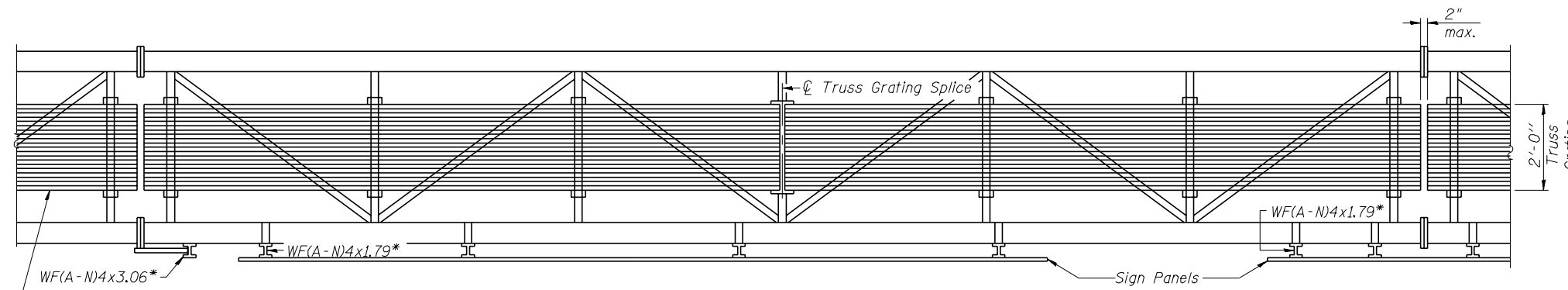

SECTION A-A

Standard Aluminum Grating, see Details T

Notes:
 For Details T, Section B-B and Grating Splice Details see sheet OH-8.
 Truss grating to facilitate inspection shall run full length (center to center of support frames) ± 12 " on overhead trusses. Cost of truss grating is included in "Overhead Sign Structure Span Type III-A".
 Truss Grating width dimensions are nominal and may vary $\pm 1/2$ " based on available standard widths.

60X78_SignStructure_SheetT.dgn

**PARSONS
BRINCKERHOFF**

USER NAME =	lopezgonzalez	DESIGNED -	PJL	REVISED -	
		CHECKED -	AEH	REVISED -	
PLLOT SCALE =	N.T.S.	DRAWN -	BOE	REVISED -	
PLLOT DATE =	4/27/2016	CHECKED -	JIG	REVISED -	

**STATE OF ILLINOIS
DEPARTMENT OF TRANSPORTATION**

**OVERHEAD SIGN STRUCTURES
ALUMINUM TRUSS GRATING DETAILS**

SHEET NO. OH-7 OF OH-8 SHEETS

F.A.I. RTE.	SECTION	COUNTY	TOTAL SHEETS	SHEET NO.
90/94/290	2014-004 R&B (WB)	COOK	706	152A
CONTRACT NO. 60X78			ILLINOIS FED. AID PROJECT	

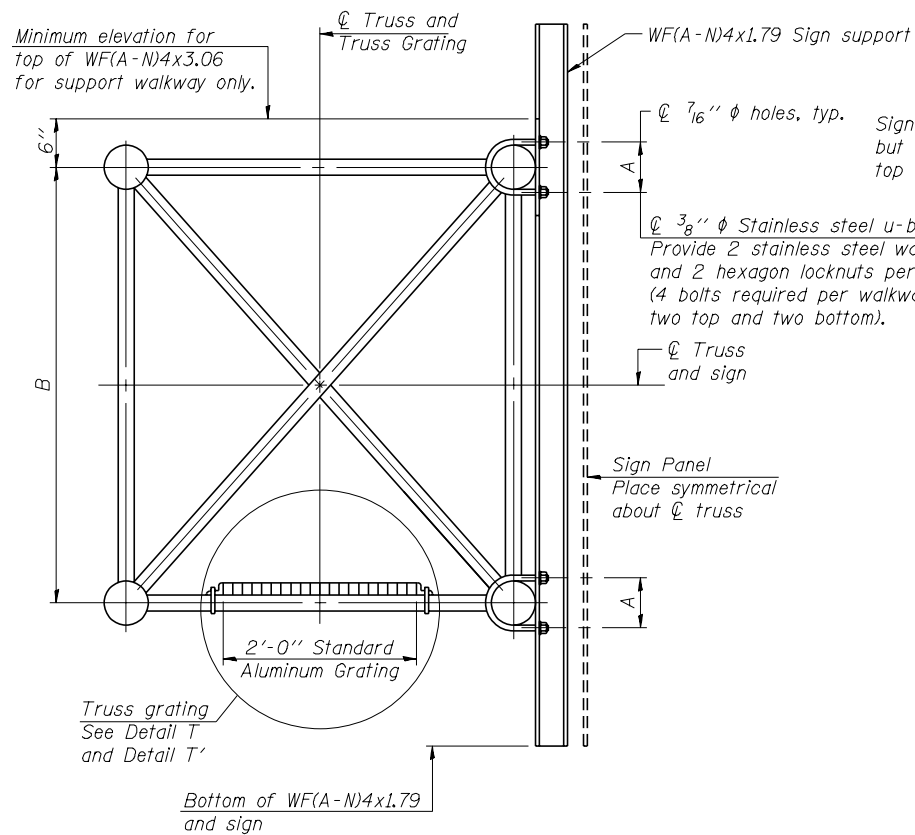

Sign shall be even with the top of the bracket, but it may extend no more than 6" above the top of the bracket for field adjustments.

Provide 2 stainless steel washers and 2 hexagon locknuts per bolt. (4 bolts required per walkway bracket, two top and two bottom).

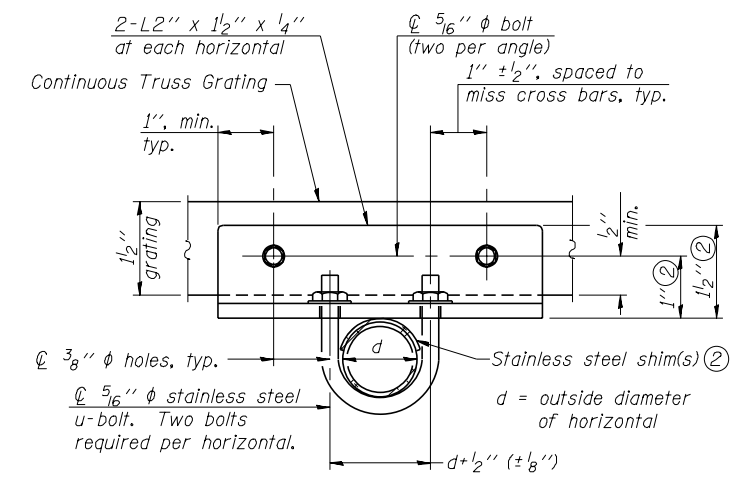
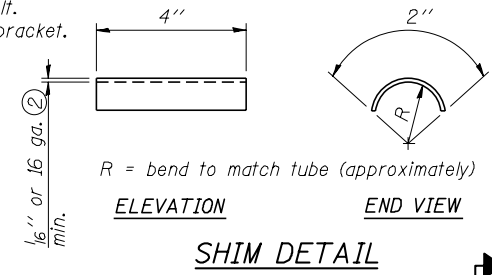

SECTION T-T

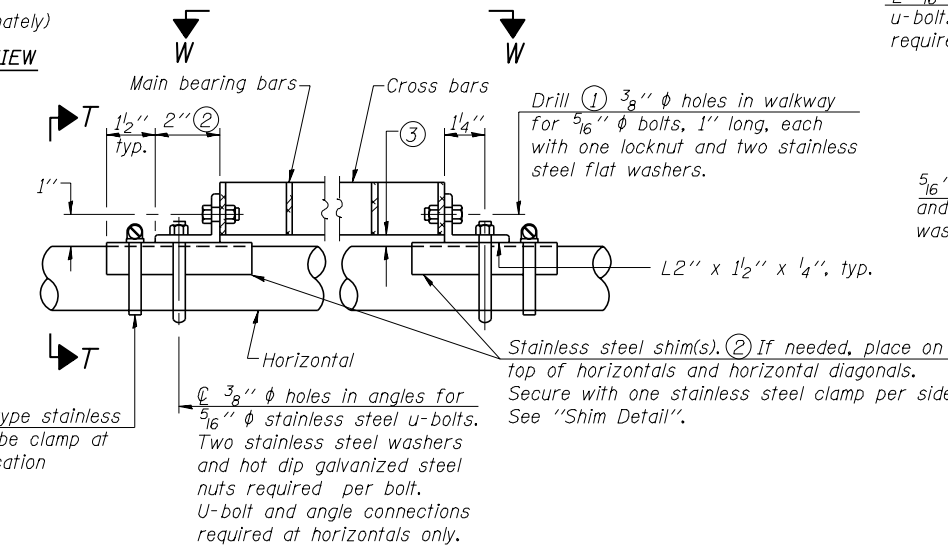

DETAIL T
(Continuous Truss grating)

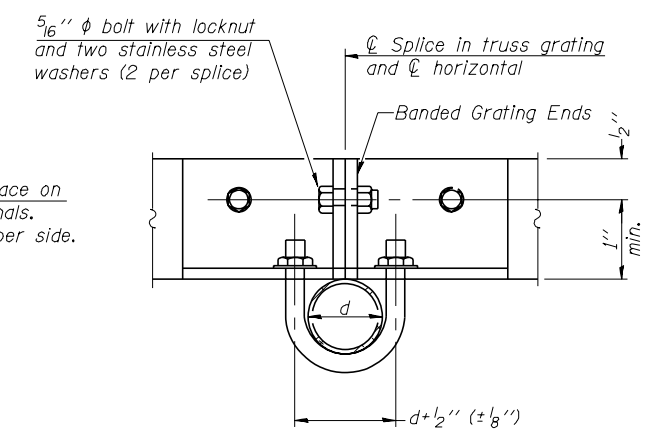

SECTION T'-T'

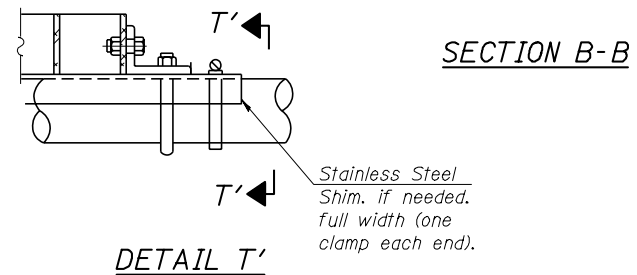

Details not shown same as Detail T. Alternate materials may be used subject to the Engineer's review and approval.

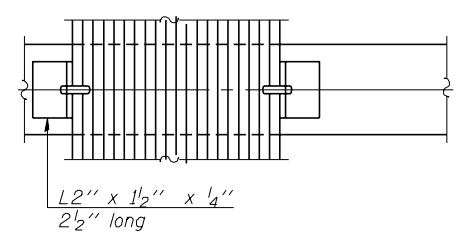
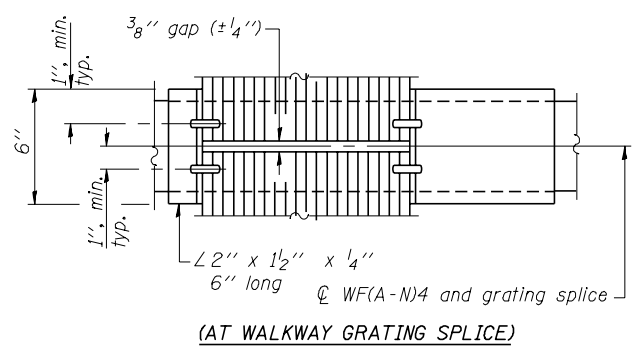

SECTION W-W

SPECIFICATIONS FOR STANDARD ALUMINUM GRATING

Main Bearing Bars shall be 3/16" x 1 1/2" on 1 3/16" centers and conform to ASTM B221 Alloy 6061-T6.
Cross bars shall be 3/16" x 1 1/2" on 4" centers and conform to ASTM B221 Alloy 6063-T5 or 6061-T6.

OR

Aluminum Grating with modified "4" sections for main bearing bars shall meet the following requirements:
Main bars shall conform to ASTM B221 Alloy 6061-T6 and have a minimum section modulus equal to 0.0705 in.³ per bar, a depth of 1 1/2", spaced on 1 3/16" centers.
Cross bars shall conform to ASTM B221 Alloy 6063-T5 or T-42 and spaced on 4" centers.

Structure Number	Station	A	B
IS0161290L000.0-002	5206+12.43 (Interim*)	8"	7'-0"

* Station for interim location shown. Sign structure to be relocated in future contract (by others).

- Drilling holes in grating may be done in shop or field, based on Contractor's preference and subject to accurate alignment.
- Stainless steel shims shall be placed as shown in Detail T if needed to compensate for alignment variations between horizontal and diagonal pipes beyond adjustment provided by angles. Thicker shims may be used subject to shims performing properly.
- Tube to grating gap may vary from 0 to 1/2", max. to align walkway, allow for camber, etc.

60X78_SignStructure_Sheet8.dgn

PARSONS BRINCKERHOFF

USER NAME = lopezgonzalez	DESIGNED - P.JL	REVISED -
PLLOT SCALE = N.T.S.	CHECKED - AEG	REVISED -
PLLOT DATE = 4/27/2016	DRAWN - BOE	REVISED -
	CHECKED - JIG	REVISED -

**STATE OF ILLINOIS
DEPARTMENT OF TRANSPORTATION**

**OVERHEAD SIGN STRUCTURES
ALUMINUM TRUSS GRATING DETAILS**

SHEET NO. 0H-8 OF 0H-8 SHEETS

F.A.I. RTE.	SECTION	COUNTY	TOTAL SHEETS	SHEET NO.
90/94/290	2014-004 R&B (WB)	COOK	706	152B
CONTRACT NO. 60X78				
ILLINOIS FED. AID PROJECT				

ELECTRICAL SYMBOLS FOR PROPOSED WORK

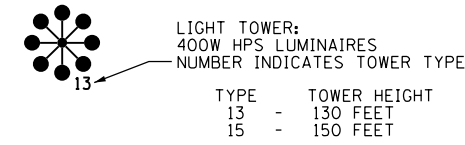

LIGHTING UNIT: TYPE AS INDICATED

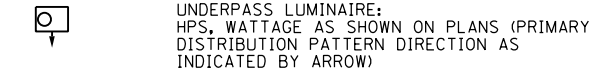
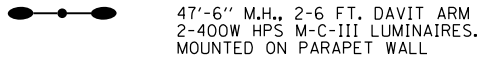
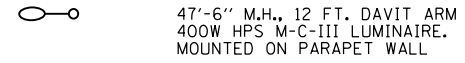
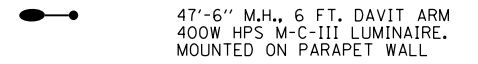

TYPE E1: PRECAST CONCRETE, 21.5"x21.5"x30", IDOT STANDARD 814001

TYPE E2: PRECAST CONCRETE-HEAVY DUTY, 22"x22"x30", IDOT STANDARD 814001

TYPE C1: COMMUNICATIONS VAULT, 49 5/8"x32 1/8"x57"

TYPE S1: PRECAST CONCRETE-HEAVY DUTY, 22"x22"x36"

TYPE S2: PRECAST CONCRETE-HEAVY DUTY SPECIAL, 30"x30"x36"

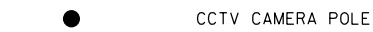
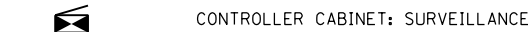
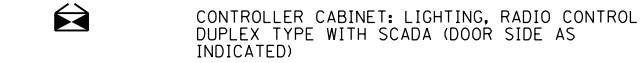
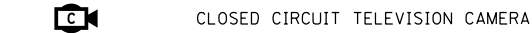
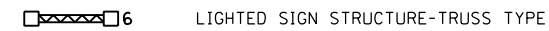
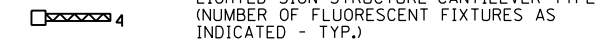
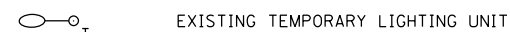
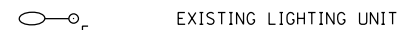
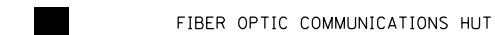
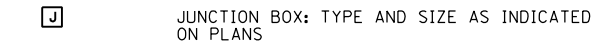

ELECTRICAL SYMBOLS FOR EXISTING CONDITIONS

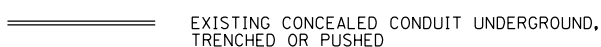
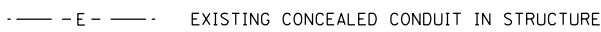
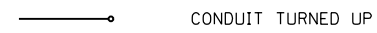
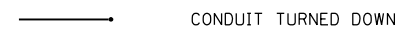
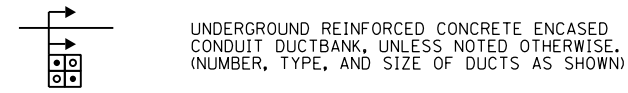
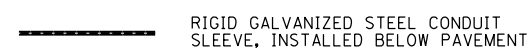
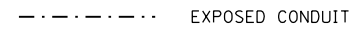
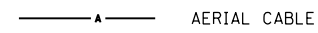
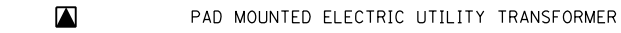
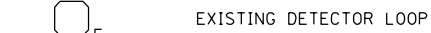
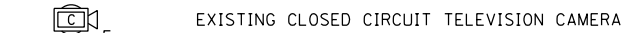
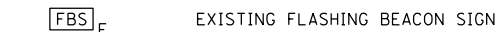
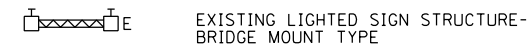
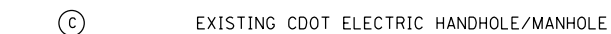

GENERAL ELECTRICAL CALLOUTS

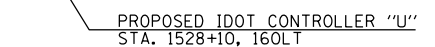
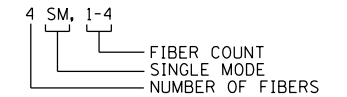
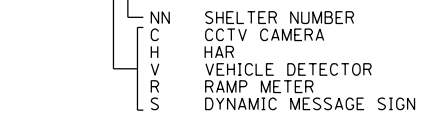
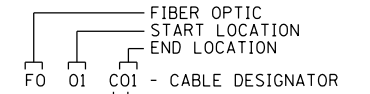
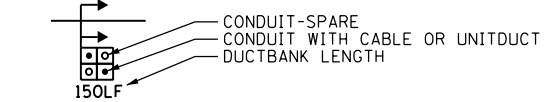
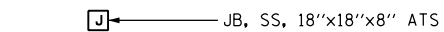
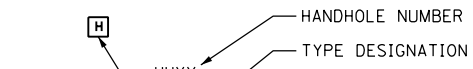
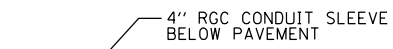
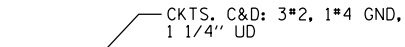
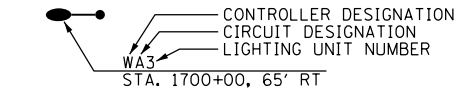
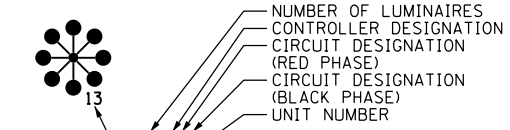

TYPICAL EXISTING TO BE REMOVED SYMBOLS



FILE PATH = p:\617479-PM\INT\pacom\line\local\AECOM\0902_NA\Documents\01_Americas\T\eng\station\60269938_Circle\Phase_11\000_CAD\016_Electrical\Sheets\60X78_Contract\0160X78-shr-Light-01



D160X78-shr-Light-01	DESIGNED - WDS	REVISED -
USER NAME = myersc	DRAWN - CAM	REVISED -
PLOT SCALE = 2,0000' / in.	CHECKED - WDS	REVISED -
PLOT DATE = 3/17/2016	DATE - 3/18/2016	REVISED -

**STATE OF ILLINOIS
DEPARTMENT OF TRANSPORTATION**

IDOT ELECTRICAL SYMBOLS

SCALE: N.T.S. SHEET 1 OF 13 SHEETS STA. TO STA.

F.A.I. RTE.	SECTION	COUNTY	TOTAL SHEETS	SHEET NO.
90/94/290	2014-004R&B	COOK	706	153
CONTRACT NO. 60X78				
ILLINOIS FED. AID PROJECT				

NOTES:

1. SEE DRAWING E-01 FOR IDOT ELECTRICAL SYMBOLS.
2. LOCATIONS OF EXISTING IDOT ELECTRICAL EQUIPMENT SHOWN ON THIS SHEET ARE APPROXIMATIONS AND MUST BE VERIFIED IN THE FIELD BY THE CONTRACTOR.
3. ALL WORK SHOWN ON THIS SHEET MUST BE COORDINATED WITH THIS CONTRACT'S CONSTRUCTION WORK AND STAGING.
4. THE EXISTING MEDIAN ROADWAY LIGHTING UNITS SHALL NOT BE REMOVED UNTIL THE TEMPORARY LIGHTING UNITS ARE INSTALLED AND OPERATIONAL.
5. PROVIDE TEMPORARY POWER FEEDS FOR LIGHTING CIRCUITS AS SHOWN. THE FINAL LOCATIONS OF THE TEMPORARY FEEDS SHALL BE COORDINATED BY THE CONTRACTOR WITH ALL STAGES OF CONSTRUCTION AND EXCAVATION WORK SO THAT THERE ARE NO CONFLICTS THAT REQUIRE THE TEMPORARY FEEDS TO BE RELOCATED DURING THE CONTRACT. ONCE THE TEMPORARY FEEDS ARE INSTALLED AND ENERGIZED THEY SHALL BE MAINTAINED FOR THE DURATION OF CONSTRUCTION UNDER THE "MAINTAIN EXISTING LIGHTING" PAY ITEM.
6. ROUTE THE TEMPORARY LIGHTING FEED INTO EXISTING HMLT ZCD1 AND MAKE THE NECESSARY CONNECTIONS TO PROVIDE POWER.
7. ROUTE THE TEMPORARY LIGHTING FEED INTO THE EXISTING JUNCTION BOXES ATTACHED TO STRUCTURE AND MAKE THE NECESSARY CONNECTIONS TO PROVIDE POWER TO THE EXISTING UNDERPASS LIGHTING.
8. REMOVE TEMPORARY LIGHTING UNITS FA6 AND FC6 AT THE END OF THE PROJECT AND REPLACE THE TEMPORARY AERIAL FEED TO PERMANENT LIGHTING UNIT FE4 AS SHOWN ON DRAWING E-05.
9. REMOVE EXISTING CABLES FROM EXISTING CONDUIT AND CLEAN CONDUIT FOR RE-USE. SEE DRAWING E-04 FOR LOCATIONS WHERE NEW CABLES WILL BE INSTALLED IN EXISTING CONDUIT.
10. TEMPORARY AERIAL CABLES TO BE REMOVED AND DISPOSED OF AFTER THE PERMANENT LIGHTING CIRCUITS HAVE BEEN INSTALLED.
11. THE TEMPORARY LIGHTING UNITS ALONG THE NORTH SIDE OF THE CONGRESS VIADUCT SHALL INITIALLY BE FED FROM LIGHTING CIRCUITS A, B AND C BUT WILL BE TRANSFERRED TO LIGHTING CIRCUITS D, E AND F DURING THE LATER STAGES OF THE PROJECT.

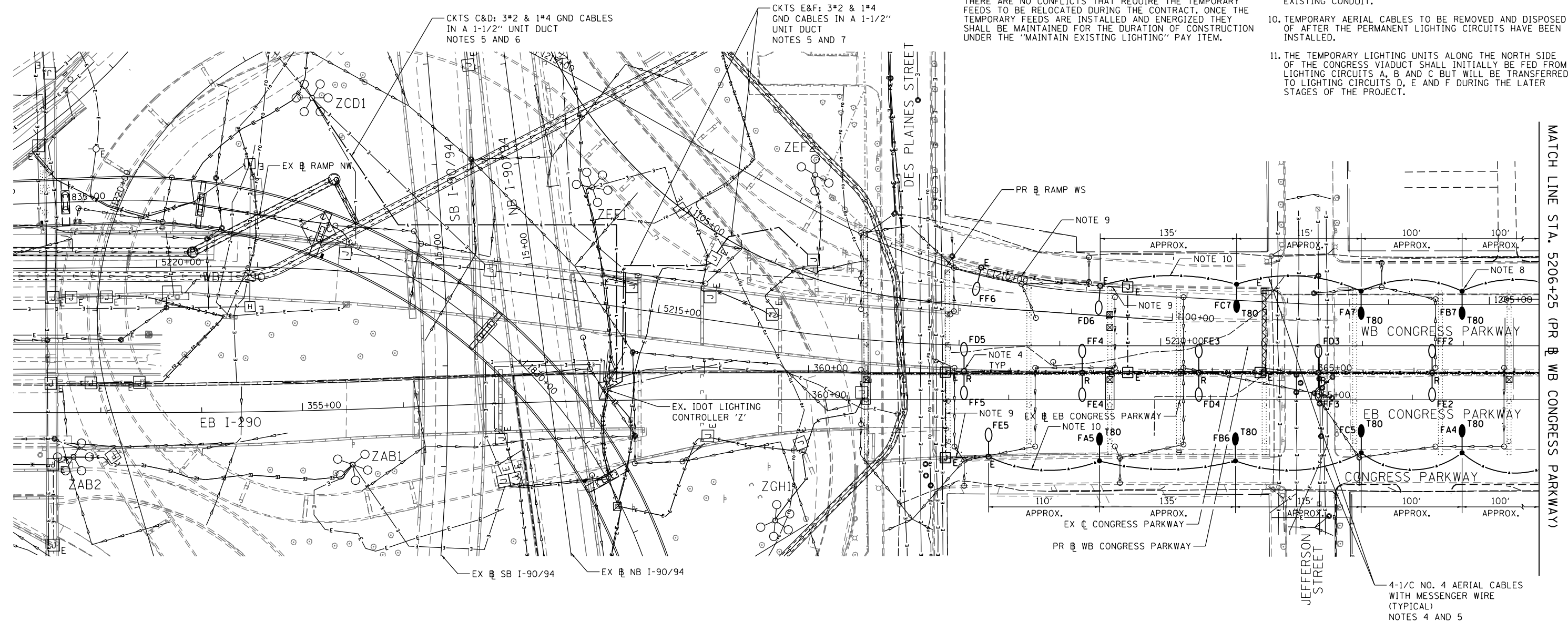

MATCH LINE STA. 5206+25 (PR WB CONGRESS PARKWAY)

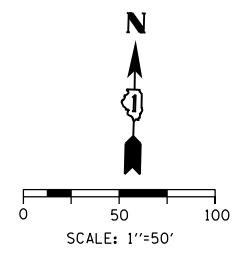

E-02

FILE PATH = p:\617479-PM\INT\rescom\line\local\AECOM\0502_NA\Documents\01_Americas\T_engor\station\60269938_Circle\Phase_11\000_CAD\016_Electrical\Sheets\60X78_Contract\0160X78-sh-Light-02



D160X78-sh-Light-02	DESIGNED - WDS	REVISED -
USER NAME = myersc	DRAWN - CAM	REVISED -
PLOT SCALE = 100.0000' / in.	CHECKED - WDS	REVISED -
PLOT DATE = 3/17/2016	DATE - 3/18/2016	REVISED -

**STATE OF ILLINOIS
DEPARTMENT OF TRANSPORTATION**

EXISTING/TEMPORARY LIGHTING PLAN	
WB I-290 OVER I-90/94 AND WB CONGRESS PARKWAY	
SCALE: 1"=50'	SHEET 2 OF 13 SHEETS
STA. 5206+25	TO STA. 5221+50

F.A.I. RTE.	SECTION	COUNTY	TOTAL SHEETS	SHEET NO.
90/94/290	2014-004R&B	COOK	706	154
CONTRACT NO. 60X78				
ILLINOIS FED. AID PROJECT				

NOTES:

1. SEE DRAWING E-01 FOR IDOT ELECTRICAL SYMBOLS.
2. LOCATIONS OF EXISTING IDOT ELECTRICAL EQUIPMENT SHOWN ON THIS SHEET ARE APPROXIMATIONS AND MUST BE VERIFIED IN THE FIELD BY THE CONTRACTOR.
3. ALL WORK SHOWN ON THIS SHEET MUST BE COORDINATED WITH THIS CONTRACT'S CONSTRUCTION WORK AND STAGING.
4. EXISTING LIGHTING UNIT TO BE DISCONNECTED, REMOVED AND SALVAGED TO IDOT. THE CONTRACTOR SHALL TAKE CARE NOT TO DAMAGE THE EXISTING ANCHOR BOLTS AND FOUNDATION DURING THE LIGHTING UNIT REMOVAL PROCESS. IF THE FOUNDATIONS AND/OR ANCHOR BOLTS ARE DAMAGED DURING THE REMOVAL WORK SUCH THAT THE NEW DAVIT POLE CANNOT BE INSTALLED PROPERLY, THE EXISTING SECTION OF WALL CONTAINING THE LIGHT POLE FOUNDATION SHALL BE RECONSTRUCTED. SEE THE STRUCTURAL PLANS FOR THE FOUNDATION DETAILS. SEE NOTE 13.
5. THE EXISTING MEDIAN ROADWAY LIGHTING UNITS SHALL NOT BE REMOVED UNTIL THE TEMPORARY LIGHTING UNITS ARE INSTALLED AND OPERATIONAL.
6. PROVIDE TEMPORARY POWER FEEDS FOR LIGHTING CIRCUITS AS SHOWN. THE FINAL LOCATIONS OF THE TEMPORARY FEEDS SHALL BE COORDINATED BY THE CONTRACTOR WITH ALL STAGES OF CONSTRUCTION AND EXCAVATION WORK SO THAT THERE ARE NO CONFLICTS THAT REQUIRE THE TEMPORARY FEEDS TO BE RELOCATED DURING THE CONTRACT. ONCE THE TEMPORARY FEEDS ARE INSTALLED AND ENERGIZED THEY SHALL BE MAINTAINED FOR THE DURATION OF CONSTRUCTION UNDER THE "MAINTAIN EXISTING LIGHTING" PAY ITEM.
7. CONNECT THE TEMPORARY AERIAL CABLES TO THE LIGHTING CIRCUITS A, B AND C LOCATED WITHIN THE EXISTING LIGHTING UNIT FB2/FC2 & FA3/FB4 RESPECTIVELY.
8. PRIOR TO REPLACING THE EXISTING LIGHTING UNIT, THE EXISTING LIGHTING CIRCUIT CABLES SHALL BE PULLED BACK TO THE NEAREST ADJACENT JUNCTION BOX AND COILED FOR RE-USE. THE WORK TO PULL BACK THE EXISTING CABLES FOR RE-USE SHALL BE PAID FOR UNDER THE "REMOVAL OF LIGHTING UNIT, SALVAGE" PAY ITEM.
9. REMOVE EXISTING CABLES FROM CONDUIT BETWEEN LIGHTING UNITS FB1/FC1 AND FB2/FC2 WHEN THE EXISTING LIGHTING UNITS ARE REPLACED.
10. THE TEMPORARY LIGHTING UNITS MUST BE KEPT OPERATIONAL DURING NIGHTTIME HOURS FOR ALL STAGES OF CONSTRUCTION. THE CONTRACTOR MUST PROVIDE ALL TEMPORARY POWER FEEDS REQUIRED TO KEEP THE TEMPORARY LIGHTING UNITS FUNCTIONAL DURING THE REMOVAL AND REPLACEMENT OF EXISTING LIGHTING UNITS FA1, FB1, FC1, FB2 AND FC2 EVEN IF NOT SHOWN ON THE PLANS. ALL TEMPORARY POWER FEED WORK REQUIRED BUT NOT SHOWN ON THE PLANS WILL NOT BE PAID FOR SEPARATELY AND WILL BE INCLUDED IN THE COST OF THE "MAINTAINING EXISTING LIGHTING SYSTEM" PAY ITEM.
11. REMOVE TEMPORARY LIGHTING UNITS FA6 AND FC6 AT THE END OF THE PROJECT AND REPLACE THE TEMPORARY AERIAL FEED TO PERMANENT LIGHTING UNIT FE4 AS SHOWN ON DRAWING E-05. THIS WORK SHALL BE PAID FOR UNDER THE "REMOVAL OF TEMPORARY LIGHTING UNIT" PAY ITEM.
12. REMOVE AND DISPOSE OF EXISTING HOMERUN CABLES: FOR LIGHTING CIRCUITS D, E & F IN THE EXISTING CONDUIT TO REMAIN FROM IDOT LIGHTING CONTROLLER 'F' TO EXISTING LIGHTING UNIT FD1 & FF1. THE EXISTING CONDUIT TO REMAIN SHALL BE RODDED AND CLEANED PRIOR TO INSTALLING NEW CABLES.
13. THE EXISTING LIGHTING UNIT SHALL NOT BE REMOVED UNTIL THE PERMANENT MEDIAN LIGHTING CIRCUITS D, E AND F ARE INSTALLED, ENERGIZED AND READY TO BE CONNECTED TO THE TEMPORARY LIGHTING UNITS.
14. THE TEMPORARY LIGHTING UNITS ALONG THE NORTH SIDE OF THE CONGRESS VIADUCT SHALL INITIALLY BE FED FROM LIGHTING CIRCUITS A, B AND C BUT WILL BE TRANSFERRED TO LIGHTING CIRCUITS D, E AND F DURING THE LATER STAGES OF THE PROJECT. SEE NOTES 4 AND 13.

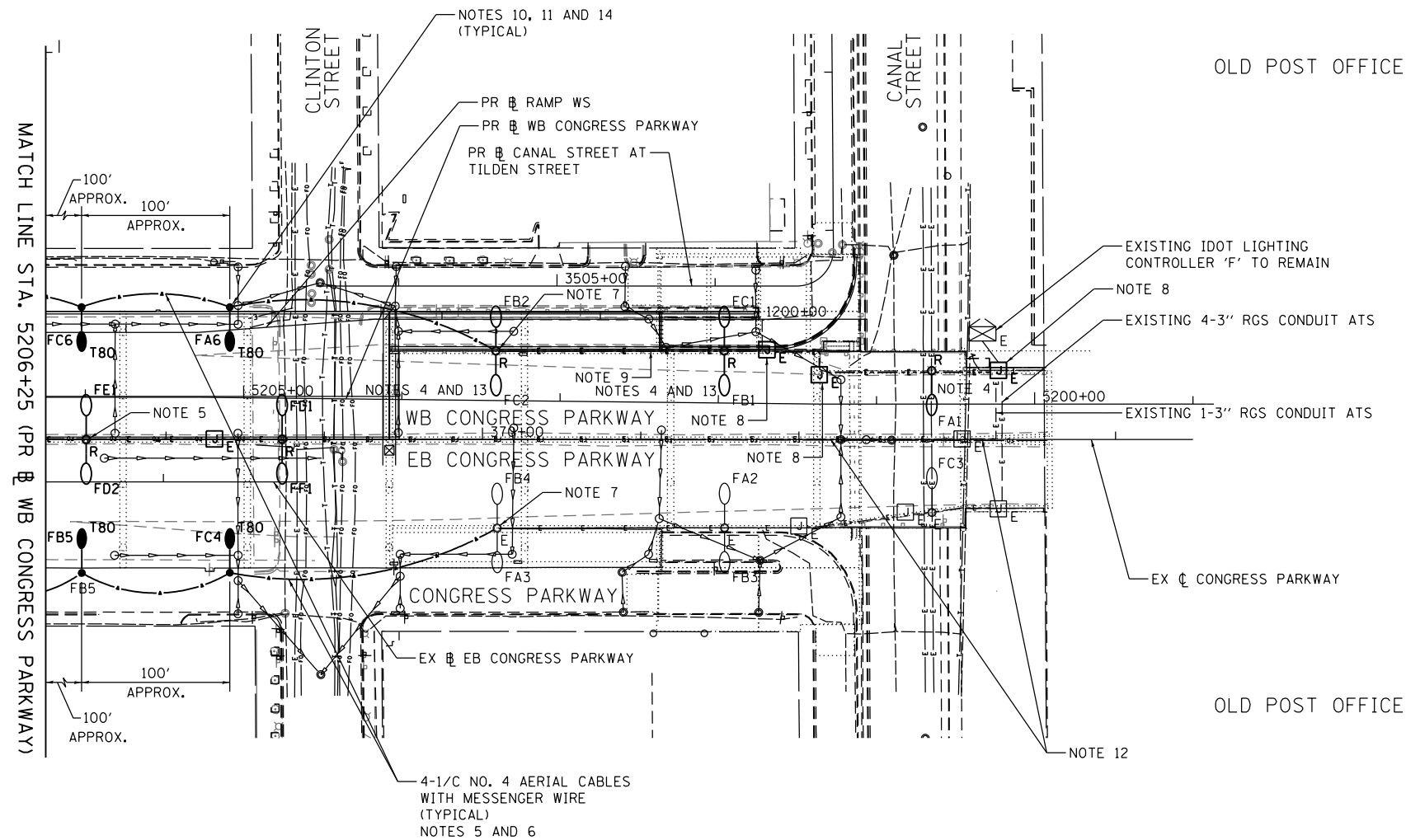

FILE PATH = p:\617479-PM\INT\rescomon\line\local\AE\CDM_0502_NA\Documents\01_Americas\T\engor\station\60269938_Circle\Phase_11\000_CAD\016_Electrical\Sheets\60X78_Contract\0160X78-shr-Light-03



D160X78-shr-Light-03
 USER NAME = myersc
 PLOT SCALE = 100.0000' / in.
 PLOT DATE = 3/17/2016

DESIGNED - WDS	REVISED -
DRAWN - CAM	REVISED -
CHECKED - WDS	REVISED -
DATE - 3/18/2016	REVISED -

STATE OF ILLINOIS
 DEPARTMENT OF TRANSPORTATION

EXISTING/TEMPORARY LIGHTING PLAN
 WB I-290 OVER I-90/94 AND WB CONGRESS PARKWAY
 SCALE: 1"=50' SHEET 3 OF 13 SHEETS STA. 5199+00 TO STA. 5206+25

F.A.I. RTE.	SECTION	COUNTY	TOTAL SHEETS	SHEET NO.
90/94/290	2014-004R&B	COOK	706	155
CONTRACT NO. 60X78				
ILLINOIS FED. AID PROJECT				

FILE PATH = p:\1617479-PMINT\rescom\line\local\AECDM_0502_04\016_Electrical\Sheets\60X78_Contract\0160X78-shr-Light-04

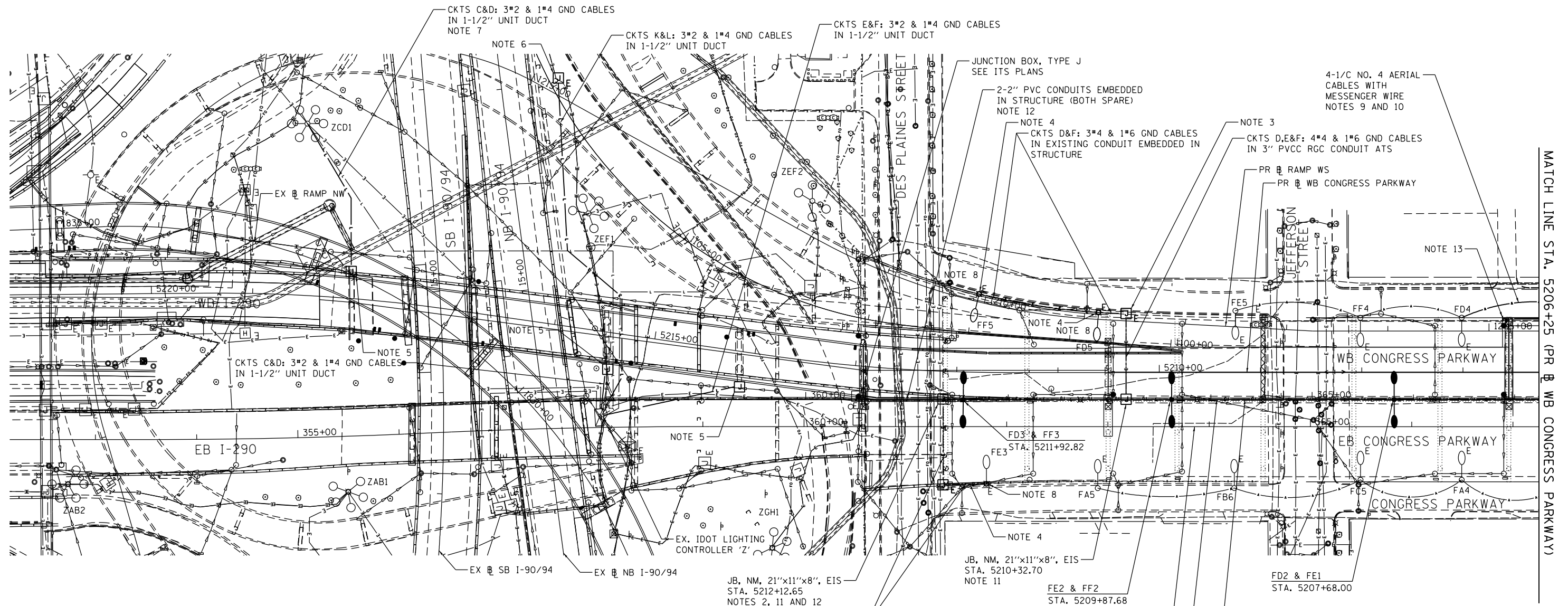

NOTES:

1. SEE DRAWING E-01 FOR IDOT ELECTRICAL SYMBOLS.
2. INTERCEPT EXISTING CONDUIT ATTACHED TO STRUCTURE AND CONNECT TO NEW CONDUIT ATTACHED TO STRUCTURE. ROUTE NEW CONDUIT TO EMBEDDED JUNCTION BOX. ROUTE NEW LIGHTING CIRCUIT CABLES FROM NEW LIGHTING UNIT (FD3/FF3) TO EXISTING LIGHTING UNIT (FE3) IN THE NEW AND EXISTING CONDUITS.
3. ROUTE NEW CONDUIT ATTACHED TO STRUCTURE TO EXISTING EMBEDDED JUNCTION BOX.
4. ROUTE NEW CABLES IN EXISTING CONDUIT TO REFEED THE EXISTING LIGHTING UNITS TO REMAIN, RE-CIRCUIT AS SHOWN. PROVIDE NEW CIRCUIT LABELS ON EXISTING LIGHT POLES AS REQUIRED.
5. SEE DRAWING E-06 FOR CONTINUATION OF THE LIGHTING CIRCUITS FOR THE UNDERPASS LIGHTING SYSTEM.
6. ROUTE NEW LIGHTING CABLES TO EXISTING JUNCTION BOX ATTACHED TO STRUCTURE AND CONNECT TO EXISTING LIGHTING CIRCUIT CABLES LOCATED WITHIN THE BOX.
7. ROUTE NEW LIGHTING CABLES INTO BASE OF EXISTING HMLT ZCD1 AND MAKE THE NECESSARY CONNECTIONS.
8. REMOVE AND REPLACE THE EXISTING LIGHT POLE DECALS WITH NEW.
9. REFEED THE TEMPORARY LIGHTING UNITS TO REMAIN FROM PERMANENT LIGHTING UNIT FE4.
10. THE TEMPORARY LIGHTING UNITS TO REMAIN AT THE END OF THE CONTRACT ALONG THE NORTH SIDE SHALL BE FED FROM LIGHTING CIRCUITS D, E AND F AS SHOWN. AFTER THE PERMANENT MEDIAN LIGHTING CIRCUITS HAVE BEEN INSTALLED.
11. EMBEDDED JUNCTION BOX LOCATIONS ARE APPROXIMATIONS. CONTRACTOR SHALL COORDINATE FINAL INSTALLATION LOCATION OF JUNCTION BOXES WITH STRUCTURAL WORK.
12. PROVIDE TWO 2-INCH PVC CONDUITS EMBEDDED IN SOUTH PARAPET WALL OF STRUCTURE NO. 016-1703 BETWEEN THE ITS JUNCTION BOX AND THE LIGHTING JUNCTION BOX.
13. PROVIDE A 2 INCH PVC CONDUIT EMBEDDED IN THE NEW PARAPET WALL TO THE LIMITS OF THE NEW WALL CONSTRUCTION AND CAP CONDUIT FOR FUTURE USE. SEE STRUCTURAL PLANS FOR THE END LIMITS OF THE NEW WALL.

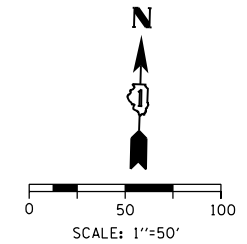

E-04



D160X78-shr-Light-04	DESIGNED - WDS	REVISED -
USER NAME = myersc	DRAWN - CAM	REVISED -
PLOT SCALE = 100.0000' / 1"	CHECKED - WDS	REVISED -
PLOT DATE = 3/17/2016	DATE - 3/18/2016	REVISED -

**STATE OF ILLINOIS
DEPARTMENT OF TRANSPORTATION**

PROPOSED LIGHTING PLAN WB I-290 OVER I-90/94 AND WB CONGRESS PARKWAY			
SCALE: 1"=50'	SHEET 4 OF 13 SHEETS	STA.5206+25 TO STA.5221+50	

F.A.I. RTE.	SECTION	COUNTY	TOTAL SHEETS	SHEET NO.
90/94/290	2014-004R&B	COOK	706	156
CONTRACT NO. 60X78				
ILLINOIS FED. AID PROJECT				

NOTES:

- SEE DRAWING E-01 FOR IDOT ELECTRICAL SYMBOLS.
- INSTALL A NEW DAVIT ARM LIGHTING UNIT ON THE EXISTING PARAPET WALL FOUNDATION. IF THE EXISTING ANCHOR BOLTS ARE DAMAGED DURING THE EXISTING LIGHT POLE REMOVAL WORK, THE CONTRACTOR SHALL RECONSTRUCT THE EXISTING FOUNDATION IN THE EXISTING PARAPET WALL. SEE STRUCTURAL PLANS FOR THE NEW FOUNDATION DETAILS.
- PULL THE EXISTING LIGHTING CIRCUIT CABLES BACK THROUGH THE EXISTING CONDUITS AND JUNCTION BOXES TO THE NEW LIGHTING UNITS AND MAKE THE NECESSARY CONNECTIONS TO REFEED THE UNITS.
- ROUTE A 3 INCH PVC COATED RIGID GALVANIZED STEEL CONDUIT OUT OF THE BOTTOM OF THE JUNCTION BOX THROUGH THE DECK AND CONNECT TO CONDUIT ATTACHED TO STRUCTURE.
- REFEED THE TEMPORARY LIGHTING UNITS TO REMAIN FROM PERMANENT LIGHTING UNIT FE4 AS SHOWN.
- ROUTE NEW LIGHTING CABLES IN EXISTING CONDUIT FROM IDOT LIGHTING CONTROLLER 'F' TO THE NEW EMBEDDED JUNCTION BOX IN THE WB CONGRESS PARKWAY MEDIAN WALL.
- INTERCEPT THE EXISTING CONDUIT EMBEDDED IN THE MEDIAN PARAPET WALL TO REMAIN. PROVIDE ALL REQUIRED CONDUIT AND FITTINGS TO CONNECT THE CONDUIT RUN TO THE NEW EMBEDDED JUNCTION BOX AS SHOWN. SEE STRUCTURE PLANS FOR LIMIT OF EXISTING WALL REMOVAL.
- THE TEMPORARY LIGHTING UNITS TO REMAIN AT THE END OF THE CONTRACT ALONG THE NORTH SIDE SHALL BE FED FROM LIGHTING CIRCUITS D, E AND F AS SHOWN AFTER THE PERMANENT MEDIAN LIGHTING CIRCUITS HAVE BEEN INSTALLED.
- EMBEDDED JUNCTION BOX LOCATIONS ARE APPROXIMATIONS. CONTRACTOR SHALL COORDINATE FINAL INSTALLATION LOCATION OF JUNCTION BOXES WITH STRUCTURAL WORK.

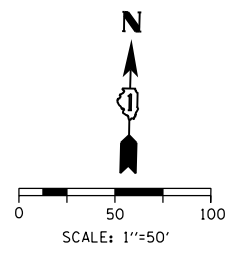
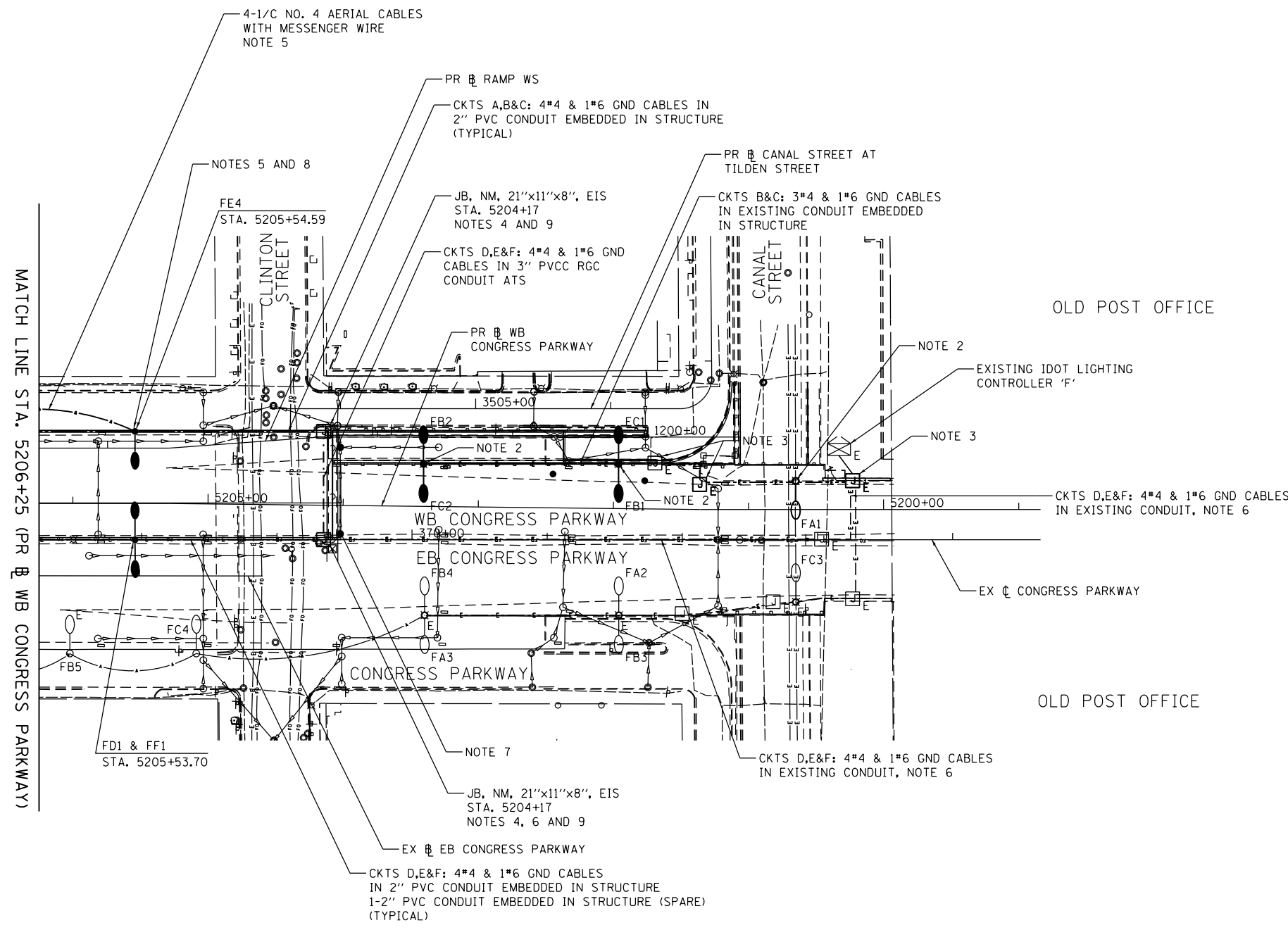

E-05

FILE PATH = p:\6179-PMINT\pcomon\line\local\AECOM\0502_NA\Documents\01_Americas\T\engp\station\60269338_Circle\Phase_11\000_CAD\016_Electrical\Sheets\60X78_Contract\0160X78-shr-Light-05



D160X78-shr-Light-05
 USER NAME = myersc
 PLOT SCALE = 100.0000' / in.
 PLOT DATE = 3/17/2016

DESIGNED - WDS	REVISED -
DRAWN - CAM	REVISED -
CHECKED - WDS	REVISED -
DATE - 3/18/2016	REVISED -

**STATE OF ILLINOIS
 DEPARTMENT OF TRANSPORTATION**

PROPOSED LIGHTING PLAN
WB I-290 OVER I-90/94 AND WB CONGRESS PARKWAY
 SCALE: 1"=50' SHEET 5 OF 13 SHEETS STA. 5199+00 TO STA. 5206+25

F.A.I. RTE.	SECTION	COUNTY	TOTAL SHEETS	SHEET NO.
90/94/290	2014-004R&B	COOK	706	157
CONTRACT NO. 60X78				
ILLINOIS FED. AID PROJECT				

UNDERPASS LUMINAIRE TABLE		
LUMINAIRE	STATION & OFFSET (# WB I-290)	NOTES
C1	STA. 5216+70.5, 13.5 RT	NOTES 9 & 10
D1	STA. 5216+03.3, 25.5 LT	NOTES 9 & 10
C2	STA. 5215+97.0, 6.0 LT	NOTES 9 & 10
D2	STA. 5216+64.3, 6.0 LT	NOTES 9 & 10
C3	STA. 5216+57.9, 25.5 LT	NOTES 9 & 10
D3	STA. 5215+90.6, 25.5 LT	NOTES 9 & 10
C4	STA. 5217+53.0, 13.5 RT.	NOTES 9 & 10
D4	STA. 5216+92.3, 13.5 RT	NOTES 9 & 10
C5	STA. 5216+88.3, 6.0 LT	NOTES 9 & 10
D5	STA. 5217+49.6, 6.0 LT	NOTES 9 & 10
C6	STA. 5217+46.3, 25.5 LT	NOTES 9 & 10
D6	STA. 5216+84.5, 25.5 LT	NOTES 9 & 10

NOTE: CENTERING THE UNDERPASS LUMINAIRES BETWEEN THE STRUCTURAL BEAMS TAKES PRECEDENCE OVER THE STATION AND OFFSET PROVIDED IN THE TABLE.

EXISTING UNDERPASS LIGHTING PLAN

NOTE 2

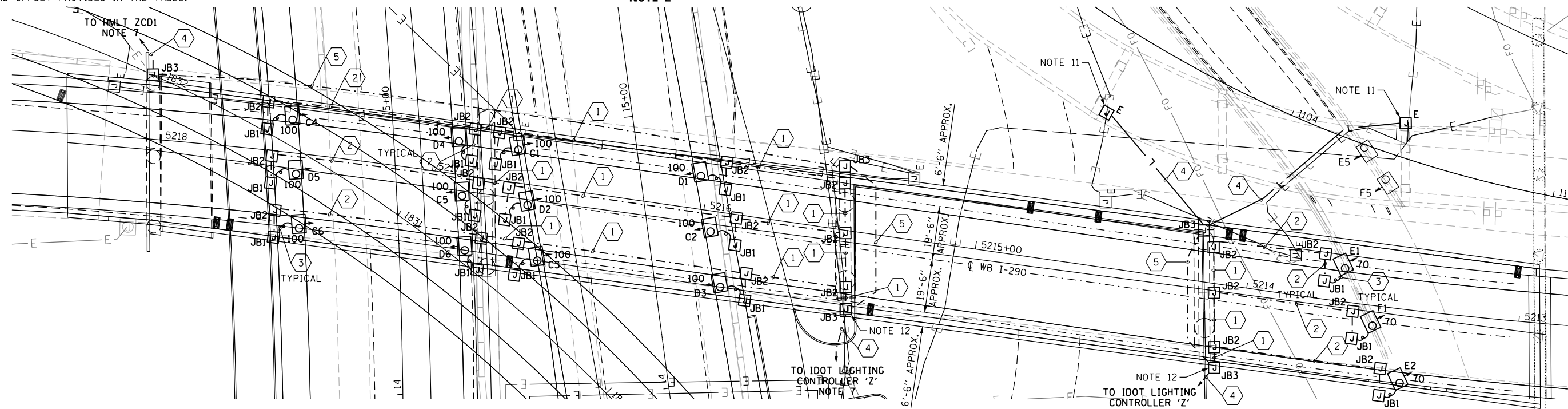

NOTES:

- SEE DRAWING E-01 FOR IDOT ELECTRICAL SYMBOLS AND ABBREVIATIONS.
- LOCATIONS OF EXISTING ELECTRICAL EQUIPMENT SHOWN ON THIS DRAWING ARE APPROXIMATIONS AND MUST BE VERIFIED IN THE FIELD BY THE CONTRACTOR.
- THE REMOVAL OF EXISTING UNDERPASS LUMINAIRES MUST INCLUDE THE REMOVAL OF ALL CABLES, CONDUIT, JUNCTION BOXES, AND HARDWARE ASSOCIATED WITH THE EXISTING UNDERPASS LIGHTING. COST FOR THIS WORK WILL NOT BE PAID FOR SEPARATELY BUT WILL BE INCLUDED AS PART OF THE "REMOVAL OF LIGHTING UNIT, SALVAGE" PAY ITEM.
- SEE IDOT STANDARD DRAWING BE-900 FOR ADDITIONAL INSTALLATION DETAILS FOR PROPOSED SUSPENDED MOUNT UNDERPASS LUMINAIRES. SUSPENDED MOUNT UNDERPASS LUMINAIRES SETBACK FROM THE EDGE OF PAVEMENT SHALL BE 2 FEET.
- ALL PROPOSED UNDERPASS LIGHTING UNITS SHOWN ON THIS DRAWING WILL BE FED FROM EXISTING IDOT LIGHTING CONTROLLER "Z".
- ALL VERTICAL CONDUIT RUNS ROUTED DOWN THE STRUCTURE SHALL BE INSTALLED ON THE INSIDE OF THE PIER FACING AWAY FROM TRAFFIC FLOW.
- SEE DRAWING E-04 FOR CONTINUATION OF LIGHTING CIRCUIT.
- SEE IDOT STANDARD DRAWINGS BE-900 AND BE-902 FOR ATTACHING 3" CONDUIT SLEEVE TO THE ABUTMENT/PIER AND ROUTING IT DOWN INTO GRADE FOR FUTURE USE, UNLESS OTHERWISE NOTED.
- ALL UNDERPASS LUMINAIRES SHALL BE CENTERED BETWEEN THE STRUCTURAL BEAMS.

PROPOSED UNDERPASS LIGHTING PLAN

- THE INSTALLATION LOCATIONS OF THE UNDERPASS LUMINAIRES ARE SHOWN FOR THE ULTIMATE ROADWAY CONFIGURATION TO BE CONSTRUCTED IN FUTURE IDOT CONTRACT 60X97. SEE THE UNDERPASS LUMINAIRE TABLE FOR APPROXIMATE INSTALLATION LOCATIONS.
- PROVIDE TERMINAL BLOCKS AND 30A FUSES IN THE JUNCTION BOX FOR SPLICING THE NO. 10 UNDERPASS LIGHTING WIRES TO THE NO. 2 LIGHTING CIRCUIT WIRES.
- ROUTE NEW CONDUIT AND CABLES TO EXISTING JUNCTION BOX ATTACHED TO STRUCTURE AS SHOWN, CONNECT THE CABLES TO THE EXISTING LIGHTING CIRCUITS "ZE" AND "ZF" LOCATED IN THE JUNCTION BOX. PROVIDE ALL NECESSARY WORK TO CONNECT THE NEW TO EXISTING TO RESTORE THE CONTINUITY OF LIGHTING CIRCUITS "ZE" AND "ZF".

- 70 WATT, HPS UNDERPASS LUMINAIRE WITH TYPE 3 DISTRIBUTION
- 100 WATT, HPS UNDERPASS LUMINAIRE WITH TYPE 4 DISTRIBUTION

JUNCTION BOX SCHEDULE		
NO.	SIZE	DESCRIPTION
JB1	6"X6"X4"	STAINLESS STEEL, ATTACHED TO STRUCTURE, UNDERPASS LIGHTING
JB2	12"X10"X6"	STAINLESS STEEL, ATTACHED TO STRUCTURE, UNDERPASS LIGHTING
JB3	18"X18"X8"	STAINLESS STEEL, ATTACHED TO STRUCTURE, UNDERPASS LIGHTING

CABLE / CONDUIT SCHEDULE	
1	3-1/C*10, 1-1/C*10 GND IN 1" DIA PVCC RGC ATTACHED TO STRUCTURE (CKTS AS INDICATED ON THIS DRAWING)
2	2-1/C*10, 1-1/C*10 GND IN 1" DIA PVCC RGC ATTACHED TO STRUCTURE (CKTS AS INDICATED ON THIS DRAWING)
3	2-1/C*10, 1-1/C*10 GND IN 3/4" DIA LIQUID TIGHT FLEXIBLE CONDUIT (CKTS AS INDICATED ON THIS DRAWING)
4	3-1/C*2, 1-1/C*4 GND XLP TYPE USE CABLES IN A 1 1/2" UNIT DUCT (CKTS AS INDICATED ON THIS DRAWING)
5	3-1/C*2, 1-1/C*4 GND XLP TYPE USE CABLES IN A 3" DIA. PVCC RGC ATTS (CKTS AS INDICATED ON THIS DRAWING)



D160X78-sh-t-Light-06	DESIGNED - WDS	REVISED -
USER NAME = myersc	DRAWN - CAM	REVISED -
PLOT SCALE = 40.0000' / in.	CHECKED - WDS	REVISED -
PLOT DATE = 3/17/2016	DATE - 3/18/2016	REVISED -

STATE OF ILLINOIS
DEPARTMENT OF TRANSPORTATION

WB I-9094 UNDERPASS LIGHTING PLAN

SCALE: 1"=20' SHEET 6 OF 13 SHEETS STA. TO STA.

F.A.I. RTE.	SECTION	COUNTY	TOTAL SHEETS	SHEET NO.
90/94/290	2014-004R&B	COOK	706	158
CONTRACT NO. 60X78				

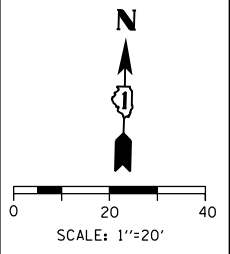

E-06

FILE PATH = p:\16179-P\INT\rescom\line\loc\16179\60X78\60X78-06\60X78-sh-t-Light-06

FILE PATH = p:\6179-PMINT\aecon\line\local\AECDM_D902_NA\Documents\01_Americas\T\engor\ation\60269438_Circle\Phase_1\1000_CAD\016_Electrical\Sheets\60X78_Contract\0160X78_sht-Light-07

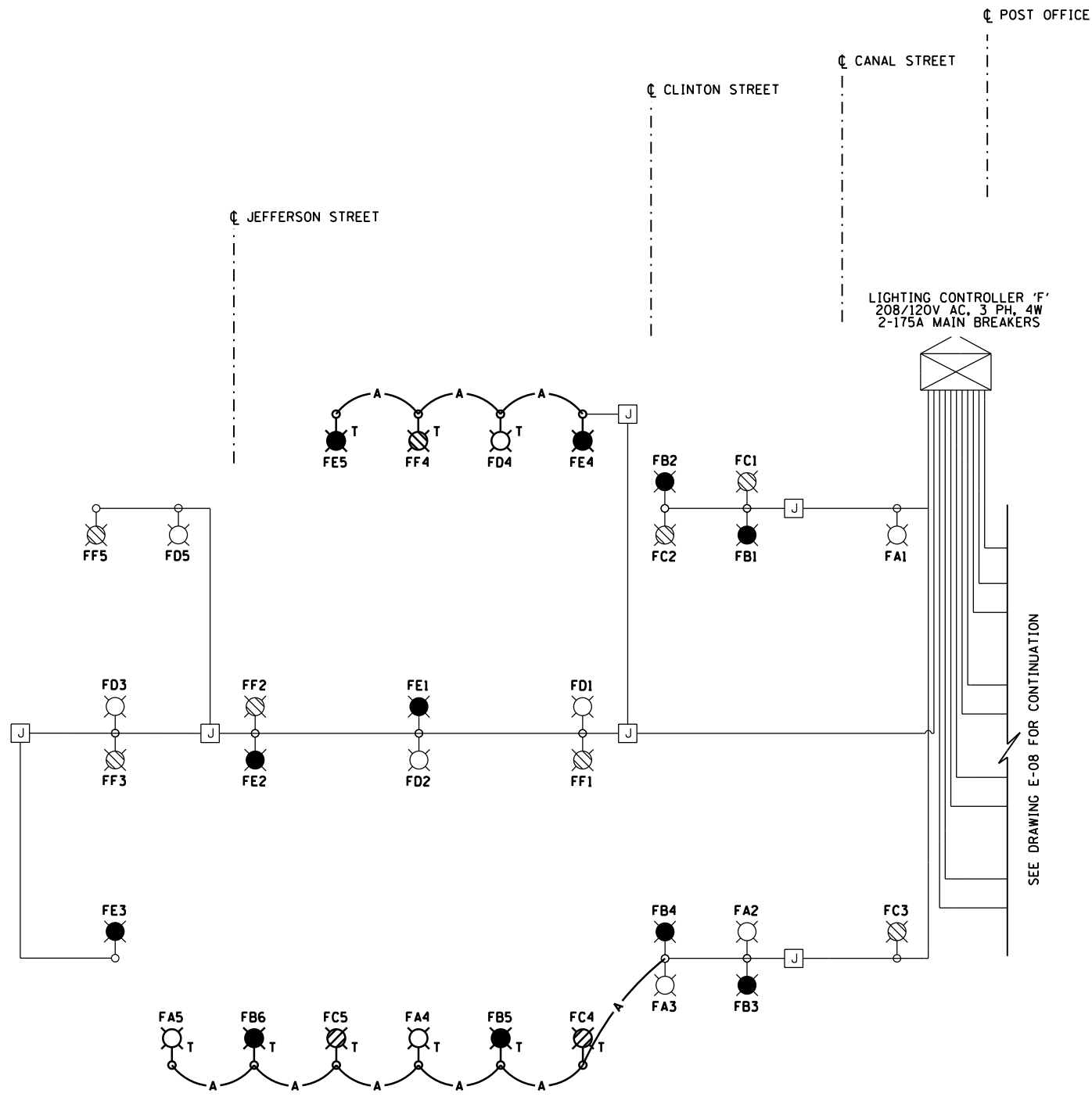

SYMBOLS LEGEND

- IDOT LIGHTING CONTROLLER
- JUNCTION BOX
- LIGHTING UNIT (400W LUMINAIRE)
(RED PHASE - OPEN SYMBOL
BLACK PHASE - SOLID SYMBOL
BLUE PHASE - STRIPED)
- TWIN ARM LIGHTING UNIT (400W LUMINAIRE)
(RED PHASE - OPEN SYMBOL
BLACK PHASE - SOLID SYMBOL
BLUE PHASE - STRIPED)
- LIGHTING UNIT (200W LUMINAIRE)
(RED PHASE - OPEN SYMBOL
BLACK PHASE - SOLID SYMBOL
BLUE PHASE - STRIPED)
- TWIN ARM LIGHTING UNIT (200W LUMINAIRE)
(RED PHASE - OPEN SYMBOL
BLACK PHASE - SOLID SYMBOL
BLUE PHASE - STRIPED)
- UNDERPASS LIGHTING UNIT
400 WATT HPS LUMINAIRE
(RED PHASE - OPEN SYMBOL
BLACK PHASE - SOLID SYMBOL
BLUE PHASE - STRIPED)
- UNDERPASS LIGHTING UNIT
55 WATT LPS LUMINAIRE
(RED PHASE - OPEN SYMBOL
BLACK PHASE - SOLID SYMBOL
BLUE PHASE - STRIPED)
- TEMPORARY LIGHTING UNIT
(400W LUMINAIRE)
(RED PHASE - OPEN SYMBOL
BLACK PHASE - SOLID SYMBOL
BLUE PHASE - STRIPED)
- TEMPORARY AERIAL CABLE

LOAD TABLE LIGHTING CONTROLLER "F"								
CIRCUIT	RED PHASE		CIRCUIT	BLACK PHASE		CIRCUIT	BLUE PHASE	
	AMPS	WATTS		AMPS	WATTS		AMPS	WATTS
A	19.0	2280	B	22.8	2736	C	19.0	2280
D	19.0	2280	E	19.0	2280	F	19.0	2280
G	7.38	886	H	32.64	3917	I	9.84	1181
J	7.38	886	K	25.04	3005	L	25.04	3005
M	7.38	886	N	9.84	1181	O	9.84	1181
P	7.38	886	Q	9.84	1181	R	9.84	1181
S	-	-	T	-	-	U	-	-
V	-	-	W	-	-	X	-	-
TOTAL	67.52	8,104	TOTAL	119.2	14,300	TOTAL	92.6	11,110



E-07



D160X78-sht-Light-07
 USER NAME = myersc
 PLOT SCALE = 40.0000' / in.
 PLOT DATE = 3/17/2016

DESIGNED - WDS
 DRAWN - CAM
 CHECKED - WDS
 DATE - 3/18/2016

REVISED -
 REVISED -
 REVISED -
 REVISED -

STATE OF ILLINOIS
 DEPARTMENT OF TRANSPORTATION







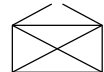

IDOT LIGHTING CONTROLLER 'F'
 WIRING DIAGRAM - PART 1

SCALE: N.T.S. SHEET 7 OF 13 SHEETS STA. TO STA.

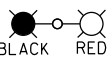
F.A.I. RE.	SECTION	COUNTY	TOTAL SHEETS	SHEET NO.
90/94/290	2014-004R&B	COOK	706	159
CONTRACT NO. 60X78				
ILLINOIS FED. AID PROJECT				

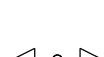
POST OFFICE

SYMBOLS LEGEND

-  IDOT LIGHTING CONTROLLER
-  JUNCTION BOX
-  LIGHTING UNIT (400W LUMINAIRE)
(RED PHASE - OPEN SYMBOL
BLACK PHASE - SOLID SYMBOL
BLUE PHASE - STRIPED)
-  TWIN ARM LIGHTING UNIT (400W LUMINAIRE)
(RED PHASE - OPEN SYMBOL
BLACK PHASE - SOLID SYMBOL
BLUE PHASE - STRIPED)
-  LIGHTING UNIT (200W LUMINAIRE)
(RED PHASE - OPEN SYMBOL
BLACK PHASE - SOLID SYMBOL
BLUE PHASE - STRIPED)
-  TWIN ARM LIGHTING UNIT (200W LUMINAIRE)
(RED PHASE - OPEN SYMBOL
BLACK PHASE - SOLID SYMBOL
BLUE PHASE - STRIPED)
-  UNDERPASS LIGHTING UNIT
400 WATT HPS LUMINAIRE
(RED PHASE - OPEN SYMBOL
BLACK PHASE - SOLID SYMBOL
BLUE PHASE - STRIPED)
-  UNDERPASS LIGHTING UNIT
55 WATT LPS LUMINAIRE
(RED PHASE - OPEN SYMBOL
BLACK PHASE - SOLID SYMBOL
BLUE PHASE - STRIPED)
-  TEMPORARY LIGHTING UNIT
(400W LUMINAIRE)
(RED PHASE - OPEN SYMBOL
BLACK PHASE - SOLID SYMBOL
BLUE PHASE - STRIPED)
-  TEMPORARY AERIAL CABLE

LIGHTING CONTROLLER 'F'
208/120V AC, 3 PH, 4W
2-175A MAIN BREAKERS

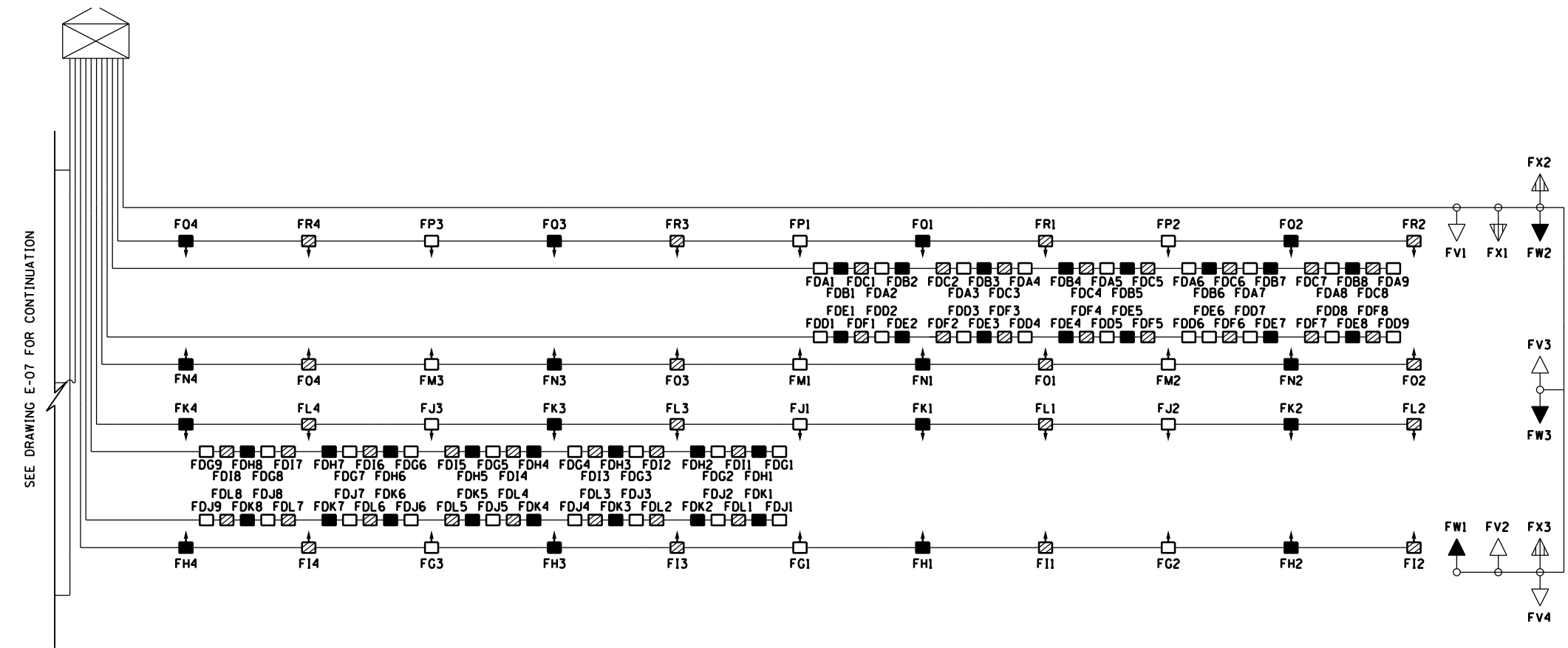

FILE PATH = p:\6179-PMINT\ecomonline\local\AECOM\0502_NA\Documents\01_Americas\T\engor-tation\60269338_Circle\Phase_11\000_CAD\016_Electrical\Sheets\60X78_Contract\0160X78-sht-Light-08



D160X78-sht-Light-08	DESIGNED - WDS	REVISED -
USER NAME = myersc	DRAWN - CAM	REVISED -
PLOT SCALE = 40.0000' / in.	CHECKED - WDS	REVISED -
PLOT DATE = 3/17/2016	DATE - 3/18/2016	REVISED -

STATE OF ILLINOIS
DEPARTMENT OF TRANSPORTATION



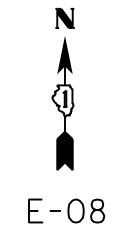

IDOT LIGHTING CONTROLLER 'F'
WIRING DIAGRAM - PART 2

SCALE: N.T.S. SHEET 8 OF 13 SHEETS STA. TO STA.

F.A.I. RTE.	SECTION	COUNTY	TOTAL SHEETS	SHEET NO.
90/94/290	2014-004R&B	COOK	706	160
CONTRACT NO. 60X78			ILLINOIS FED. AID PROJECT	



SYMBOLS LEGEND

-  IDOT LIGHTING CONTROLLER
-  JUNCTION BOX
-  UNDERPASS LIGHTING UNIT
55 WATT LPS LUMINAIRE
(BLACK PHASE - SOLID SYMBOL
RED PHASE - OPEN SYMBOL)
-  HIGH MAST LIGHT TOWER
400 WATT HPS LUMINAIRE
(BLACK PHASE - SOLID SYMBOL
RED PHASE - OPEN SYMBOL)
-  UNDERPASS LIGHTING UNIT
70 OR 100 WATT HPS LUMINAIRE
(BLACK PHASE - SOLID SYMBOL
RED PHASE - OPEN SYMBOL)

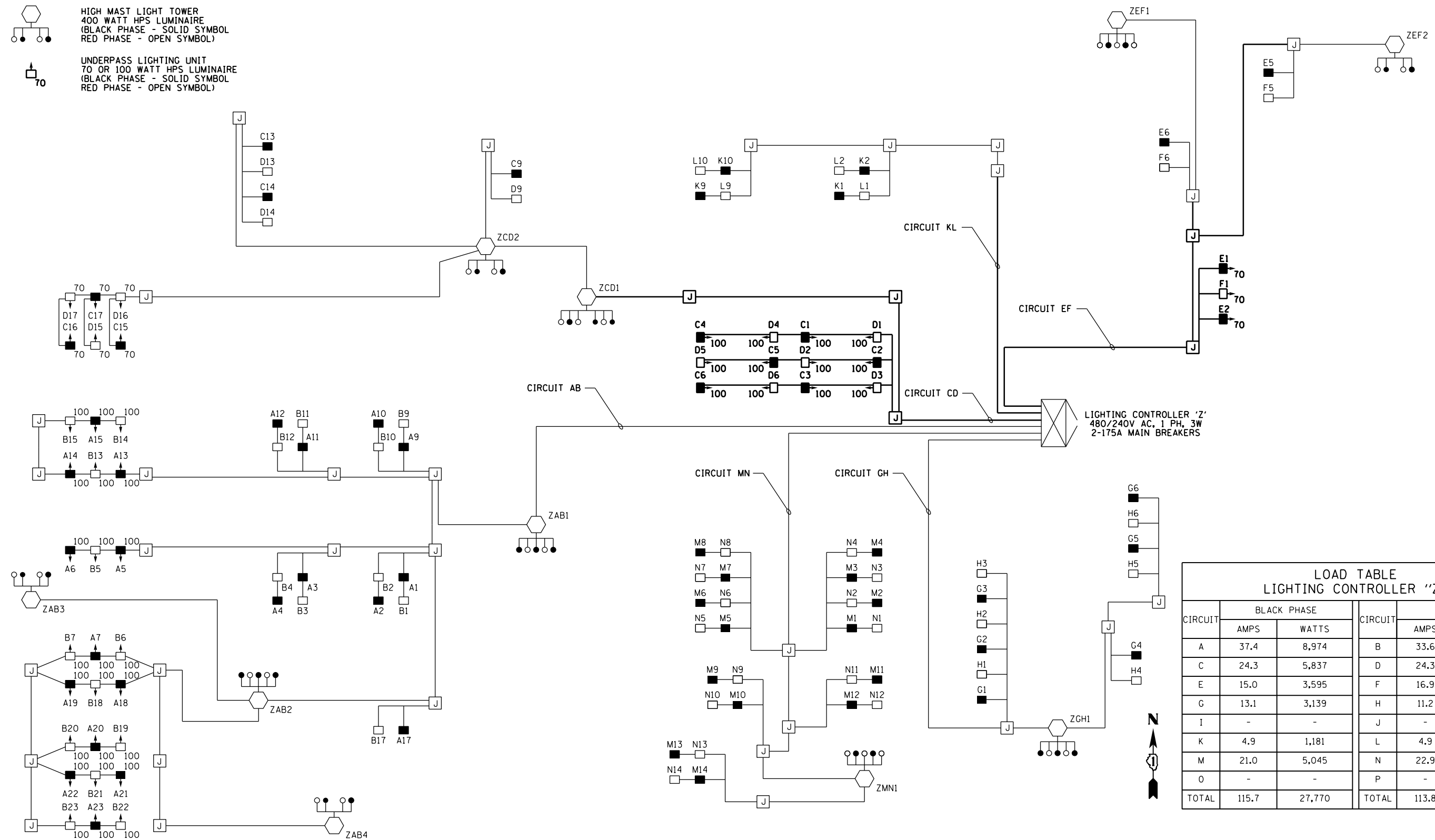

**LOAD TABLE
LIGHTING CONTROLLER "Z"**

CIRCUIT	BLACK PHASE		RED PHASE		
	AMPS	WATTS	AMPS	WATTS	
A	37.4	8,974	B	33.6	8,062
C	24.3	5,837	D	24.3	5,837
E	15.0	3,595	F	16.9	4,051
G	13.1	3,139	H	11.2	2,683
I	-	-	J	-	-
K	4.9	1,181	L	4.9	1,181
M	21.0	5,045	N	22.9	5,501
O	-	-	P	-	-
TOTAL	115.7	27,770	TOTAL	113.8	27,314

E-09

FILE PATH = p:\6179-P\INT\p\com\line\local\AECOM\0502_NA\Documents\01_Americas\T\engor\station\60269438_Circle\Phase_1\1000_Cad\016_Electrical\Sheets\60X78_Contract\0160X78-shr-Light-09



D160X78-shr-Light-09
 USER NAME = myersc
 PLOT SCALE = 40.0000' / in.
 PLOT DATE = 3/17/2016

DESIGNED - WDS
 DRAWN - CAM
 CHECKED - WDS
 DATE - 3/18/2016

REVISED -
 REVISED -
 REVISED -
 REVISED -

**STATE OF ILLINOIS
 DEPARTMENT OF TRANSPORTATION**

**IDOT LIGHTING CONTROLLER 'Z'
 WIRING DIAGRAM**

SCALE: N.T.S. SHEET 9 OF 13 SHEETS STA. TO STA.

F.A.I. RTE. 90/94/290	SECTION 2014-004R&B	COUNTY COOK	TOTAL SHEETS 706	SHEET NO. 161
CONTRACT NO. 60X78				
ILLINOIS FED. AID PROJECT				

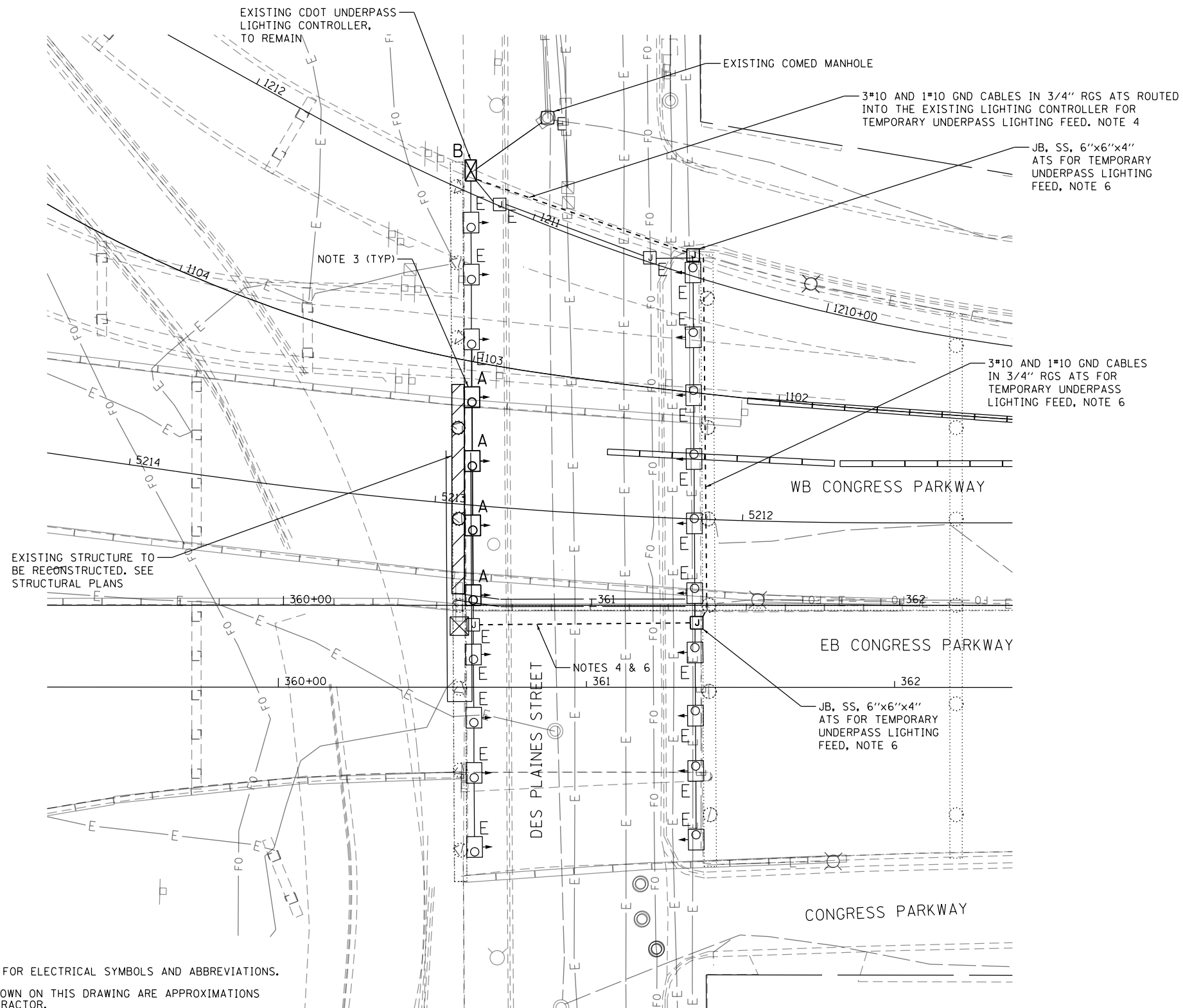

NOTES:

- SEE DRAWINGS RL-01 AND CDOT STANDARD NO. 826 FOR ELECTRICAL SYMBOLS AND ABBREVIATIONS.
- LOCATIONS OF EXISTING ELECTRICAL EQUIPMENT SHOWN ON THIS DRAWING ARE APPROXIMATIONS AND MUST BE VERIFIED IN THE FIELD BY THE CONTRACTOR.
- THE REMOVAL OF EXISTING UNDERPASS LUMINAIRES INCLUDES THE REMOVAL OF ALL CABLE, CONDUIT, JUNCTION BOXES AND HARDWARE ASSOCIATED WITH THE EXISTING UNDERPASS LIGHTING SYSTEM MADE OBSOLETE BY THE REMOVAL OF THE EXISTING LUMINAIRES. THE COST FOR THIS WORK WILL NOT BE PAID FOR SEPARATELY BUT WILL BE INCLUDED AS PART OF THE "RELOCATE EXISTING LUMINAIRE" PAY ITEM.
- ROUTE 3*10 AND 1*10 GND CABLES IN 3/4" RGS CONDUIT MOUNTED ON THE INSIDE FACE OF THE I-BEAM ACROSS DES PLAINES STREET TO THE NEAREST JUNCTION BOX UNEFFECTED BY CONSTRUCTION FOR A TEMPORARY FEED TO UNDERPASS LIGHTING CIRCUITS 1 AND 2 LOCATED ON THE WEST SIDE OF DES PLAINES STREET.
- THE EXISTING UNDERPASS LIGHTING SYSTEM FOR DES PLAINES STREET SHALL BE PROTECTED AND MAINTAINED THROUGHOUT THE DURATION OF THIS CONTRACT. THIS WORK WILL BE INCLUDED IN THE "PROTECTION AND MAINTENANCE OF EXISTING UNDERPASS LUMINAIRES" PAY ITEM.
- THE TEMPORARY LIGHTING FEED CAN BE REMOVED ONCE THE FINAL LIGHTING SYSTEM SHOWN ON E-11 HAS BEEN INSTALLED, ENERGIZED, TESTED AND APPROVED BY THE ENGINEER.

"A" REMOVE AND REINSTALL EXISTING UNDERPASS LIGHTING UNIT
 "B" EXISTING UNDERPASS LIGHTING CONTROLLER TO REMAIN
 "E" EXISTING TO REMAIN

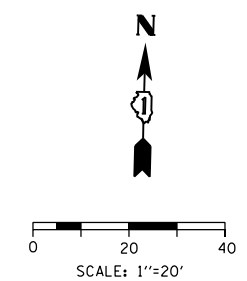

DATE	REVISION
CITY OF CHICAGO	
DEPARTMENT OF TRANSPORTATION DIVISION OF ENGINEERING	
CONSULTANT: AECOM <small>303 EAST WACKER DRIVE, SUITE 1400 CHICAGO, IL 60601-5276 PHONE: (312) 373-7700 FAX: (312) 373-6800</small>	
WORK ORDER NO. _____	DATE _____
COST ALLOCATION ACCOUNT _____	
APPROPRIATION ACCOUNT _____	MATERIAL _____ LABOR _____
DES PLAINES STREET EXISTING UNDERPASS LIGHTING PLAN (CDOT)	
CITY OF CHICAGO DEPT. OF TRANSPORTATION DIVISION OF ELECTRICAL OPERATIONS	
DRAFTSMAN: CAM	CHIEF DRAFTSMAN: WDS
SUPERVISING ENGINEER: JPC	ELEC. DESIGN ENGR.
ENGINEER OF ELECTRICITY:	E-10
GEN'L SUPT. OF ELECTRICITY:	
DEPUTY COMMISSIONER:	
DATE: 3/18/2016	
C.D.O.T. PROJECT NO.:	DWG. NO.:

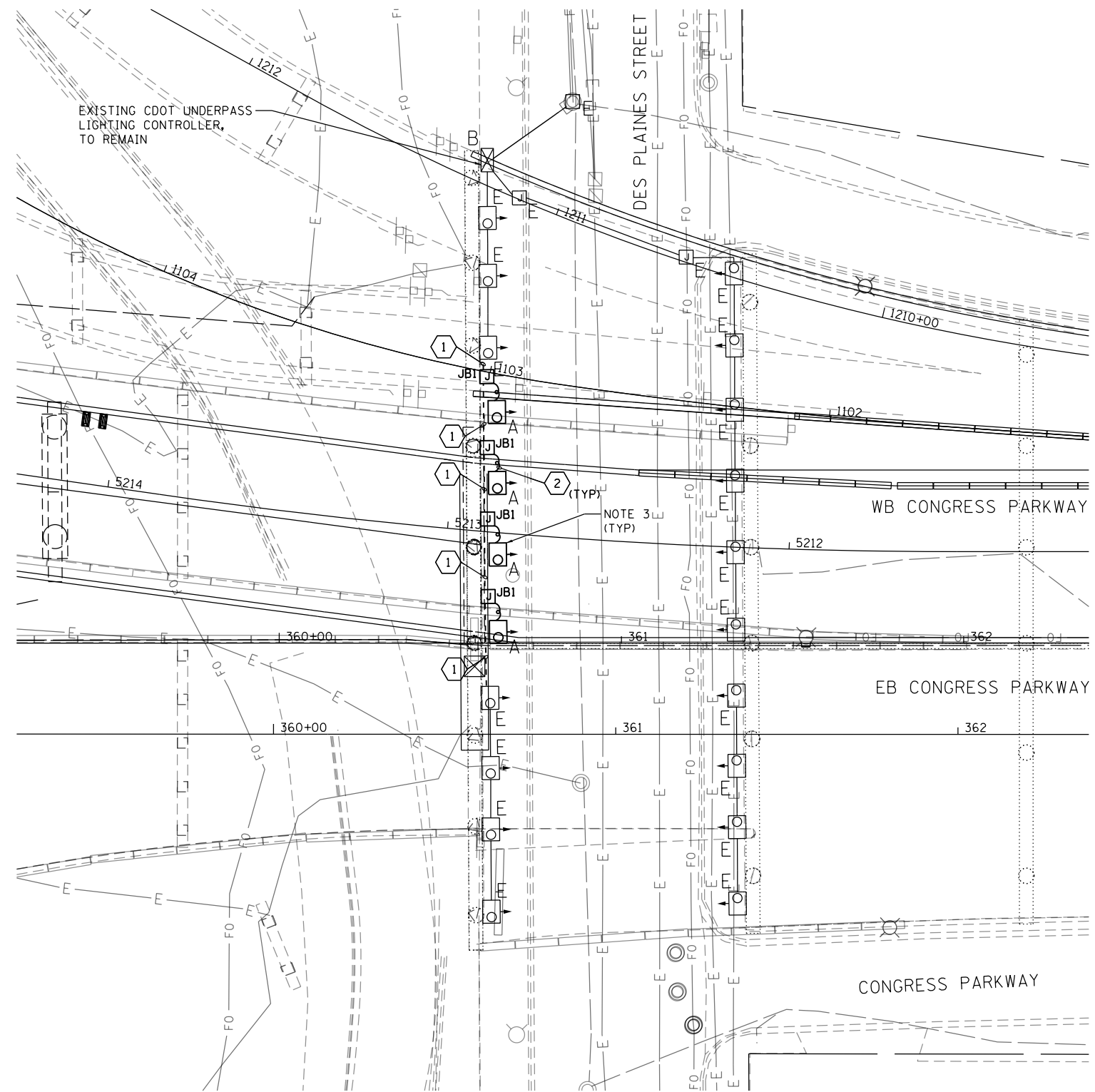

CABLE / CONDUIT SCHEDULE	
1	3*10 & 1*10 GND IN 3/4" DIA. RGS, ATS, NOTE 3
2	2*10 & 1*10 GND IN 3/4" DIA. LIQUID TIGHT, NON-METALLIC, FLEXIBLE CONDUIT, NOTE 3

JUNCTION BOX SCHEDULE		
NO.	SIZE	DESCRIPTION
JB1	6"x6"x4"	STAINLESS STEEL, ATTACHED TO STRUCTURE, UNDERPASS LIGHTING, NOTE 3

"A" REINSTALL EXISTING UNDERPASS LIGHTING UNIT ATTACHED TO STRUCTURE
 "B" EXISTING UNDERPASS LIGHTING CONTROLLER TO REMAIN
 "E" EXISTING TO REMAIN

- NOTES:**
- SEE DRAWINGS RL-01 AND CDOT STANDARD NO. 826 FOR ELECTRICAL SYMBOLS AND ABBREVIATIONS.
 - DIMENSIONS SHOWN ON THIS DRAWING ARE APPROXIMATE.
 - ALL WORK INCLUDING, BUT NOT LIMITED TO, CONDUITS, CONDUIT WHIPS, CABLES, JUNCTION BOXES AND APPURTENANCES NECESSARY TO REINSTALL AND RECONNECT THE EXISTING LUMINAIRES TO THE EXISTING UNDERPASS SYSTEM WILL NOT BE PAID FOR SEPARATELY AND SHALL BE INCLUDED IN THE COST OF THE "RELOCATE EXISTING LUMINAIRE" PAY ITEM.

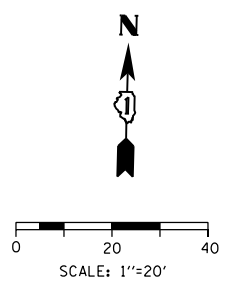

DATE	REVISION
CITY OF CHICAGO	
DEPARTMENT OF TRANSPORTATION DIVISION OF ENGINEERING	
CONSULTANT: <small>303 EAST WACKER DRIVE, SUITE 1400 CHICAGO, IL 60601-5276 PHONE: (312) 373-7700 FAX: (312) 373-6800</small>	
WORK ORDER NO. _____	DATE _____
COST ALLOCATION ACCOUNT _____	
APPROPRIATION ACCOUNT _____	MATERIAL _____ LABOR _____
DES PLAINES STREET FINAL UNDERPASS LIGHTING PLAN (CDOT)	
CITY OF CHICAGO DEPT. OF TRANSPORTATION DIVISION OF ELECTRICAL OPERATIONS	
DRAFTSMAN: CAM	ENGINEER: WDS
SUPERVISING ENGINEER: JPC	ELEC. DESIGN ENGR.
ENGINEER OF ELECTRICITY:	
GEN'L SUPT. OF ELECTRICITY:	
DEPUTY COMMISSIONER:	
SIZE: 22" 34"	SCALE: 1" = 20'
DATE: 3/18/2016	DATE: 3/18/2016
C.D.O.T. PROJECT NO.:	DWG. NO.: E-11
11 OF 13	

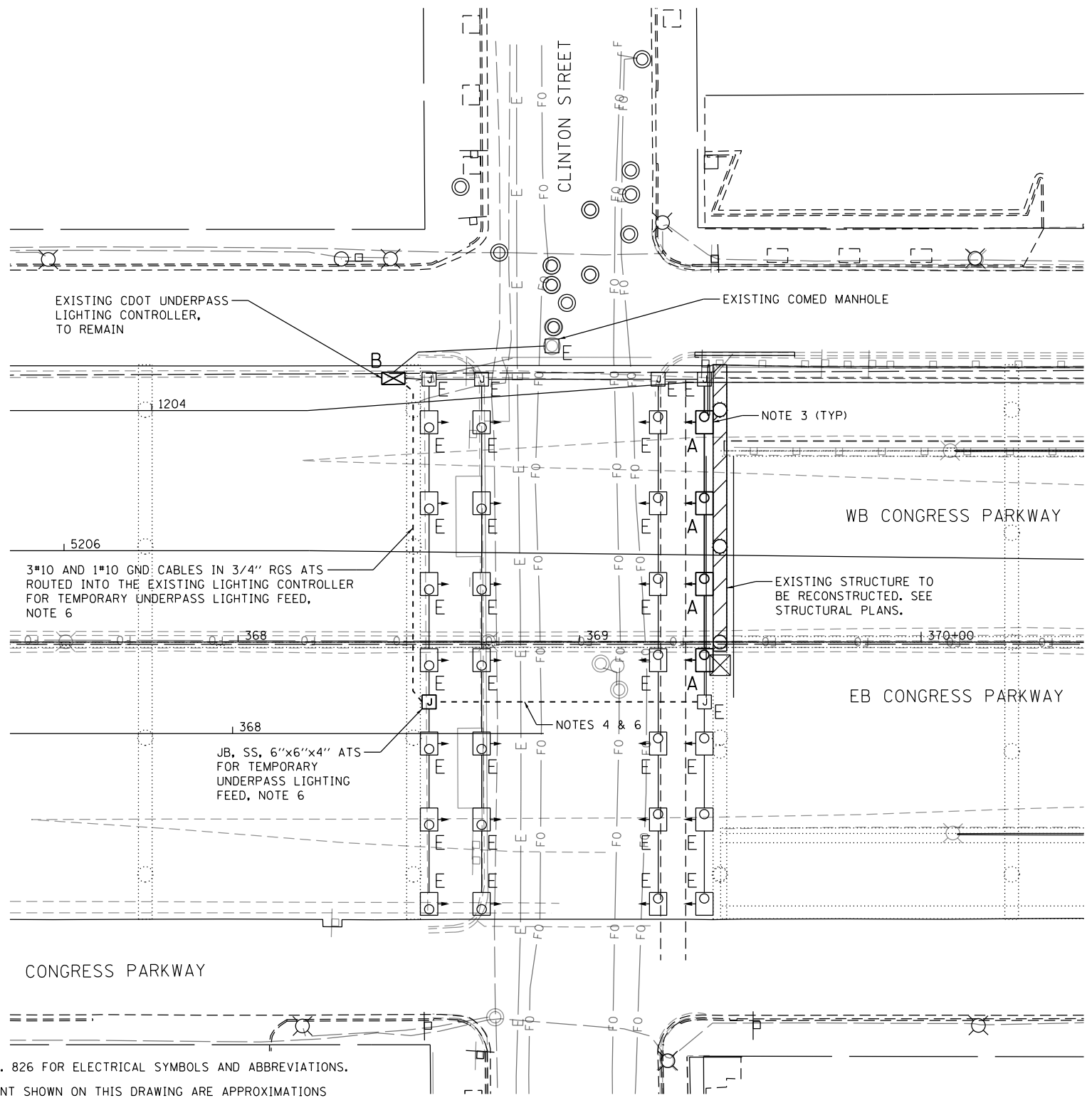

NOTES:

- SEE DRAWINGS RL-01 AND CDOT STANDARD NO. 826 FOR ELECTRICAL SYMBOLS AND ABBREVIATIONS.
- LOCATIONS OF EXISTING ELECTRICAL EQUIPMENT SHOWN ON THIS DRAWING ARE APPROXIMATIONS AND MUST BE VERIFIED IN THE FIELD BY THE CONTRACTOR.
- THE REMOVAL OF EXISTING UNDERPASS LUMINAIRES INCLUDES THE REMOVAL OF ALL CABLE, CONDUIT, JUNCTION BOXES AND HARDWARE ASSOCIATED WITH THE EXISTING UNDERPASS LIGHTING SYSTEM MADE OBSOLETE BY THE REMOVAL OF THE EXISTING LUMINAIRES. THE COST FOR THIS WORK WILL NOT BE PAID FOR SEPARATELY BUT WILL BE INCLUDED AS PART OF THE "RELOCATE EXISTING LUMINAIRE" PAY ITEM.
- ROUTE 3*10 AND 1*10 GND CABLES IN 3/4" RGS CONDUIT MOUNTED ON THE INSIDE FACE OF THE I-BEAM ACROSS CLINTON STREET FROM A PROPOSED JUNCTION BOX TO THE NEAREST JUNCTION BOX UNEFFECTED BY CONSTRUCTION FOR A TEMPORARY FEED TO THE EXISTING UNDERPASS LIGHTING CIRCUITS TO REMAIN LOCATED ON THE EAST SIDE OF CLINTON STREET.
- THE EXISTING UNDERPASS LIGHTING SYSTEM FOR CLINTON STREET SHALL BE PROTECTED AND MAINTAINED THROUGHOUT THE DURATION OF THIS CONTRACT. THIS WORK WILL BE INCLUDED IN THE "PROTECTION AND MAINTENANCE OF EXISTING UNDERPASS LUMINAIRES" PAY ITEM.
- THE TEMPORARY LIGHTING FEED CAN BE REMOVED ONCE THE FINAL LIGHTING SYSTEM SHOWN ON E-13 HAS BEEN INSTALLED, ENERGIZED, TESTED AND APPROVED BY THE ENGINEER.

"A" REMOVE AND REINSTALL EXISTING UNDERPASS LIGHTING UNIT
 "B" EXISTING UNDERPASS LIGHTING CONTROLLER TO REMAIN
 "E" EXISTING TO REMAIN

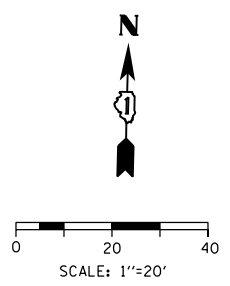

DATE	REVISION
CITY OF CHICAGO DEPARTMENT OF TRANSPORTATION DIVISION OF ENGINEERING	
CONSULTANT: <div style="text-align: center;"> <small>303 EAST WACKER DRIVE, SUITE 1400 CHICAGO, IL 60601-5276 PHONE: (312) 373-7700 FAX: (312) 373-6800</small> </div>	
WORK ORDER NO. _____	DATE _____
COST ALLOCATION ACCOUNT _____	
APPROPRIATION ACCOUNT _____	MATERIAL _____ LABOR _____
CLINTON STREET EXISTING UNDERPASS LIGHTING PLAN (CDOT)	
CITY OF CHICAGO <small>DEPT. OF TRANSPORTATION DIVISION OF ELECTRICAL OPERATIONS</small>	
DRAFTSMAN: CAM	ENGINEER: WDS
SUPERVISING ENGINEER: JPC	ELEC. DESIGN ENGR.
ENGINEER OF ELECTRICITY:	
GEN'L SUPT. OF ELECTRICITY:	
DEPUTY COMMISSIONER:	
SIZE: 22" 34"	SCALE: 1" = 20'
DATE: 3/18/2016	DATE: 3/18/2016
C.D.O.T. PROJECT NO.:	DWG. NO.: E-12
12 OF 13	

CABLE / CONDUIT SCHEDULE	
1	3*10 & 1*10 GND IN 3/4" DIA. RGS, ATS, NOTE 3
2	2*10 & 1*10 GND IN 3/4" DIA. LIQUID TIGHT, NON-METALLIC, FLEXIBLE CONDUIT, NOTE 3

JUNCTION BOX SCHEDULE		
NO.	SIZE	DESCRIPTION
JB1	6"x6"x4"	STAINLESS STEEL, ATTACHED TO STRUCTURE, UNDERPASS LIGHTING, NOTE 3

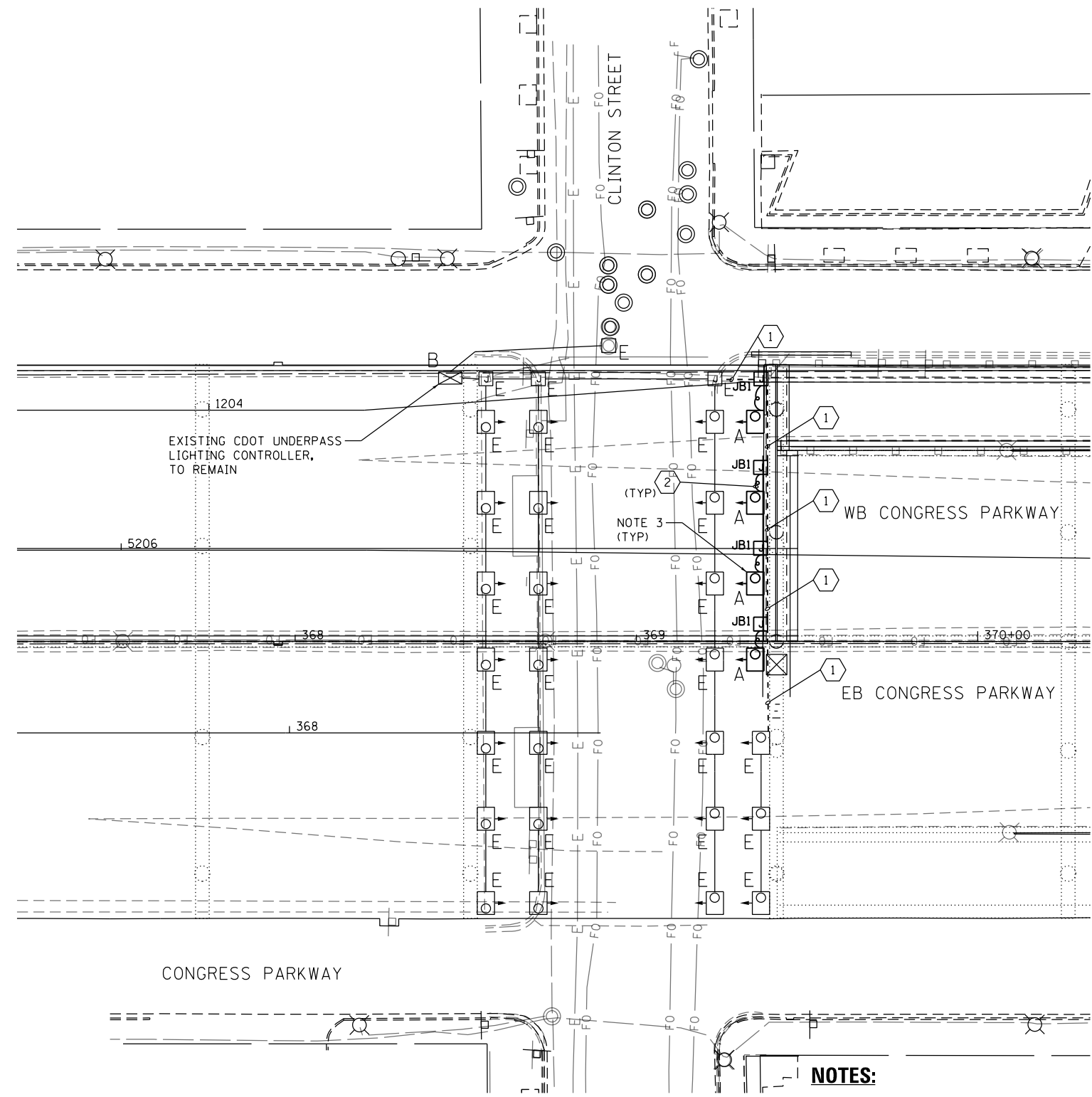

"A"	REINSTALL EXISTING UNDERPASS LIGHTING UNIT ATTACHED TO STRUCTURE
"B"	EXISTING UNDERPASS LIGHTING CONTROLLER TO REMAIN
"E"	EXISTING TO REMAIN

NOTES:

- SEE DRAWINGS RL-01 AND CDOT STANDARD NO. 826 FOR ELECTRICAL SYMBOLS AND ABBREVIATIONS.
- DIMENSIONS SHOWN ON THIS DRAWING ARE APPROXIMATE. THE CONTRACTOR SHALL CENTER THE SUSPENDED MOUNT LUMINAIRES BETWEEN BRIDGE GIRDERS.
- ALL WORK INCLUDING, BUT NOT LIMITED TO, CONDUITS, CONDUIT WHIPS, CABLES, JUNCTION BOXES AND APPURTENANCES NECESSARY TO REINSTALL AND RECONNECT TO THE EXISTING UNDERPASS SYSTEM WILL NOT BE PAID FOR SEPARATELY AND SHALL BE INCLUDED IN THE COST OF THE "RELOCATE EXISTING LUMINAIRE" PAY ITEM.

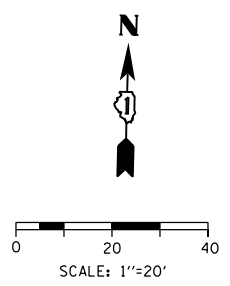

DATE	REVISION
CITY OF CHICAGO	
DEPARTMENT OF TRANSPORTATION DIVISION OF ENGINEERING	
CONSULTANT: AECOM <small>303 EAST WACKER DRIVE, SUITE 1400 CHICAGO, IL 60601-5276 PHONE: (312) 373-7700 FAX: (312) 373-6800</small>	
WORK ORDER NO. _____	DATE _____
COST ALLOCATION ACCOUNT _____	
APPROPRIATION ACCOUNT _____	MATERIAL _____ LABOR _____
CLINTON STREET FINAL UNDERPASS LIGHTING PLAN (CDOT)	
CITY OF CHICAGO DEPT. OF TRANSPORTATION DIVISION OF ELECTRICAL OPERATIONS	
DRAFTSMAN: CAM	CHIEF DRAFTSMAN: WDS
SUPERVISING ENGINEER: JPC	ELEC. DESIGN ENGR.
ENGINEER OF ELECTRICITY:	
GEN'L SUPT. OF ELECTRICITY:	
DEPUTY COMMISSIONER:	
SIZE: 22" 34"	SCALE: 1" = 20'
DATE: 3/18/2016	DATE: 3/18/2016
C.D.O.T. PROJECT NO.:	DWG. NO.: E-13
13 OF 13	

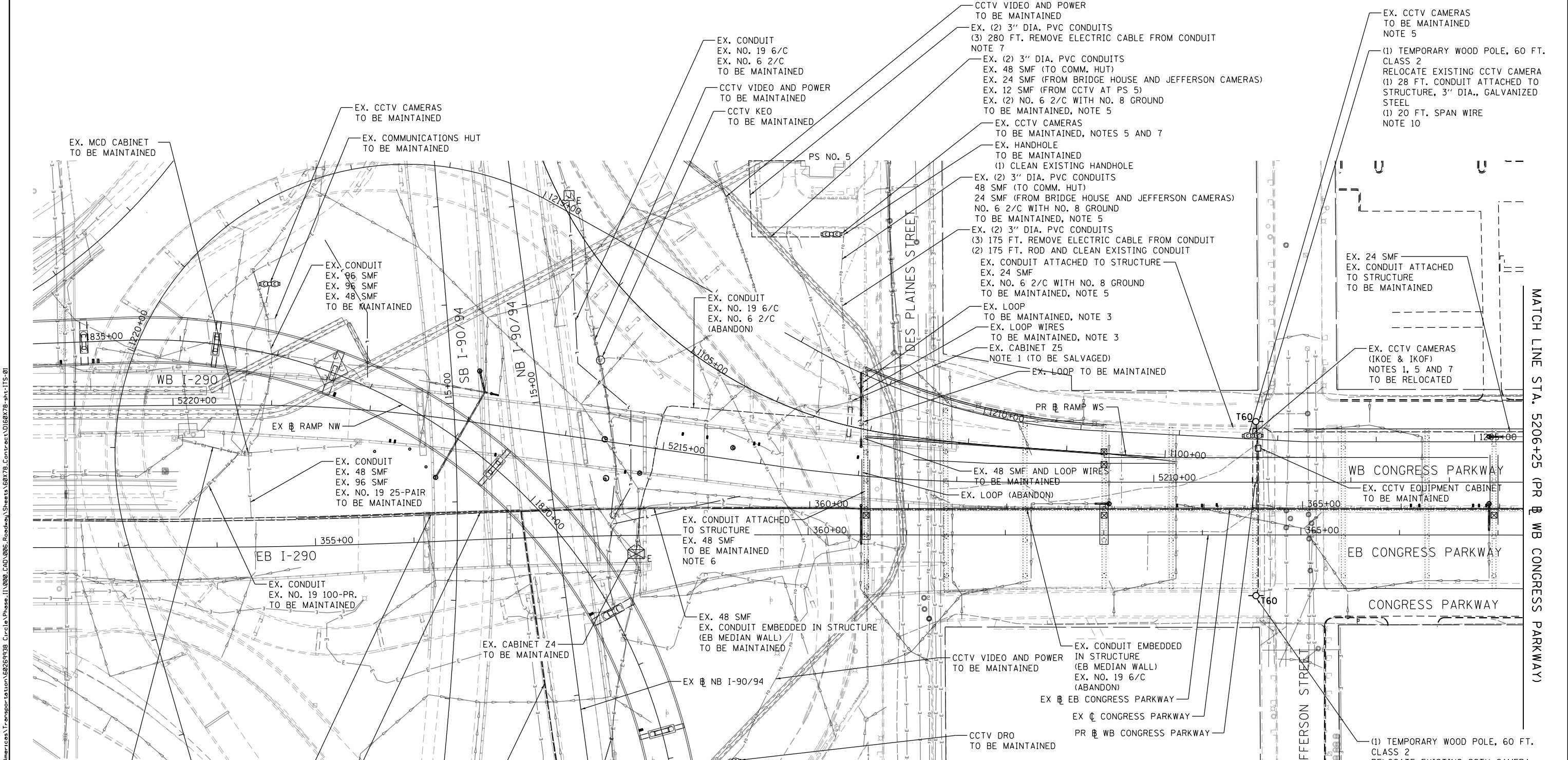

EX. MCD CABINET
TO BE MAINTAINED

EX. CCTV CAMERAS
TO BE MAINTAINED

EX. CONDUIT
EX. NO. 19 6/C
EX. NO. 6 2/C
TO BE MAINTAINED

CCTV VIDEO AND POWER
TO BE MAINTAINED

EX. CCTV CAMERAS
TO BE MAINTAINED
NOTE 5

WB I-290
5220+00

EX. CONDUIT
EX. 96 SMF
EX. 96 SMF
EX. 48 SMF
TO BE MAINTAINED

EX. CONDUIT
EX. NO. 19 6/C
EX. NO. 6 2/C
(ABANDON)

EX. (2) 3" DIA. PVC CONDUITS
(3) 280 FT. REMOVE ELECTRIC CABLE FROM CONDUIT
NOTE 7

(1) TEMPORARY WOOD POLE, 60 FT.
CLASS 2
RELOCATE EXISTING CCTV CAMERA
TO STRUCTURE, 3" DIA., GALVANIZED
STEEL

EB I-290
355+00

EX. CONDUIT
EX. 48 SMF
EX. 96 SMF
EX. NO. 19 25-PAIR
TO BE MAINTAINED

EX. CONDUIT ATTACHED
TO STRUCTURE
EX. 48 SMF
TO BE MAINTAINED
NOTE 6

EX. (2) 3" DIA. PVC CONDUITS
48 SMF (TO COMM. HUT)
24 SMF (FROM BRIDGE HOUSE AND JEFFERSON CAMERAS)
NO. 6 2/C WITH NO. 8 GROUND
TO BE MAINTAINED, NOTE 5

EX. 24 SMF
EX. CONDUIT ATTACHED
TO STRUCTURE
TO BE MAINTAINED

EX. CONDUIT
EX. NO. 19 100-PR.
TO BE MAINTAINED

EX. CABINET Z4
TO BE MAINTAINED

EX. 48 SMF
EX. CONDUIT EMBEDDED IN STRUCTURE
(EB MEDIAN WALL)
TO BE MAINTAINED

CCTV VIDEO AND POWER
TO BE MAINTAINED

EX. CCTV CAMERAS
(IKOE & IKOF)
NOTES 1, 5 AND 7
TO BE RELOCATED

EX. CONDUIT
EX. 96 SMF
EX. NO. 19 25-PR.
TO BE MAINTAINED

EX. CONDUIT EMBEDDED IN STRUCTURE
EX. 48 SMF
TO BE MAINTAINED
NOTE 6

NOTES:

1. REMOVE EXISTING SURVEILLANCE EQUIPMENT (SALVAGE) WHERE NOTED AND TURN OVER TO IDOT DISTRICT 1. THIS WORK WILL NOT BE PAID FOR SEPARATELY AND WILL BE INCLUDED IN THE COST OF THE "REMOVE EXISTING TRAFFIC SURVEILLANCE EQUIPMENT" PAY ITEM.
2. ALL EXISTING EQUIPMENT ATTACHED TO OR PART OF AN EXISTING STRUCTURE TO BE DEMOLISHED SHALL BE REMOVED AS PART OF THE STRUCTURAL REMOVAL PAY ITEMS, UNLESS OTHERWISE NOTED.
3. EXISTING I-290 WB RAMP LOOPS, CONDUITS AND CABLES ARE TO BE PROTECTED AND MAINTAINED FOR RECONNECTION.
4. MAINTAIN THE EXISTING IDOT ITS SYSTEMS THAT WILL BE AFFECTED BY THE CONSTRUCTION WORK. THIS ITS MAINTENANCE WORK SHALL BE INCLUDED IN THE COST OF THE "MAINTAINING ITS DURING CONSTRUCTION" PAY ITEM.
5. MAINTAIN EXISTING CCTV CAMERA POWER AND COMMUNICATIONS UNTIL TEMPORARY AND NEW INFRASTRUCTURE CAN BE INSTALLED. POWER AND COMMUNICATIONS FOR THE 100-FT POLE MOUNTED CCTV CAMERAS NEXT TO PS 5 ARE TO BE MAINTAINED AND WILL NOT BE REMOVED OR REPLACED.
6. THE 48 SMFO CABLE IN THE EB MEDIAN WALL IS TO BE ABANDONED WHEN THE REPLACEMENT 96 SMFO CABLE IN THE WB MEDIAN WALL BETWEEN PS 5 AND THE COMM. HUT IS INSTALLED.
7. THE 24 SMF CABLE, AND THE ELECTRIC CABLE NO. 6 2/C AND NO. 8 GOING TO THE EXISTING CCTV CAMERAS, AND THE EXISTING 48 SMF CABLE ARE TO BE MAINTAINED UNTIL NEW CABLES ARE TO BE INSTALLED. OTHER CABLES SHARING THE CONDUITS ARE TO REMAIN AND TO BE MAINTAINED. THESE ARE THE 12 SMF CABLE AND THE ELECTRIC CABLE NO. 6 2/C AND NO. 8 GOING TO THE CAMERA AT PS 5.
8. SEE THE SPECIAL PROVISION FOR CONTINUATION OF EX. OFF-SITE CAMERAS UNDER "BUDGETARY ALLOWANCE FOR TIME-LAPSE CAMERA".
9. LOCATIONS OF EX. IDOT ELECTRICAL/ITS EQUIPMENT SHOWN ON THIS SHEET ARE APPROXIMATIONS AND MUST BE VERIFIED IN THE FIELD BY THE CONTRACTOR.
10. RELOCATE CAMERA IKOE TO THE TEMPORARY WOOD POLE ON CONGRESS PARKWAY. RELOCATE CAMERA IKOF TO THE TEMPORARY WOOD POLE ON TILDEN STREET. THIS WORK WILL BE COVERED UNDER THE "RELOCATE EXISTING CCTV CAMERA" PAY ITEM. REFER TO IDOT STANDARD DRAWING BEB01 FOR AERIAL CABLE INSTALLATION.

EX. CONDUIT EMBEDDED
IN STRUCTURE
(EB MEDIAN WALL)
EX. NO. 19 6/C
(ABANDON)

(1) TEMPORARY WOOD POLE, 60 FT.
CLASS 2
RELOCATE EXISTING CCTV CAMERA
TO STRUCTURE, 3" DIA., GALVANIZED
STEEL

EX. CONDUIT ATTACHED TO STRUCTURE
EX. 96 SMF
EX. NO. 19 25-PAIR
TO BE MAINTAINED

EX. CONDUIT EMBEDDED IN STRUCTURE
EX. 96 SMF
EX. NO. 19 25-PAIR
TO BE MAINTAINED

EX. EB CONGRESS PARKWAY
EX. CONGRESS PARKWAY
PR. WB CONGRESS PARKWAY

WB CONGRESS PARKWAY
EX. CCTV EQUIPMENT CABINET
TO BE MAINTAINED

EB CONGRESS PARKWAY

CONGRESS PARKWAY

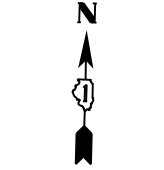

SCALE: 1"=50'

MATCH LINE STA. 5206+25 (PR. WB CONGRESS PARKWAY)

ITS-01



D160X78-sht-ITS-01	DESIGNED - GWS	REVISED -
USER NAME = dshevoz	DRAWN - CAM	REVISED -
PLOT SCALE = 100.0000' / in.	CHECKED - JDG	REVISED -
PLOT DATE = 4/27/2016	DATE - 3/18/2016	REVISED -

STATE OF ILLINOIS	EXISTING/MAINTAINING ITS PLAN	F.A.I. R.T.E.	SECTION	COUNTY	TOTAL SHEETS	SHEET NO.
DEPARTMENT OF TRANSPORTATION	WB I-290 OVER I-90/94 AND WB CONGRESS PARKWAY	90/94/290	2014-004R&B	COOK	706	166
						CONTRACT NO. 60X78
						ILLINOIS FED. AID PROJECT

SCALE: 1"=50'		SHEET 1 OF 20 SHEETS	STA. 5206+25 TO STA. 5221+50
---------------	--	----------------------	------------------------------

SCALE: 1"=50'		SHEET 1 OF 20 SHEETS	STA. 5206+25 TO STA. 5221+50
---------------	--	----------------------	------------------------------

SCALE: 1"=50'		SHEET 1 OF 20 SHEETS	STA. 5206+25 TO STA. 5221+50
---------------	--	----------------------	------------------------------

FILE PATH = p:\61779-PMINT\pcomon\line\local\AECOM\0902_NA\Documents\01_Americas\T\engor\station\60269338_Circle\Phase_1\1000_CAD\006_Roadway\Sheets\60X78_Contract\0160X78-shr-ITS-02

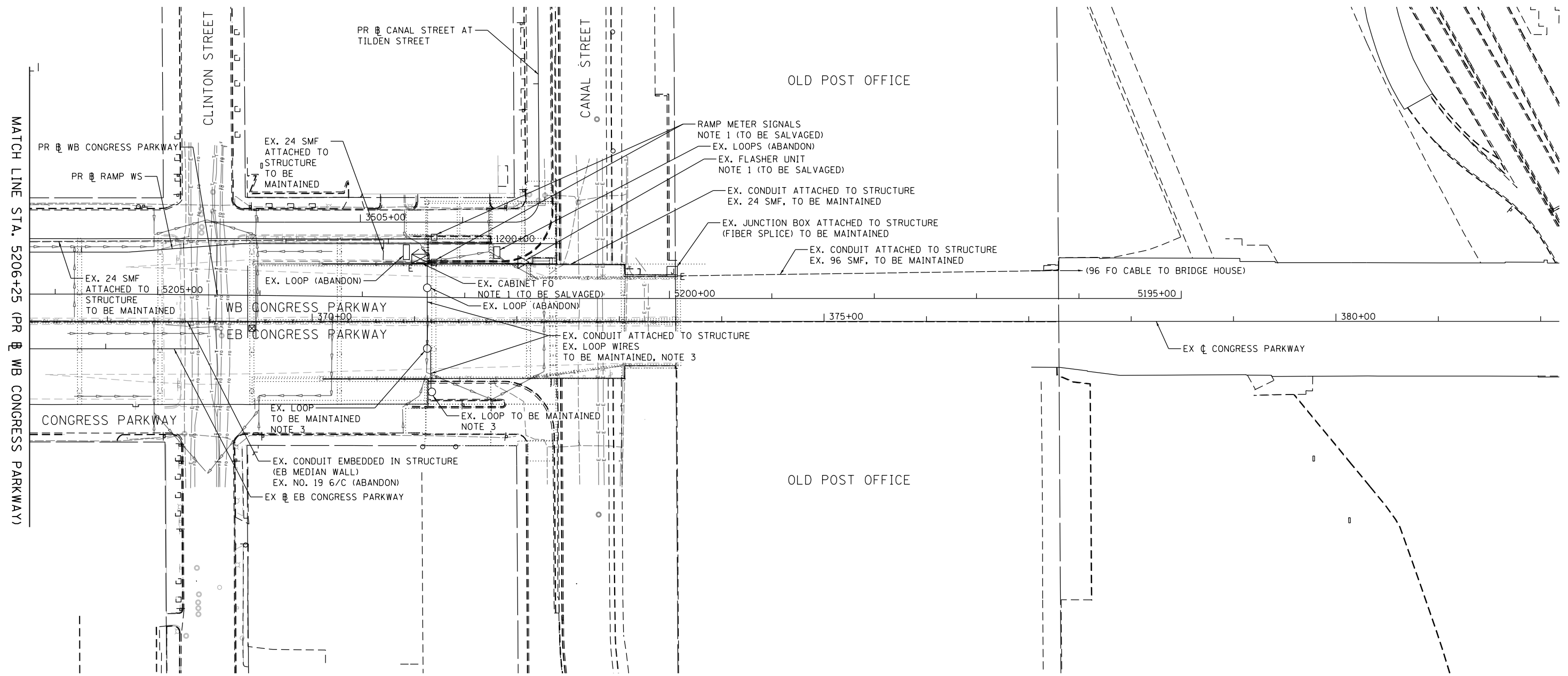

NOTES:

1. REMOVE EXISTING SURVEILLANCE EQUIPMENT (SALVAGE) WHERE NOTED AND TURN OVER TO IDOT DISTRICT 1. THIS WORK WILL NOT BE PAID FOR SEPARATELY AND WILL BE INCLUDED IN THE COST OF THE "REMOVE EXISTING TRAFFIC SURVEILLANCE EQUIPMENT" PAY ITEM.
2. ALL EXISTING EQUIPMENT ATTACHED TO OR PART OF AN EXISTING STRUCTURE TO BE DEMOLISHED SHALL BE REMOVED AS PART OF THE STRUCTURAL REMOVAL PAY ITEMS, UNLESS OTHERWISE NOTED.
3. EXISTING I-290 EB RAMP LOOPS, CONDUITS AND CABLES ARE TO BE PROTECTED AND MAINTAINED FOR RECONNECTION.
4. MAINTAIN THE EXISTING IDOT ITS SYSTEMS THAT WILL BE AFFECTED BY THE CONSTRUCTION WORK. THIS ITS MAINTENANCE WORK SHALL BE INCLUDED IN THE COST OF THE "MAINTAINING ITS DURING CONSTRUCTION" PAY ITEM.

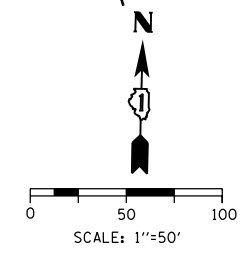

ITS-02



D160X78-shr-ITS-02	DESIGNED - GWS	REVISED -
USER NAME = myersc	DRAWN - CAM	REVISED -
PLOT SCALE = 100.0000' / in.	CHECKED - JDG	REVISED -
PLOT DATE = 3/17/2016	DATE - 3/18/2016	REVISED -

**STATE OF ILLINOIS
DEPARTMENT OF TRANSPORTATION**

EXISTING/MAINTAINING ITS PLAN			
WB I-290 OVER I-90/94 AND WB CONGRESS PARKWAY			
SCALE: 1"=50'	SHEET 2 OF 20 SHEETS	STA. 5195+00 TO STA. 5206+25	

F.A.I. RTE.	SECTION	COUNTY	TOTAL SHEETS	SHEET NO.
90/94/290	2014-004R&B	COOK	706	167
CONTRACT NO. 60X78				
ILLINOIS FED. AID PROJECT				

(2) 533 FT. CONDUIT EMBEDDED IN STRUCTURE, 2" DIA., PVC
 (1) 533 FT. FIBER OPTIC CABLE 96 FIBERS, SINGLE MODE
 100 FT. SLACK

(2) INTERCEPT EXISTING CONDUIT
 NOTE 1

EX. UNDERGROUND CONDUIT, PVC,
 4" DIA.
 (1) 70 FT. FIBER OPTIC CABLE 96
 FIBERS,
 SINGLE MODE

(1) FIBER OPTIC PATCH PANEL, 96F
 NOTE 8

DETAIL A & A2
 SEE SHEETS ITS-05
 AND ITS-06

(1) 397 FT. CONDUIT ATTACHED TO STRUCTURE, 3" DIA., PVC COATED GALVANIZED STEEL
 (9) 397 FT. ELECTRIC CABLE IN CONDUIT, LEAD-IN, NO. 18 4/C, TWISTED, SHIELDED
 (2) 397 FT. CONDUIT ATTACHED TO STRUCTURE, 2" DIA., PVC COATED GALVANIZED STEEL
 (1) 397 FT. FIBER OPTIC CABLE 96 FIBERS, SINGLE MODE, 100 FT. SLACK
 (1) 397 FT. ELECTRIC CABLE ASSEMBLY IN CONDUIT, 600V (XLP-TYPE TC) 2/C NO. 6 AND NO. 8

EXISTING CCTV EQUIPMENT CABINET

(1) 75 FT. CONDUIT ATS, 2" DIA.,
 PVC COATED G.S.
 (1) 75 FT. CONDUIT ATS, 2" DIA.,
 PVC COATED G.S.
 (1) 75 FT. FIBER OPTIC CABLE 12 FIBERS,
 SINGLE MODE, 50 FT. SLACK
 (1) 75 FT. ELECTRIC CABLE ASSEMBLY IN
 CONDUIT, 600V (XLP-TYPE TC) 2/C NO. 6
 AND NO. 8
 (1) FIBER OPTIC SPLICE - LATERAL
 NOTES 2 AND 11

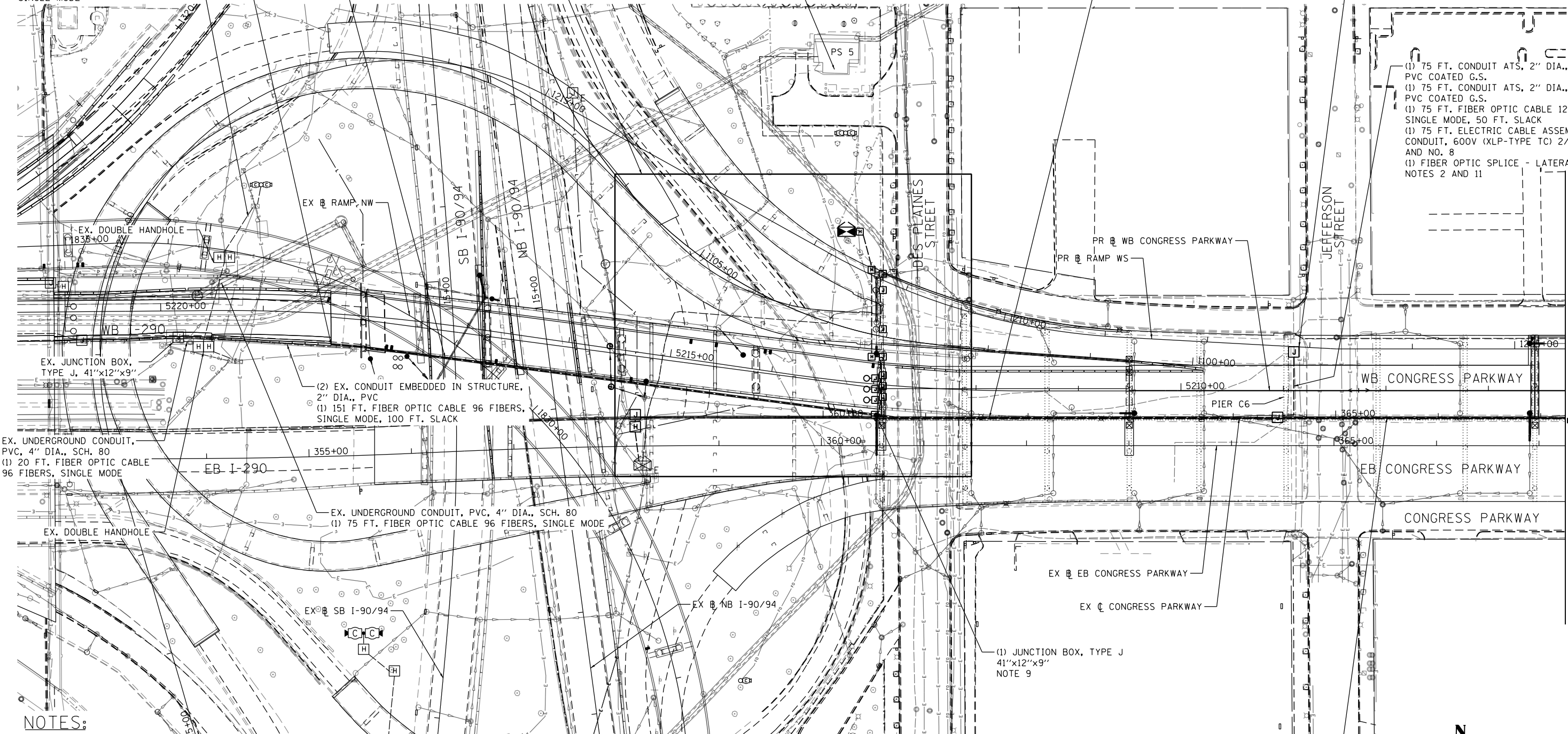

EX. UNDERGROUND CONDUIT,
 PVC, 4" DIA., SCH. 80
 (1) 20 FT. FIBER OPTIC CABLE
 96 FIBERS, SINGLE MODE

(2) EX. CONDUIT EMBEDDED IN STRUCTURE,
 2" DIA., PVC
 (1) 151 FT. FIBER OPTIC CABLE 96 FIBERS,
 SINGLE MODE, 100 FT. SLACK

EX. UNDERGROUND CONDUIT, PVC, 4" DIA., SCH. 80
 (1) 75 FT. FIBER OPTIC CABLE 96 FIBERS, SINGLE MODE

(1) JUNCTION BOX, TYPE J
 41"x12"x9"
 NOTE 9

NOTES:

- COORDINATE CONDUIT INSTALLATION WITH 60X77 CONTRACTOR. 2-2" EMBEDDED PVC CONDUITS CONTINUE TO THE WEST UNDER PROJECT 60X77.
- SEE DETAIL B ON SHEET ITS-07.
- DROP OUT 2 - 2" PVC CONDUITS FROM BOTTOM OF TYPE J JUNCTION BOX AND CONNECT TO THE 2-2" G.S. CONDUITS ATTACHED TO STRUCTURE. SEE ITS CONDUIT EXPANSION DETAIL, SHEET ITS-14.
- ALL FIBER OPTIC CABLES ARE TO MATCH EXISTING FIBER/SPLICE/TERMINATIONS.
- LOCATIONS OF EXISTING IDOT ELECTRICAL/ITS EQUIPMENT SHOWN ON THIS SHEET ARE APPROXIMATIONS AND MUST BE VERIFIED IN THE FIELD BY THE CONTRACTOR.
- ALL WORK SHOWN ON THIS SHEET MUST BE COORDINATED WITH THIS CONTRACT'S CONSTRUCTION WORK AND STAGING.
- THE LOCATIONS OF THE ITS EQUIPMENT SHOWN ON THE PLAN ARE APPROXIMATIONS. THE FINAL INSTALLATION LOCATIONS OF THE ITS EQUIPMENT SHALL BE STAKED IN THE FIELD AND APPROVED BY THE ENGINEER PRIOR TO BEGINNING ANY WORK TO ENSURE THAT THERE ARE NO CONFLICTS WITH EXISTING/PROPOSED UTILITIES AND WORK PERFORMED BY OTHER DISCIPLINES.
- REPLACE THE EXISTING 48F FIBER OPTIC PATCH PANEL IN PUMP STATION 5 WITH A 96F PANEL.
- THIS JUNCTION BOX IS EMBEDDED IN THE SOUTH PARAPET WALL AT APPROX. STA. 5212+98 LT. SEE DETAIL SHEET ITS-14 FOR CONDUIT DROP-OUTS TO CONNECT TO CONDUITS ATTACHED TO THE PIER STRUCTURE.
- CONTACT THE IDOT BUREAU OF TRAFFIC OPERATIONS/ELECTRICAL FIELD OFFICE TO CONFIRM EXISTING AND PROPOSED FIBER ASSIGNMENTS ALONG ALL PATHS.
- CONNECT THE NEW FIBER OPTIC AND POWER SERVICE CABLES TO THE EXISTING CCTV EQUIPMENT. THIS WORK WILL BE COVERED UNDER THE "RELOCATE EXISTING CCTV CAMERA" PAY ITEM.

(1) 279 FT. CONDUIT ATTACHED TO STRUCTURE, 3" DIA.,
 PVC COATED GALVANIZED STEEL
 (9) 279 FT. ELECTRIC CABLE IN CONDUIT, LEAD-IN,
 NO. 18 4/C, TWISTED, SHIELDED
 (2) 279 FT. CONDUIT ATTACHED TO STRUCTURE, 2" DIA.,
 PVC COATED GALVANIZED STEEL
 (1) 279 FT. FIBER OPTIC CABLE 96 FIBERS, SINGLE MODE
 (1) 279 FT. ELECTRIC CABLE ASSEMBLY IN CONDUIT,
 600V (XLP-TYPE TC) 2/C NO. 6 AND NO. 8

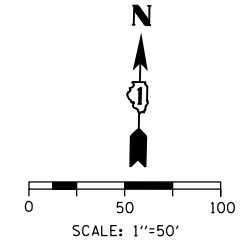

ITS-03

FILE PATH = p:\1617479-PM\INT\pccom\line\local\AECOM\0502_006_CAD\006_Roadway\Sheets\60X78_Contract\016078-sht-ITS-03



D16078-sht-ITS-03
 USER NAME = dshevoz
 PLOT SCALE = 100.0000' / in.
 PLOT DATE = 4/27/2016

DESIGNED - GWS	REVISED -
DRAWN - CAM	REVISED -
CHECKED - JDG	REVISED -
DATE - 3/18/2016	REVISED -

**STATE OF ILLINOIS
 DEPARTMENT OF TRANSPORTATION**

**PROPOSED ITS PLAN
 WB I-290 OVER I-90/94 AND WB CONGRESS PARKWAY**
 SCALE: 1"=50' SHEET 3 OF 20 SHEETS STA. 5206+25 TO STA. 5221+50

F.A.I. RTE.	SECTION	COUNTY	TOTAL SHEETS	SHEET NO.
90/94/290	2014-004R&B	COOK	706	168
CONTRACT NO. 60X78				
ILLINOIS FED. AID PROJECT				

NOTES:

1. SPLICE NEW 96 SMF CABLE IN EXISTING SPLICE BOX MOUNTED ON WALL. RUN NEW CONDUIT FROM FO SPLICE BOX THROUGH DRILLED HOLE IN THE RETAINING WALL. LAY CONDUIT ON GROUND FROM RETAINING WALL TO THE CENTER OF THE STRUCTURE. ATTACH CONDUIT TO THE BEAM UNDER THE EXISTING I-290 WB MEDIAN WALL. CONDUIT TO BE ATTACHED TO THE STRUCTURE UP TO THE NEW MEDIAN WALL AT PIER C12 WHERE THE CONDUIT WILL ATTACH TO A JUNCTION BOX MOUNTED UNDER THE DECK. 96 SMF CABLE WILL THEN GO INTO THE TYPE J JUNCTION BOX EMBEDDED IN THE NEW I-290 WB MEDIAN WALL.
2. DROP OUT CONDUITS FROM BOTTOM OF JUNCTION BOX EMBEDDED IN WALL AND CONNECT TO THE 2-2" G.S. CONDUITS ATTACHED TO STRUCTURE. SEE DROP-OUT AT PIER DETAIL ON SHEET ITS-13.
3. INDUCTION LOOPS (6 FT. DIA.) TO BE CENTERED IN MARKED I-290 WB TRAVEL LANES.
4. INSTALL 10"x8"x4" JUNCTION BOXES ATTACHED TO STRUCTURE UNDER EACH LOOP.
5. ALL WORK SHOWN ON THIS SHEET MUST BE COORDINATED WITH THIS CONTRACT'S CONSTRUCTION WORK AND STAGING.
6. CONDUIT AND CABLES FROM EXISTING LOOPS TO CONNECT TO 10"x8"x4" JUNCTION BOX ATS WHICH HAS CONDUITS AND CABLES FROM NEW PREFORMED LOOPS. THIS JB ATTACHES TO TYPE J EMBEDDED JUNCTION BOX USING A 2" GALVANIZED STEEL CONDUIT AND ONE OF THE 2" DROP-OUTS.
7. SEE ITS DETAIL D ON SHEET ITS-09 FOR JUNCTION BOX AND CONDUIT ATTACHMENTS TO STRUCTURE.
8. ALL NEW FIBER OPTIC CABLES ARE TO MATCH EXISTING FIBER/SPLICE/TERMINATIONS.
9. THE LOCATIONS OF THE ITS EQUIPMENT SHOWN ON THE PLAN ARE APPROXIMATIONS. THE FINAL INSTALLATION LOCATIONS OF THE ITS EQUIPMENT SHALL BE STAKED IN THE FIELD AND APPROVED BY THE ENGINEER PRIOR TO BEGINNING ANY WORK TO ENSURE THAT THERE ARE NO CONFLICTS WITH EXISTING/PROPOSED UTILITIES AND WORK PERFORMED BY OTHER DISCIPLINES.

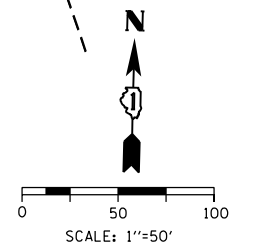
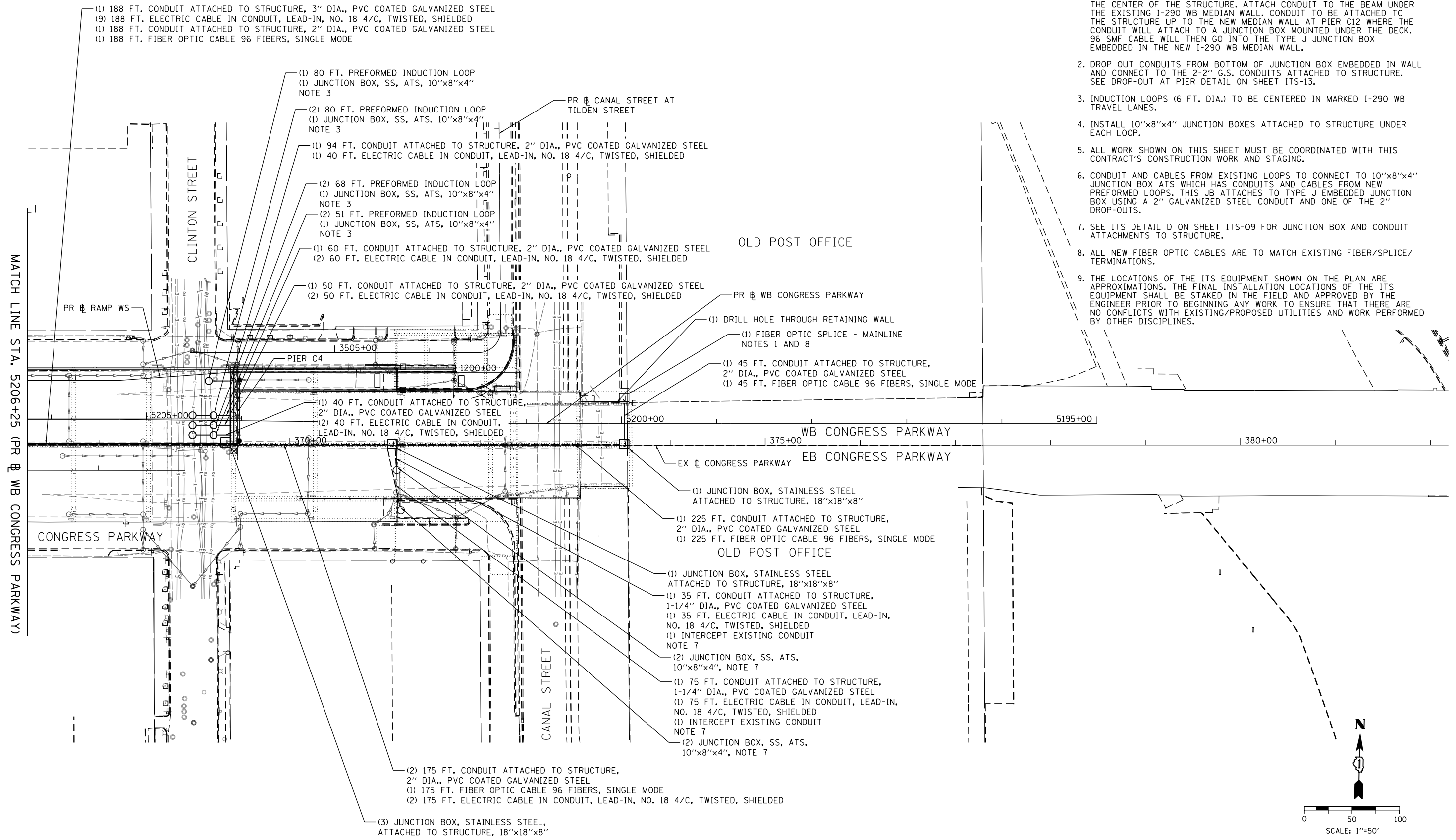

ITS-04

FILE PATH = p:\61749-PMINT\recomon\line\local\AECOM_D502_NA\Documents\01_Americas\T\engpr\station\60269938_Circle\Phase_11\000_CAD\006_Roadway\Sheets\60X78_Contract\0160X78-sht-ITS-04



D160X78-sht-ITS-04	DESIGNED - GWS	REVISED -
USER NAME = myersc	DRAWN - CAM	REVISED -
PLOT SCALE = 100.0000' / in.	CHECKED - JDC	REVISED -
PLOT DATE = 3/17/2016	DATE - 3/18/2016	REVISED -

STATE OF ILLINOIS
DEPARTMENT OF TRANSPORTATION

PROPOSED ITS PLAN	
WB I-290 OVER I-90/94 AND WB CONGRESS PARKWAY	
SCALE: 1"=50'	SHEET 4 OF 20 SHEETS
STA. 5195+00	TO STA. 5206+25

F.A.I. RTE.	SECTION	COUNTY	TOTAL SHEETS	SHEET NO.
90/94/290	2014-004R&B	COOK	706	169
CONTRACT NO. 60X78				
ILLINOIS FED. AID PROJECT				

FILE PATH = p:\617479-PMINT\pccommon\line\loc\1\AECOM\0592_NA\Documents\01_Americas\IT\engor\station\60269938 Circle\Phase_11\000_CAD\006_Roadway\Sheets\60x78_Contract\0160x78-sht-ITS-05

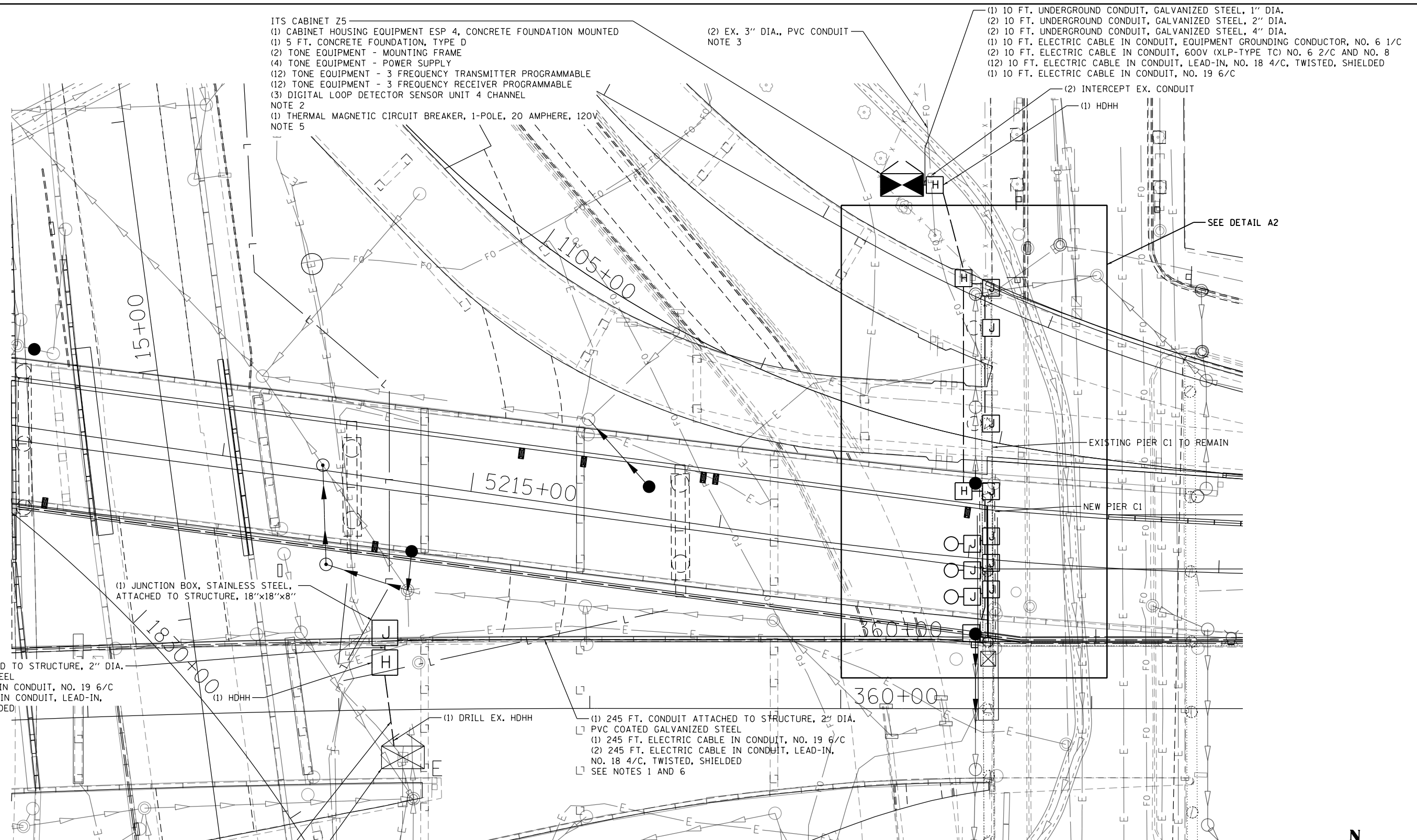

ITS CABINET Z5
 (1) CABINET HOUSING EQUIPMENT ESP 4, CONCRETE FOUNDATION MOUNTED
 (1) 5 FT. CONCRETE FOUNDATION, TYPE D
 (2) TONE EQUIPMENT - MOUNTING FRAME
 (4) TONE EQUIPMENT - POWER SUPPLY
 (12) TONE EQUIPMENT - 3 FREQUENCY TRANSMITTER PROGRAMMABLE
 (12) TONE EQUIPMENT - 3 FREQUENCY RECEIVER PROGRAMMABLE
 (3) DIGITAL LOOP DETECTOR SENSOR UNIT 4 CHANNEL
 NOTE 2
 (1) THERMAL MAGNETIC CIRCUIT BREAKER, 1-POLE, 20 AMPHERE, 120V
 NOTE 5

(2) EX. 3" DIA., PVC CONDUIT
 NOTE 3

(1) 10 FT. UNDERGROUND CONDUIT, GALVANIZED STEEL, 1" DIA.
 (2) 10 FT. UNDERGROUND CONDUIT, GALVANIZED STEEL, 2" DIA.
 (2) 10 FT. UNDERGROUND CONDUIT, GALVANIZED STEEL, 4" DIA.
 (1) 10 FT. ELECTRIC CABLE IN CONDUIT, EQUIPMENT GROUNDING CONDUCTOR, NO. 6 1/C
 (2) 10 FT. ELECTRIC CABLE IN CONDUIT, 600V (XLP-TYPE TC) NO. 6 2/C AND NO. 8
 (12) 10 FT. ELECTRIC CABLE IN CONDUIT, LEAD-IN, NO. 18 4/C, TWISTED, SHIELDED
 (1) 10 FT. ELECTRIC CABLE IN CONDUIT, NO. 19 6/C

(2) INTERCEPT EX. CONDUIT

(1) HDHH

SEE DETAIL A2

EXISTING PIER C1 TO REMAIN

NEW PIER C1

(1) JUNCTION BOX, STAINLESS STEEL,
 ATTACHED TO STRUCTURE, 18"x18"x8"

(1) 40 FT. CONDUIT ATTACHED TO STRUCTURE, 2" DIA.
 PVC COATED GALVANIZED STEEL
 (1) 40 FT. ELECTRIC CABLE IN CONDUIT, NO. 19 6/C
 (2) 40 FT. ELECTRIC CABLE IN CONDUIT, LEAD-IN,
 NO. 18 4/C, TWISTED, SHIELDED

(1) HDHH

(1) DRILL EX. HDHH

(1) 245 FT. CONDUIT ATTACHED TO STRUCTURE, 2" DIA.
 PVC COATED GALVANIZED STEEL
 (1) 245 FT. ELECTRIC CABLE IN CONDUIT, NO. 19 6/C
 (2) 245 FT. ELECTRIC CABLE IN CONDUIT, LEAD-IN,
 NO. 18 4/C, TWISTED, SHIELDED
 SEE NOTES 1 AND 6

(1) 40 FT. UNDERGROUND CONDUIT, GALVANIZED STEEL, 2" DIA.
 (1) 40 FT. ELECTRIC CABLE IN CONDUIT, NO. 19 6/C
 (2) 40 FT. ELECTRIC CABLE IN CONDUIT, LEAD-IN, NO. 18 4/C,
 TWISTED, SHIELDED
 NOTE 3

EX. CABINET Z4
 (2) TONE EQUIPMENT - 3 FREQUENCY TRANSMITTER PROGRAMMABLE
 (2) TONE EQUIPMENT - 3 FREQUENCY RECEIVER PROGRAMMABLE
 (1) DIGITAL LOOP DETECTOR SENSOR UNIT 4 CHANNEL
 (2) LIGHTNING PROTECTION FOR INDUCTION LOOP DETECTOR
 NOTE 2

NOTES:

- SEE DETAIL PIER C1 ON SHEET ITS-08 FOR JUNCTION BOX AND CONDUIT LOCATIONS.
- INTEGRATION OF LOOP DETECTOR STATIONS SHALL BE PAID UNDER THE "ATMS SYSTEM INTEGRATION" PAY ITEM.
- QUANTITY ON SHEET ITS-01.
- SEE CONDUIT ASSIGNMENTS ON SHEETS ITS-06 AND ITS-08.
- POWER TO ITS CABINET Z5 WILL BE FROM PS 5. POWER TO CCTV AT JEFFERSON ST. THROUGH CIRCUIT BREAKER IN CABINET Z5.
- THE (2) NO. 18 4/C LEAD-INS AND THE NO. 19 6/C WILL USE ONE 2" CONDUIT FROM A JUNCTION BOX ATTACHED TO THE NEW PIER C1 STRUCTURE.
- THE LOCATIONS OF THE ITS EQUIPMENT SHOWN ON THE PLAN ARE APPROXIMATIONS. THE FINAL INSTALLATION LOCATIONS OF THE ITS EQUIPMENT SHALL BE STAKED IN THE FIELD AND APPROVED BY THE ENGINEER PRIOR TO BEGINNING ANY WORK TO ENSURE THAT THERE ARE NO CONFLICTS WITH EXISTING/PROPOSED UTILITIES AND WORK PERFORMED BY OTHER DISCIPLINES.

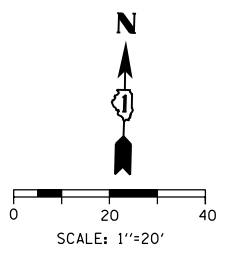

D160x78-sht-ITS-05	DESIGNED - GWS	REVISED -
USER NAME = myersc	DRAWN - CAM	REVISED -
PLOT SCALE = 40.0000' / in.	CHECKED - JDG	REVISED -
PLOT DATE = 3/17/2016	DATE - 3/18/2016	REVISED -

STATE OF ILLINOIS
 DEPARTMENT OF TRANSPORTATION

ITS DETAIL A
 WB I-290 OVER I-90/94 AND WB CONGRESS PARKWAY
 SCALE: 1"=20' SHEET 5 OF 20 SHEETS STA. TO STA.

F.A.I. RTE. 90/94/290	SECTION 2014-004R&B	COUNTY COOK	TOTAL SHEETS 706	SHEET NO. 170
CONTRACT NO. 60X78				
ILLINOIS FED. AID PROJECT				

ITS-05

FILE PATH = p:\617479-PM\INT\ascom\line\local\IPE\CDM_D502_MIA\Documents\01\Americas\T\engp\station\602695938_Circle\Phase_11\000_CAD\006_Roadway\Sheets\60x78_Contract\0160x78-sht-ITS-06

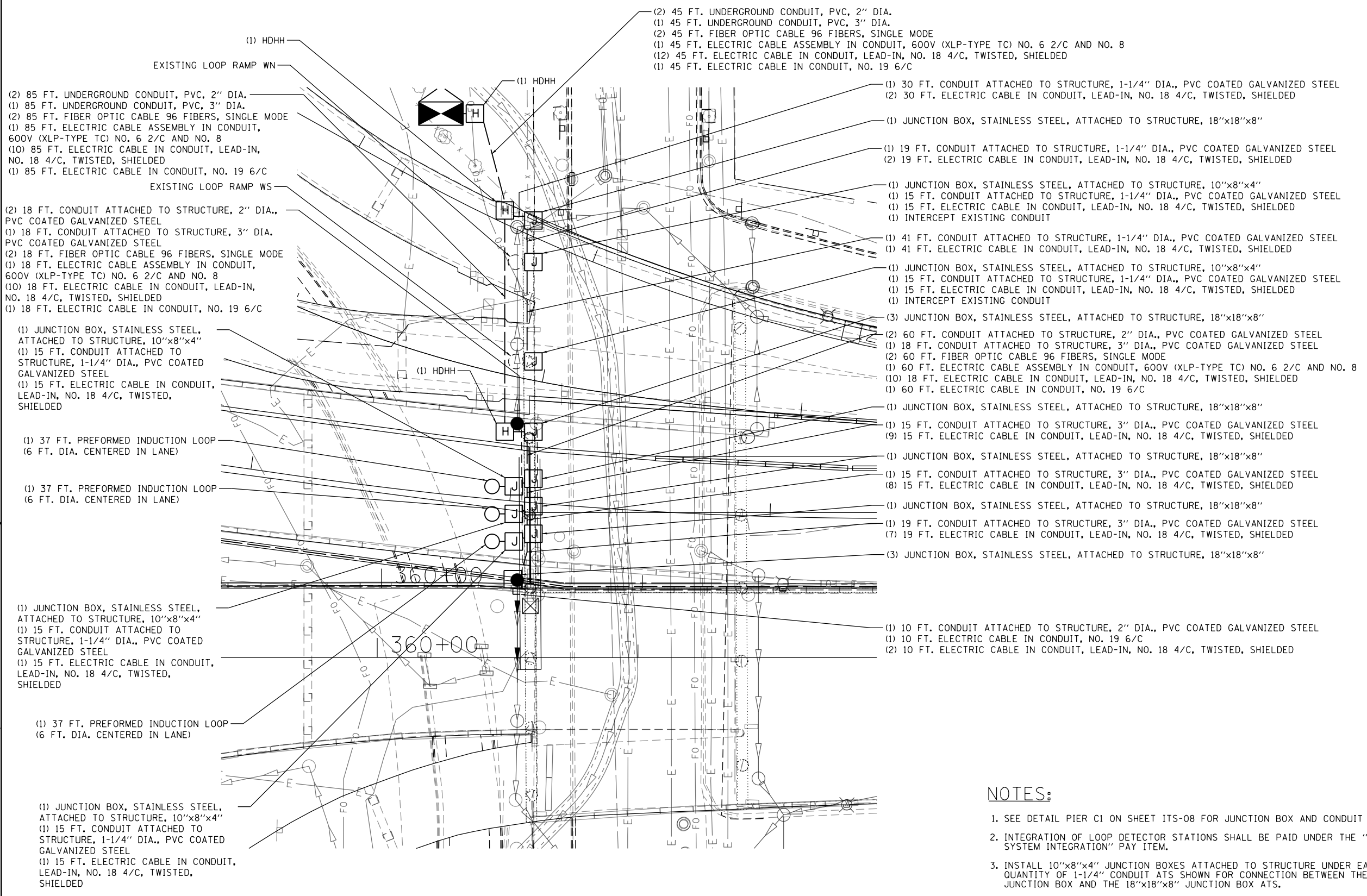

(2) 85 FT. UNDERGROUND CONDUIT, PVC, 2" DIA.
 (1) 85 FT. UNDERGROUND CONDUIT, PVC, 3" DIA.
 (2) 85 FT. FIBER OPTIC CABLE 96 FIBERS, SINGLE MODE
 (1) 85 FT. ELECTRIC CABLE ASSEMBLY IN CONDUIT, 600V (XLP-TYPE TC) NO. 6 2/C AND NO. 8
 (10) 85 FT. ELECTRIC CABLE IN CONDUIT, LEAD-IN, NO. 18 4/C, TWISTED, SHIELDED
 (1) 85 FT. ELECTRIC CABLE IN CONDUIT, NO. 19 6/C

(2) 18 FT. CONDUIT ATTACHED TO STRUCTURE, 2" DIA., PVC COATED GALVANIZED STEEL
 (1) 18 FT. CONDUIT ATTACHED TO STRUCTURE, 3" DIA. PVC COATED GALVANIZED STEEL
 (2) 18 FT. FIBER OPTIC CABLE 96 FIBERS, SINGLE MODE
 (1) 18 FT. ELECTRIC CABLE ASSEMBLY IN CONDUIT, 600V (XLP-TYPE TC) NO. 6 2/C AND NO. 8
 (10) 18 FT. ELECTRIC CABLE IN CONDUIT, LEAD-IN, NO. 18 4/C, TWISTED, SHIELDED
 (1) 18 FT. ELECTRIC CABLE IN CONDUIT, NO. 19 6/C

(1) JUNCTION BOX, STAINLESS STEEL, ATTACHED TO STRUCTURE, 10"x8"x4"
 (1) 15 FT. CONDUIT ATTACHED TO STRUCTURE, 1-1/4" DIA., PVC COATED GALVANIZED STEEL
 (1) 15 FT. ELECTRIC CABLE IN CONDUIT, LEAD-IN, NO. 18 4/C, TWISTED, SHIELDED

(1) 37 FT. PREFORMED INDUCTION LOOP (6 FT. DIA. CENTERED IN LANE)
 (1) 37 FT. PREFORMED INDUCTION LOOP (6 FT. DIA. CENTERED IN LANE)

(1) JUNCTION BOX, STAINLESS STEEL, ATTACHED TO STRUCTURE, 10"x8"x4"
 (1) 15 FT. CONDUIT ATTACHED TO STRUCTURE, 1-1/4" DIA., PVC COATED GALVANIZED STEEL
 (1) 15 FT. ELECTRIC CABLE IN CONDUIT, LEAD-IN, NO. 18 4/C, TWISTED, SHIELDED

(1) 37 FT. PREFORMED INDUCTION LOOP (6 FT. DIA. CENTERED IN LANE)

(1) JUNCTION BOX, STAINLESS STEEL, ATTACHED TO STRUCTURE, 10"x8"x4"
 (1) 15 FT. CONDUIT ATTACHED TO STRUCTURE, 1-1/4" DIA., PVC COATED GALVANIZED STEEL
 (1) 15 FT. ELECTRIC CABLE IN CONDUIT, LEAD-IN, NO. 18 4/C, TWISTED, SHIELDED

(2) 45 FT. UNDERGROUND CONDUIT, PVC, 2" DIA.
 (1) 45 FT. UNDERGROUND CONDUIT, PVC, 3" DIA.
 (2) 45 FT. FIBER OPTIC CABLE 96 FIBERS, SINGLE MODE
 (1) 45 FT. ELECTRIC CABLE ASSEMBLY IN CONDUIT, 600V (XLP-TYPE TC) NO. 6 2/C AND NO. 8
 (12) 45 FT. ELECTRIC CABLE IN CONDUIT, LEAD-IN, NO. 18 4/C, TWISTED, SHIELDED
 (1) 45 FT. ELECTRIC CABLE IN CONDUIT, NO. 19 6/C

(1) 30 FT. CONDUIT ATTACHED TO STRUCTURE, 1-1/4" DIA., PVC COATED GALVANIZED STEEL
 (2) 30 FT. ELECTRIC CABLE IN CONDUIT, LEAD-IN, NO. 18 4/C, TWISTED, SHIELDED

(1) JUNCTION BOX, STAINLESS STEEL, ATTACHED TO STRUCTURE, 18"x18"x8"

(1) 19 FT. CONDUIT ATTACHED TO STRUCTURE, 1-1/4" DIA., PVC COATED GALVANIZED STEEL
 (2) 19 FT. ELECTRIC CABLE IN CONDUIT, LEAD-IN, NO. 18 4/C, TWISTED, SHIELDED

(1) JUNCTION BOX, STAINLESS STEEL, ATTACHED TO STRUCTURE, 10"x8"x4"
 (1) 15 FT. CONDUIT ATTACHED TO STRUCTURE, 1-1/4" DIA., PVC COATED GALVANIZED STEEL
 (1) 15 FT. ELECTRIC CABLE IN CONDUIT, LEAD-IN, NO. 18 4/C, TWISTED, SHIELDED
 (1) INTERCEPT EXISTING CONDUIT

(1) 41 FT. CONDUIT ATTACHED TO STRUCTURE, 1-1/4" DIA., PVC COATED GALVANIZED STEEL
 (1) 41 FT. ELECTRIC CABLE IN CONDUIT, LEAD-IN, NO. 18 4/C, TWISTED, SHIELDED

(1) JUNCTION BOX, STAINLESS STEEL, ATTACHED TO STRUCTURE, 10"x8"x4"
 (1) 15 FT. CONDUIT ATTACHED TO STRUCTURE, 1-1/4" DIA., PVC COATED GALVANIZED STEEL
 (1) 15 FT. ELECTRIC CABLE IN CONDUIT, LEAD-IN, NO. 18 4/C, TWISTED, SHIELDED
 (1) INTERCEPT EXISTING CONDUIT

(3) JUNCTION BOX, STAINLESS STEEL, ATTACHED TO STRUCTURE, 18"x18"x8"

(2) 60 FT. CONDUIT ATTACHED TO STRUCTURE, 2" DIA., PVC COATED GALVANIZED STEEL
 (1) 18 FT. CONDUIT ATTACHED TO STRUCTURE, 3" DIA., PVC COATED GALVANIZED STEEL
 (2) 60 FT. FIBER OPTIC CABLE 96 FIBERS, SINGLE MODE
 (1) 60 FT. ELECTRIC CABLE ASSEMBLY IN CONDUIT, 600V (XLP-TYPE TC) NO. 6 2/C AND NO. 8
 (10) 18 FT. ELECTRIC CABLE IN CONDUIT, LEAD-IN, NO. 18 4/C, TWISTED, SHIELDED
 (1) 60 FT. ELECTRIC CABLE IN CONDUIT, NO. 19 6/C

(1) JUNCTION BOX, STAINLESS STEEL, ATTACHED TO STRUCTURE, 18"x18"x8"

(1) 15 FT. CONDUIT ATTACHED TO STRUCTURE, 3" DIA., PVC COATED GALVANIZED STEEL
 (9) 15 FT. ELECTRIC CABLE IN CONDUIT, LEAD-IN, NO. 18 4/C, TWISTED, SHIELDED

(1) JUNCTION BOX, STAINLESS STEEL, ATTACHED TO STRUCTURE, 18"x18"x8"

(1) 15 FT. CONDUIT ATTACHED TO STRUCTURE, 3" DIA., PVC COATED GALVANIZED STEEL
 (8) 15 FT. ELECTRIC CABLE IN CONDUIT, LEAD-IN, NO. 18 4/C, TWISTED, SHIELDED

(1) JUNCTION BOX, STAINLESS STEEL, ATTACHED TO STRUCTURE, 18"x18"x8"

(1) 19 FT. CONDUIT ATTACHED TO STRUCTURE, 3" DIA., PVC COATED GALVANIZED STEEL
 (7) 19 FT. ELECTRIC CABLE IN CONDUIT, LEAD-IN, NO. 18 4/C, TWISTED, SHIELDED

(3) JUNCTION BOX, STAINLESS STEEL, ATTACHED TO STRUCTURE, 18"x18"x8"

(1) 10 FT. CONDUIT ATTACHED TO STRUCTURE, 2" DIA., PVC COATED GALVANIZED STEEL
 (1) 10 FT. ELECTRIC CABLE IN CONDUIT, NO. 19 6/C
 (2) 10 FT. ELECTRIC CABLE IN CONDUIT, LEAD-IN, NO. 18 4/C, TWISTED, SHIELDED

NOTES:

- SEE DETAIL PIER C1 ON SHEET ITS-08 FOR JUNCTION BOX AND CONDUIT LOCATIONS.
- INTEGRATION OF LOOP DETECTOR STATIONS SHALL BE PAID UNDER THE "ATMS SYSTEM INTEGRATION" PAY ITEM.
- INSTALL 10"x8"x4" JUNCTION BOXES ATTACHED TO STRUCTURE UNDER EACH LOOP. QUANTITY OF 1-1/4" CONDUIT ATTS SHOWN FOR CONNECTION BETWEEN THE 10"x8"x4" JUNCTION BOX AND THE 18"x18"x8" JUNCTION BOX ATTS.
- ALL WORK SHOWN ON THIS SHEET MUST BE COORDINATED WITH THIS CONTRACT'S CONSTRUCTION WORK AND STAGING.
- THE LOCATIONS OF THE ITS EQUIPMENT SHOWN ON THE PLAN ARE APPROXIMATIONS. THE FINAL INSTALLATION LOCATIONS OF THE ITS EQUIPMENT SHALL BE STAKED IN THE FIELD AND APPROVED BY THE ENGINEER PRIOR TO BEGINNING ANY WORK TO ENSURE THAT THERE ARE NO CONFLICTS WITH EXISTING/PROPOSED UTILITIES AND WORK PERFORMED BY OTHER DISCIPLINES.

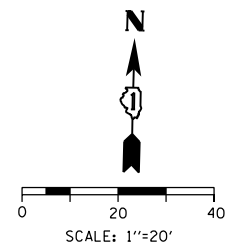

ITS-06



D160x78-sht-ITS-06	DESIGNED - GWS	REVISED -
USER NAME = myersc	DRAWN - CAM	REVISED -
PLOT SCALE = 40.0000' / in.	CHECKED - JDG	REVISED -
PLOT DATE = 3/17/2016	DATE - 3/18/2016	REVISED -

**STATE OF ILLINOIS
 DEPARTMENT OF TRANSPORTATION**

ITS DETAIL A2	
WB I-290 OVER I-90/94 AND WB CONGRESS PARKWAY	
SCALE: 1"=20'	SHEET 6 OF 20 SHEETS STA. TO STA.

F.A.I. RTE.	SECTION	COUNTY	TOTAL SHEETS	SHEET NO.
90/94/290	2014-004R&B	COOK	706	171
CONTRACT NO. 60X78				
ILLINOIS FED. AID PROJECT				

CONDUIT ATTACHED TO STRUCTURE, 2" DIA.,
PVC COATED GALVANIZED STEEL
FIBER OPTIC CABLE 96 FIBERS, SINGLE-MODE

JUNCTION BOX, STAINLESS STEEL,
ATTACHED TO STRUCTURE, 18"x18"x8"
FIBER OPTIC SPLICE - LATERAL
NOTE 4

PROPOSED SIGN TRUSS

CONDUIT ATTACHED TO STRUCTURE, 2" DIA.,
PVC COATED GALVANIZED STEEL
FIBER OPTIC CABLE 12 FIBERS, SINGLE-MODE

CONDUIT ATTACHED TO STRUCTURE, 2" DIA.,
PVC COATED GALVANIZED STEEL
ELECTRIC CABLE ASSEMBLY IN CONDUIT,
600V (XLP-TYPE TC) NO. 6 2/C AND NO. 8

JUNCTION BOX, STAINLESS STEEL,
ATTACHED TO STRUCTURE, 18"x18"x8"

CONDUIT ATTACHED TO STRUCTURE, 2" DIA.,
PVC COATED GALVANIZED STEEL
ELECTRIC CABLE ASSEMBLY IN CONDUIT,
600V (XLP-TYPE TC) NO. 6 2/C AND NO. 8
NOTE 4

CONDUIT ATTACHED TO STRUCTURE, 2" DIA.,
PVC COATED GALVANIZED STEEL
ETHERNET CABLES TO CCTV CAMERAS

EX. CCTV EQUIPMENT CABINET
ATTACHED TO STRUCTURE

PIER (C6) WEST OF S. JEFFERSON STREET (LOOKING WEST)

NOTES:

1. SPLICE THE 12 SMF CABLE FROM THE CCTV EQUIPMENT CABINET TO THE 96 SMF CABLE FROM THE JUNCTION BOX ATTACHED TO THE WEST SIDE OF THE POST OFFICE. THE 96 SMF CABLE IS ATTACHED THE INSIDE OF THE BEAM AND WILL GO INTO THE JUNCTION BOX FOR THE LATERAL SPLICE AND THEN CONTINUE TO THE WEST TO PIER C1.
2. THE 2" CONDUIT FOR THE CCTV EQUIPMENT POWER SERVICE CABLES IS TO BE ATTACHED TO THE INSIDE OF THE BEAM AND CONTINUE TO THE WEST TO PIER C1.
3. THE LOCATIONS OF THE ITS EQUIPMENT SHOWN ON THE PLAN ARE APPROXIMATIONS. THE FINAL INSTALLATION LOCATIONS OF THE ITS EQUIPMENT SHALL BE STAKED IN THE FIELD AND APPROVED BY THE ENGINEER PRIOR TO BEGINNING ANY WORK TO ENSURE THAT THERE ARE NO CONFLICTS WITH EXISTING/PROPOSED UTILITIES AND WORK PERFORMED BY OTHER DISCIPLINES.
4. INSTALL NEW FIBER OPTIC AND ELECTRIC CABLES IN NEW CONDUITS AND CONNECT TO EXISTING CCTV CAMERA EQUIPMENT. THIS WORK WILL NOT BE PAID FOR SEPARATELY BUT WILL BE INCLUDED IN THE "RELOCATE EXISTING CCTV CAMERA" PAY ITEM.
5. USE EXISTING FIBER ASSIGNMENTS FOR SPLICES AND CONNECTIONS.

FILE PATH = p:\61779-PMINT\ecomon\line\local\AECOM\0902_NA\Documents\01_Americas\T\engor\station\60269438_Circle\Phase_1\1000_CAD\006_Roadway\Sheets\60X78_Contract\0160X78-sht-ITS-07

ITS-07



D160X78-sht-ITS-07	DESIGNED - GWS	REVISED -
USER NAME = dshevoz	DRAWN - CAM	REVISED -
PLOT SCALE = 40.0000' / in.	CHECKED - JDG	REVISED -
PLOT DATE = 4/27/2016	DATE - 3/18/2016	REVISED -

**STATE OF ILLINOIS
DEPARTMENT OF TRANSPORTATION**

**ITS DETAIL B - CCTV AT JEFFERSON STREET
WB I-290 OVER I-90/94 AND WB CONGRESS PARKWAY**

SCALE: NO SCALE SHEET 7 OF 20 SHEETS STA. TO STA.

F.A.I. RTE.	SECTION	COUNTY	TOTAL SHEETS	SHEET NO.
90/94/290	2014-004R&B	COOK	706	172
CONTRACT NO. 60X78				
ILLINOIS FED. AID PROJECT				

FILE PATH = p:\61779-PMINT\pccommon\loc\p\AECOM\0902_NA\Documents\01_Americas\Tran\engortation\602694938_Circle\Phase_11\000_CAD\006_Roadway\Sheets\60X78_Contract\018978-sht-ITS-08

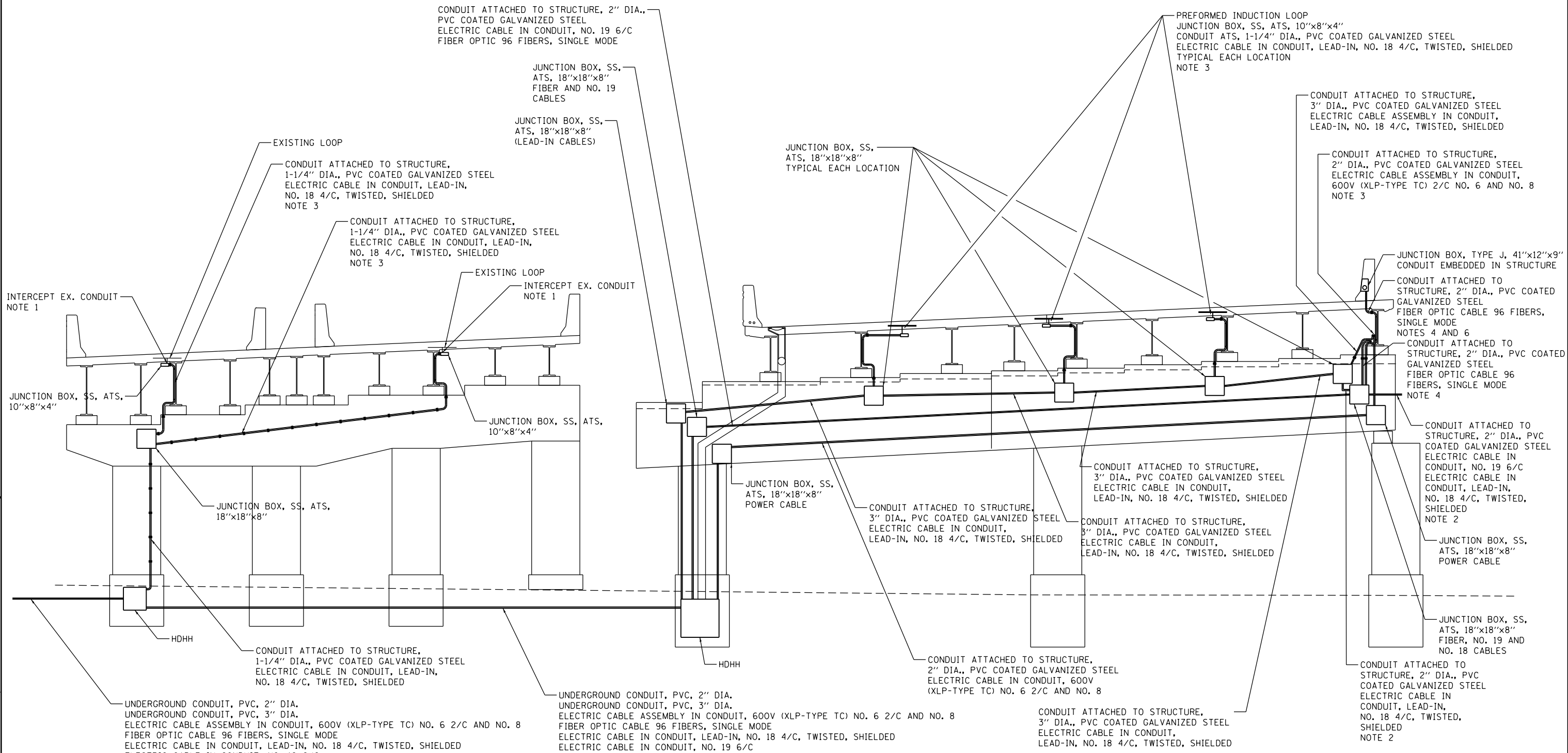

**PIER C1
(LOOKING EAST)**

- NOTES:**
- INTERCEPT EXISTING LOOP WIRE/CONDUIT UNDER DECK. SPLICE EXISTING NO. 14 1 PR TO NO. 18 4/C IN 10"x8"x4" JUNCTION BOX MOUNTED UNDER DECK.
 - THE LOOP LEAD-IN CABLES FROM THE EB I-290 STRUCTURE ARE TO BE ROUTED TO ITS CABINET Z4. CONNECT A CONDUIT BETWEEN THE JB ATS FOR THE LOOP CABLES TO THE JB ATS FOR THE FIBER OPTIC AND NO. 19 CABLES. THE 2 LOOP LEAD-IN CABLES AND THE NO. 19 6/C CABLE WILL EXIT THE JB ATS TO THE SOUTH ATTACHED TO THE PIER AND THEN WILL BE ATTACHED TO THE EB I-290 STRUCTURE.
 - SEE ITS DETAILS, SHEET ITS-13, CONDUIT ATTACHED TO PIER INSTALLATION DETAIL.
 - THE ELECTRIC CABLE IN CONDUIT, NO. 6 2/C AND NO. 8 GOES FROM ITS CABINET Z5 TO THE CAMERA EQUIPMENT JUNCTION BOX ATS AT PIER C6. ONE 96 FIBER OPTIC CABLE GOES FROM THE JUNCTION BOX ATS AT THE POST OFFICE TO PUMP STATION 5. THE OTHER 96 FIBER OPTIC CABLE GOES FROM PUMP STATION 5 TO THE COMMUNICATIONS HUT.
 - ALL WORK SHOWN ON THIS SHEET MUST BE COORDINATED WITH THIS CONTRACT'S CONSTRUCTION WORK AND STAGING.
 - CONNECT CONDUIT WITH (1) FIBER OPTIC CABLE 96 FIBERS, SINGLE MODE, TO THE DROP-OUTS FROM THE EMBEDDED JUNCTION BOX TYPE J IN THE MEDIAN BARRIER.
 - ALL QUANTITIES SHOWN ON SHEET ITS-06.
 - THE LOCATIONS OF THE ITS EQUIPMENT SHOWN ON THE PLAN ARE APPROXIMATIONS. THE FINAL INSTALLATION LOCATIONS OF THE ITS EQUIPMENT SHALL BE STAKED IN THE FIELD AND APPROVED BY THE ENGINEER PRIOR TO BEGINNING ANY WORK TO ENSURE THAT THERE ARE NO CONFLICTS WITH EXISTING/PROPOSED UTILITIES AND WORK PERFORMED BY OTHER DISCIPLINES.

ITS-08



D160X78-sht-ITS-08
 USER NAME = myersc
 PLOT SCALE = 40.0000' / in.
 PLOT DATE = 3/17/2016

DESIGNED - GWS
 DRAWN - CAM
 CHECKED - JDG
 DATE - 3/18/2016

REVISED -
 REVISED -
 REVISED -
 REVISED -

**STATE OF ILLINOIS
DEPARTMENT OF TRANSPORTATION**

**ITS DETAIL C
WB I-290 OVER I-90/94 AND WB CONGRESS PARKWAY**

SCALE: NO SCALE SHEET 8 OF 20 SHEETS STA. TO STA.

F.A.I. RTE. 90/94/290	SECTION 2014-004R&B	COUNTY COOK	TOTAL SHEETS 706	SHEET NO. 173
CONTRACT NO. 60X78				
ILLINOIS FED. AID PROJECT				

FILE PATH = p:\61779-PMINT.aecom\line\local\AECOM_D902_NA\Documents\01_Americas\T_engg\station\60269438_Circle\Phase_1\1000_CAD\006_Roadway\Sheets\60X78_Contract\0160X78-sht-ITS-09

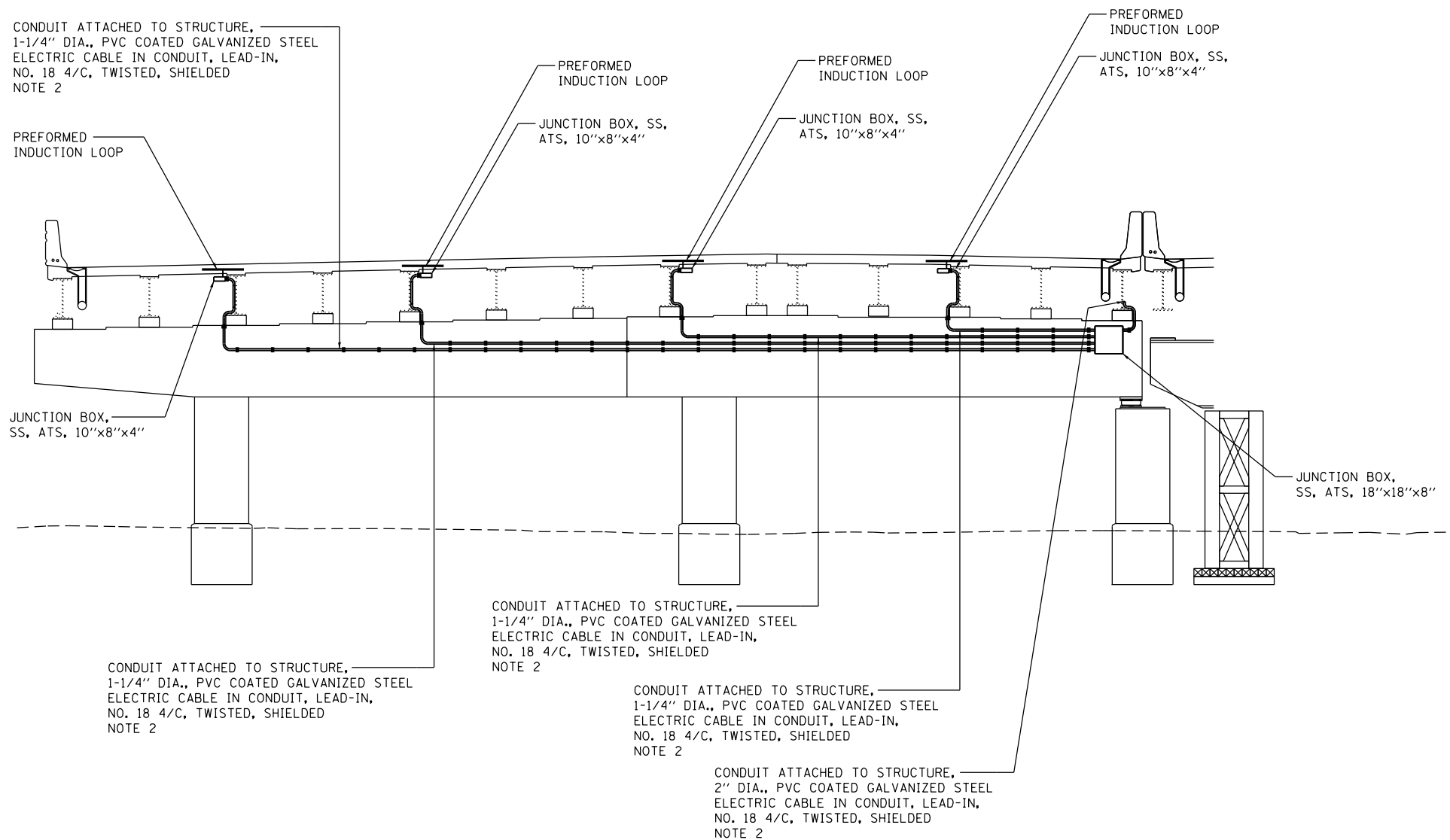

**PIER C12
(LOOKING EAST)**

NOTES:

1. INTERCEPT EXISTING LOOP WIRE/CONDUIT UNDER DECK. SPLICE EXISTING NO. 14 1 PR TO NO. 18 4/C IN 10"x8"x4" JUNCTION BOX MOUNTED UNDER DECK.
2. SEE ITS DETAILS, ITS-13, CONDUIT ATTACHED TO PIER INSTALLATION DETAIL.
3. ALL WORK SHOWN ON THIS SHEET MUST BE COORDINATED WITH THIS CONTRACT'S CONSTRUCTION WORK AND STAGING.
4. THE EXISTING LOOPS ON I-290 EB SHALL BE ROUTED AND CONNECTED TO EXISTING SURVEILLANCE CABINET Z4.
5. THE LOCATIONS OF THE ITS EQUIPMENT SHOWN ON THE PLAN ARE APPROXIMATIONS. THE FINAL INSTALLATION LOCATIONS OF THE ITS EQUIPMENT SHALL BE STAKED IN THE FIELD AND APPROVED BY THE ENGINEER PRIOR TO BEGINNING ANY WORK TO ENSURE THAT THERE ARE NO CONFLICTS WITH EXISTING/PROPOSED UTILITIES AND WORK PERFORMED BY OTHER DISCIPLINES.

ITS-09



D160X78-sht-ITS-09	DESIGNED - GWS	REVISED -
USER NAME = myersc	DRAWN - CAM	REVISED -
PLOT SCALE = 40.0000' / in.	CHECKED - JDG	REVISED -
PLOT DATE = 3/17/2016	DATE - 3/18/2016	REVISED -

**STATE OF ILLINOIS
DEPARTMENT OF TRANSPORTATION**

**ITS DETAIL D
WB I-290 OVER I-90/94 AND WB CONGRESS PARKWAY**

SCALE: NO SCALE SHEET 9 OF 20 SHEETS STA. TO STA.

F.A.I. RTE.	SECTION	COUNTY	TOTAL SHEETS	SHEET NO.
90/94/290	2014-004R&B	COOK	706	174
CONTRACT NO. 60X78				
ILLINOIS FED. AID PROJECT				

FILE PATH = p:\61779-PMINT.aecom\line\local\AECOM_D902_NA\Documents\01_Americas\T_engg\location\60269938_Circle\Phase_1\1000_CAD\006_Roadway\Sheets\60X78_Contract\0160X78-sht-ITS-09A

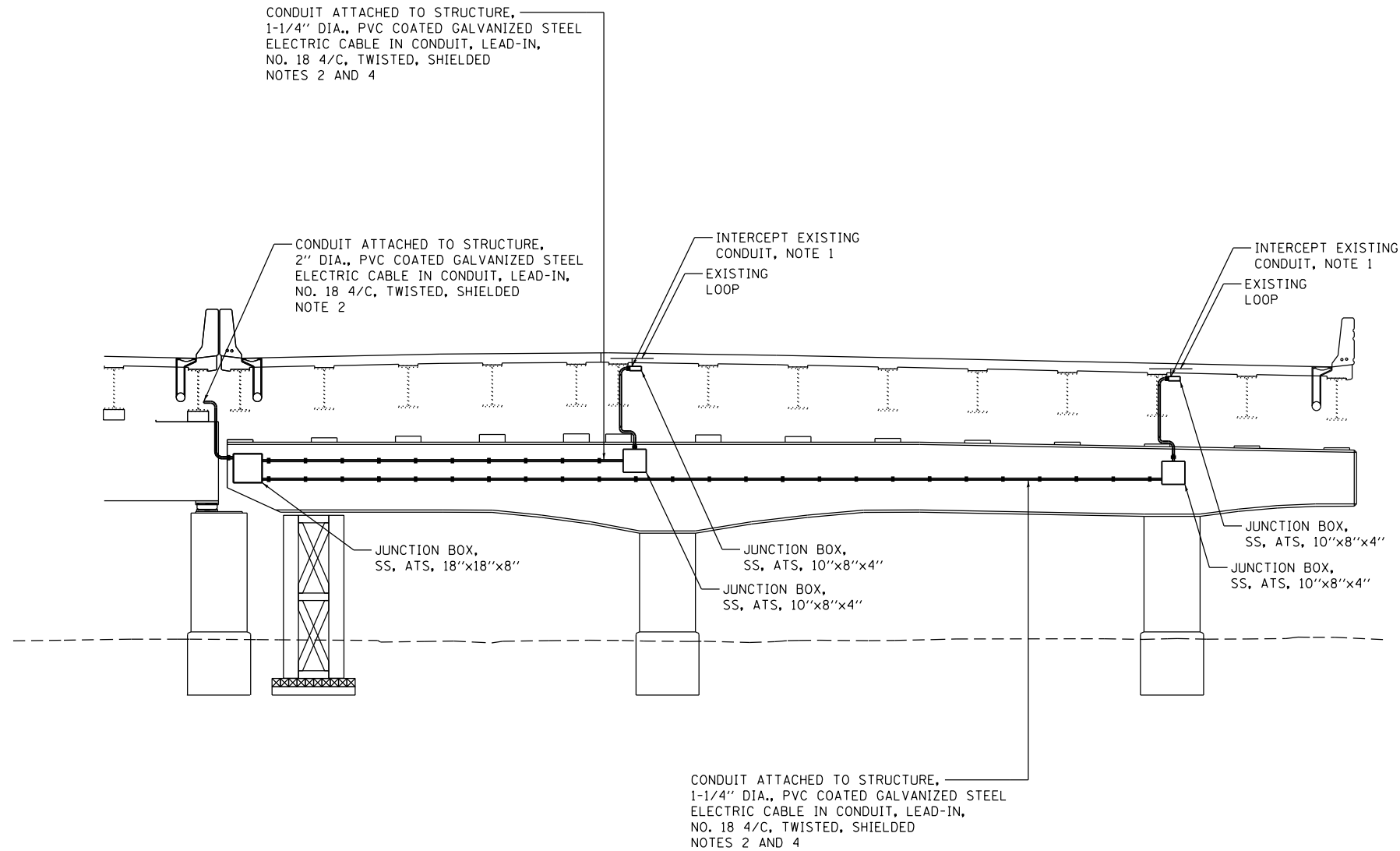

**PIER C14
(LOOKING EAST)**

NOTES:

1. INTERCEPT EXISTING LOOP WIRE/CONDUIT UNDER DECK. SPLICE EXISTING NO. 14 1 PR TO NO. 18 4/C IN 10"x8"x4" JUNCTION BOX MOUNTED UNDER DECK.
2. SEE ITS DETAILS, ITS-13, CONDUIT ATTACHED TO PIER INSTALLATION DETAIL.
3. ALL WORK SHOWN ON THIS SHEET MUST BE COORDINATED WITH THIS CONTRACT'S CONSTRUCTION WORK AND STAGING.
4. THE EXISTING LOOPS ON I-290 EB SHALL BE ROUTED AND CONNECTED TO EXISTING SURVEILLANCE CABINET Z4.
5. THE LOCATIONS OF THE ITS EQUIPMENT SHOWN ON THE PLAN ARE APPROXIMATIONS. THE FINAL INSTALLATION LOCATIONS OF THE ITS EQUIPMENT SHALL BE STAKED IN THE FIELD AND APPROVED BY THE ENGINEER PRIOR TO BEGINNING ANY WORK TO ENSURE THAT THERE ARE NO CONFLICTS WITH EXISTING/PROPOSED UTILITIES AND WORK PERFORMED BY OTHER DISCIPLINES.

ITS-10



D160X78-sht-ITS-09A	DESIGNED - GWS	REVISED -
USER NAME = myersc	DRAWN - CAM	REVISED -
PLOT SCALE = 40.0000' / in.	CHECKED - JDG	REVISED -
PLOT DATE = 3/17/2016	DATE - 3/18/2016	REVISED -

**STATE OF ILLINOIS
DEPARTMENT OF TRANSPORTATION**

**ITS DETAIL D
WB I-290 OVER I-90/94 AND WB CONGRESS PARKWAY**

SCALE: NO SCALE SHEET 10 OF 20 SHEETS STA. TO STA.

F.A.I. RTE.	SECTION	COUNTY	TOTAL SHEETS	SHEET NO.
90/94/290	2014-004R&B	COOK	706	175
CONTRACT NO. 60X78				
ILLINOIS FED. AID PROJECT				

FILE PATH = p:\61779-PMINT\pcomon\line\local\AECOM\5902_NA\Documents\01_Americas\T\engp\location\60269338_Circle\Phase_11\000_CAD\006_Roadway\Sheets\60X78_Contract\0160X78-sht-11S-10



D160X78-sht-11S-10	DESIGNED - GWS	REVISED -
USER NAME = myersc	DRAWN - CAM	REVISED -
PLOT SCALE = 2,0000' / in.	CHECKED - JDG	REVISED -
PLOT DATE = 3/17/2016	DATE - 3/18/2016	REVISED -

STATE OF ILLINOIS
DEPARTMENT OF TRANSPORTATION

ITS DETAILS
WB I-290 OVER I-90/94 AND WB CONGRESS PARKWAY

SCALE: N.T.S. SHEET 11 OF 20 SHEETS STA. TO STA.

F.A.I. R.T.E.	SECTION	COUNTY	TOTAL SHEETS	SHEET NO.
90/94/290	2014-004R&B	COOK	706	176
CONTRACT NO. 60X78				
ILLINOIS FED. AID PROJECT				

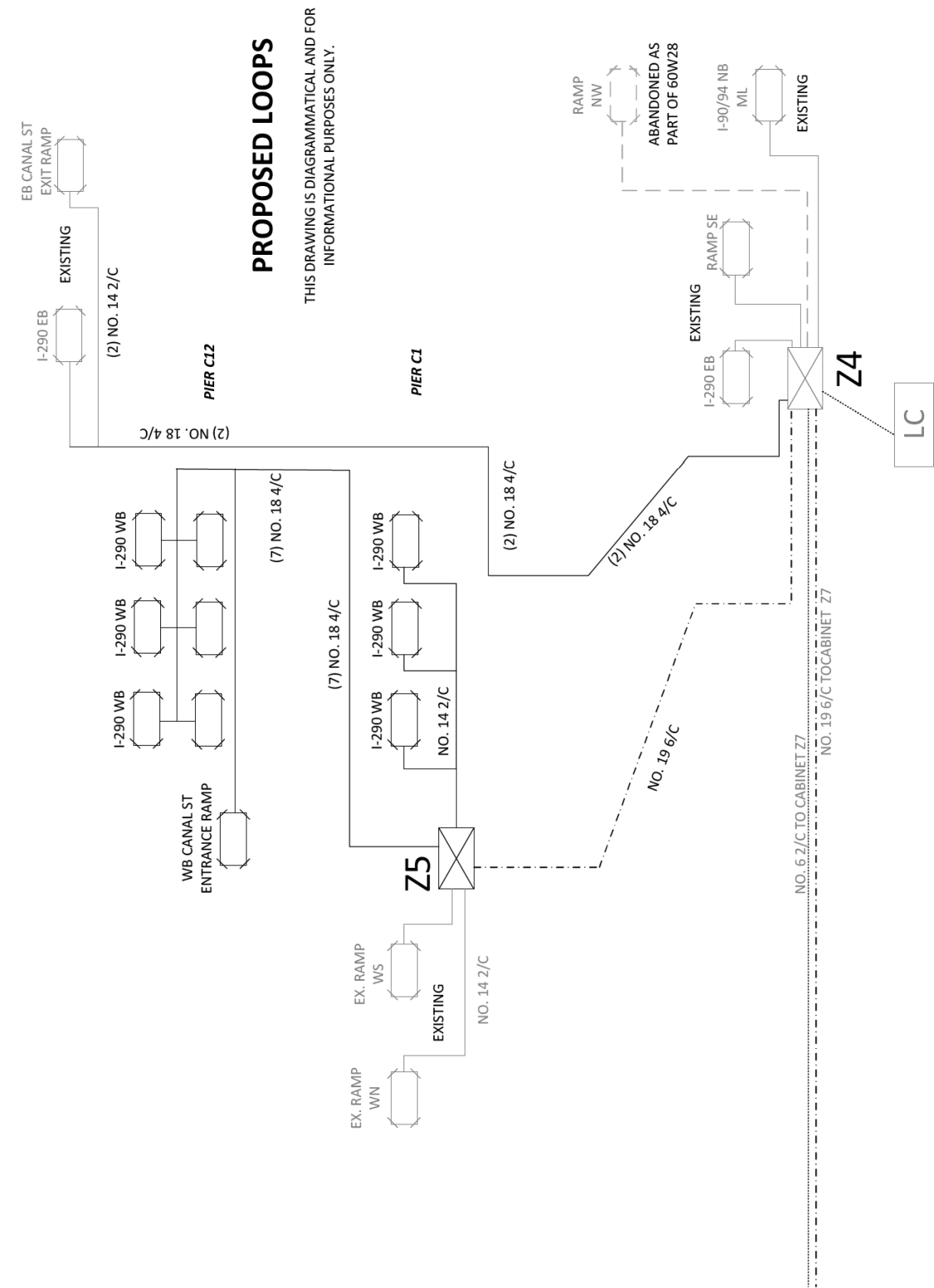
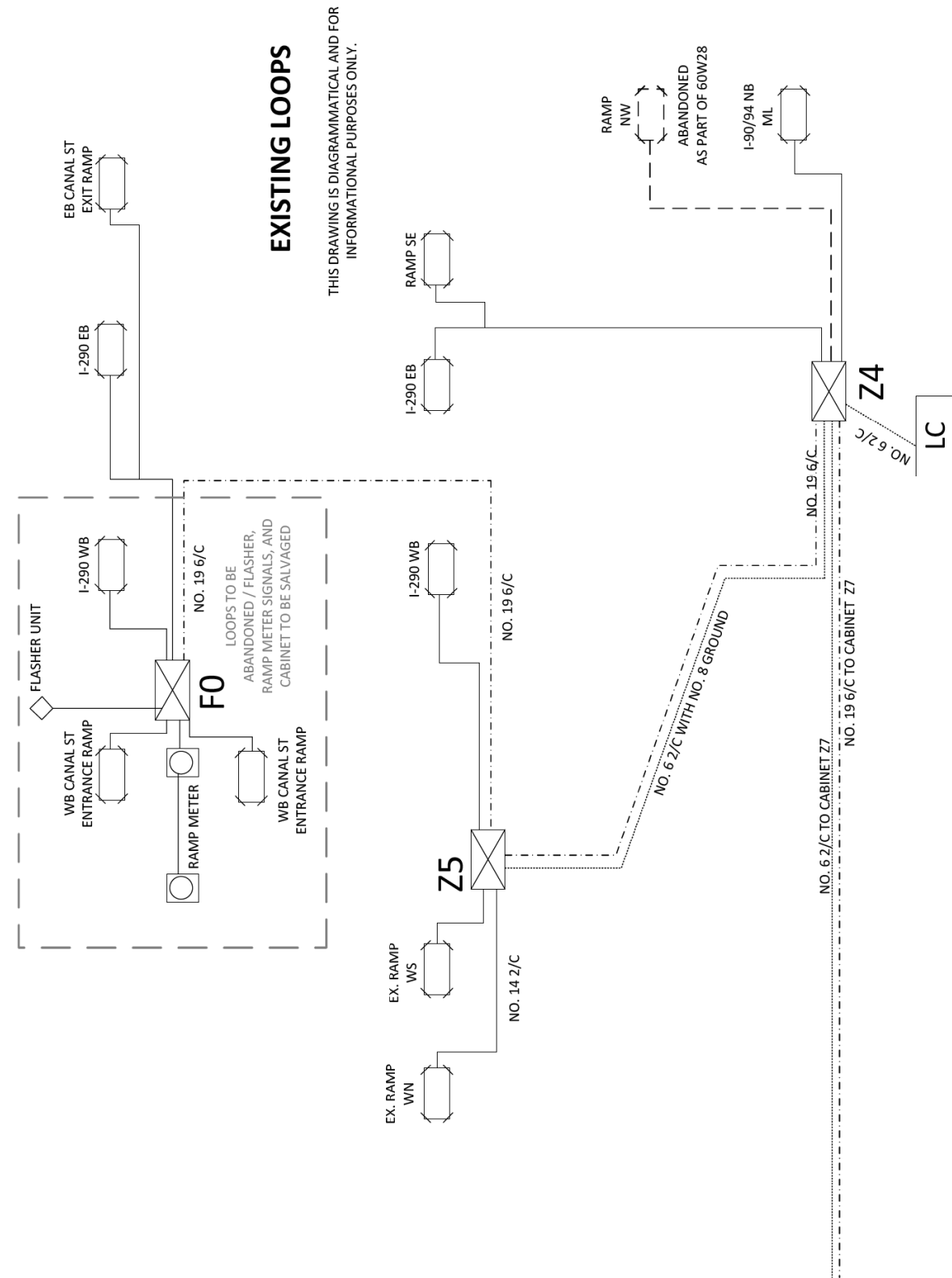

FILE PATH = p:\61779-PMINT\ecommon\line\local\AECOM_D902_NA\Documents\01_Americas\T\engp\station\60269938_Circle\Phase_11\000_CAD\006_Roadway\Sheets\60X78_Contract\0160X78-sht-ITS-11



D160X78-sht-ITS-11	DESIGNED - GWS	REVISED -
USER NAME = myersc	DRAWN - CAM	REVISED -
PLOT SCALE = 2,0000' / in.	CHECKED - JDG	REVISED -
PLOT DATE = 3/17/2016	DATE - 3/18/2016	REVISED -

STATE OF ILLINOIS
DEPARTMENT OF TRANSPORTATION

ITS DETAILS
WB I-290 OVER I-90/94 AND WB CONGRESS PARKWAY

SCALE: N.T.S. SHEET 12 OF 20 SHEETS STA. TO STA.

F.A.I. RTE.	SECTION	COUNTY	TOTAL SHEETS	SHEET NO.
90/94/290	2014-004R&B	COOK	706	177
CONTRACT NO. 60X78				
ILLINOIS FED. AID PROJECT				

EXISTING CCTV COMMUNICATIONS AND POWER

THIS DRAWING IS DIAGRAMMATICAL AND FOR INFORMATIONAL PURPOSES ONLY.

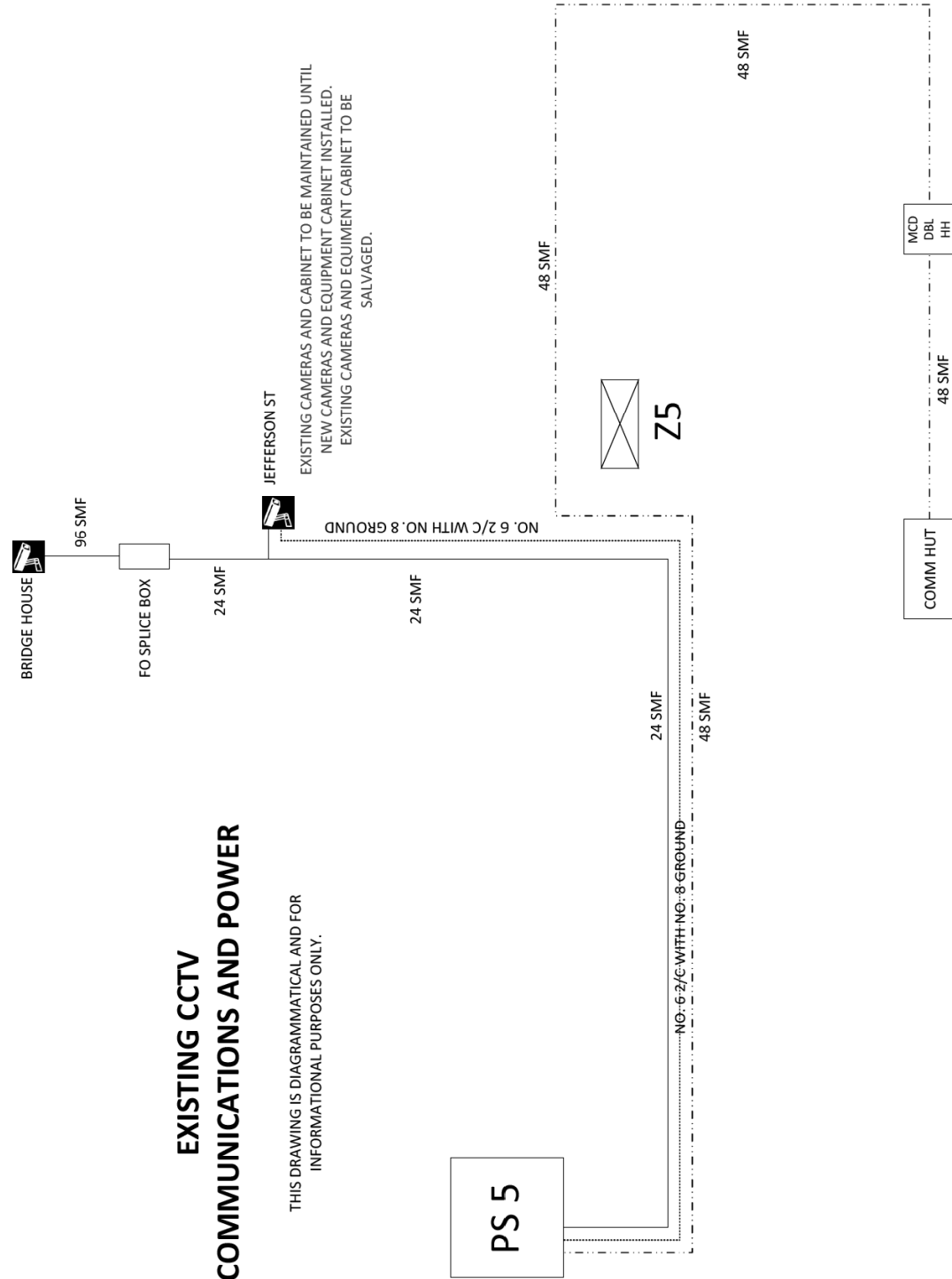

PROPOSED CCTV COMMUNICATIONS AND POWER

THIS DRAWING IS DIAGRAMMATICAL AND FOR INFORMATIONAL PURPOSES ONLY.

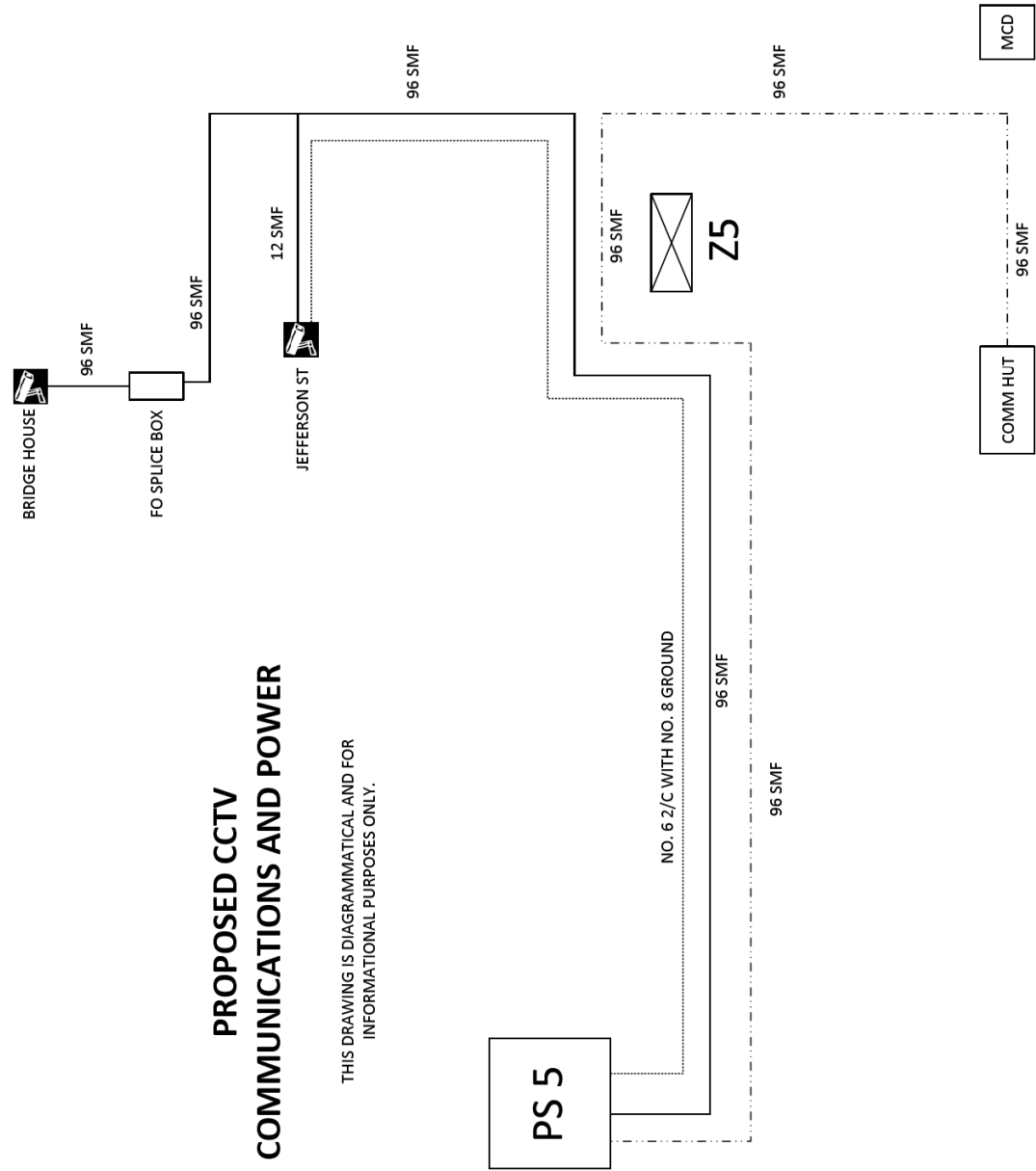

FILE PATH = p:\61779-PMINT\ecommon\line\local\AECOM_D902_NA\Documents\01_Americas\Tennessee\location\60269938_Circle\Phase_11\000_CAD\006_Roadway\Sheets\60x78_Contract\0160x78-sht-11S-12

EXISTING FIBER OPTIC CABLE ROUTING
THIS DRAWING IS DIAGRAMMATICAL AND FOR INFORMATIONAL PURPOSES ONLY.

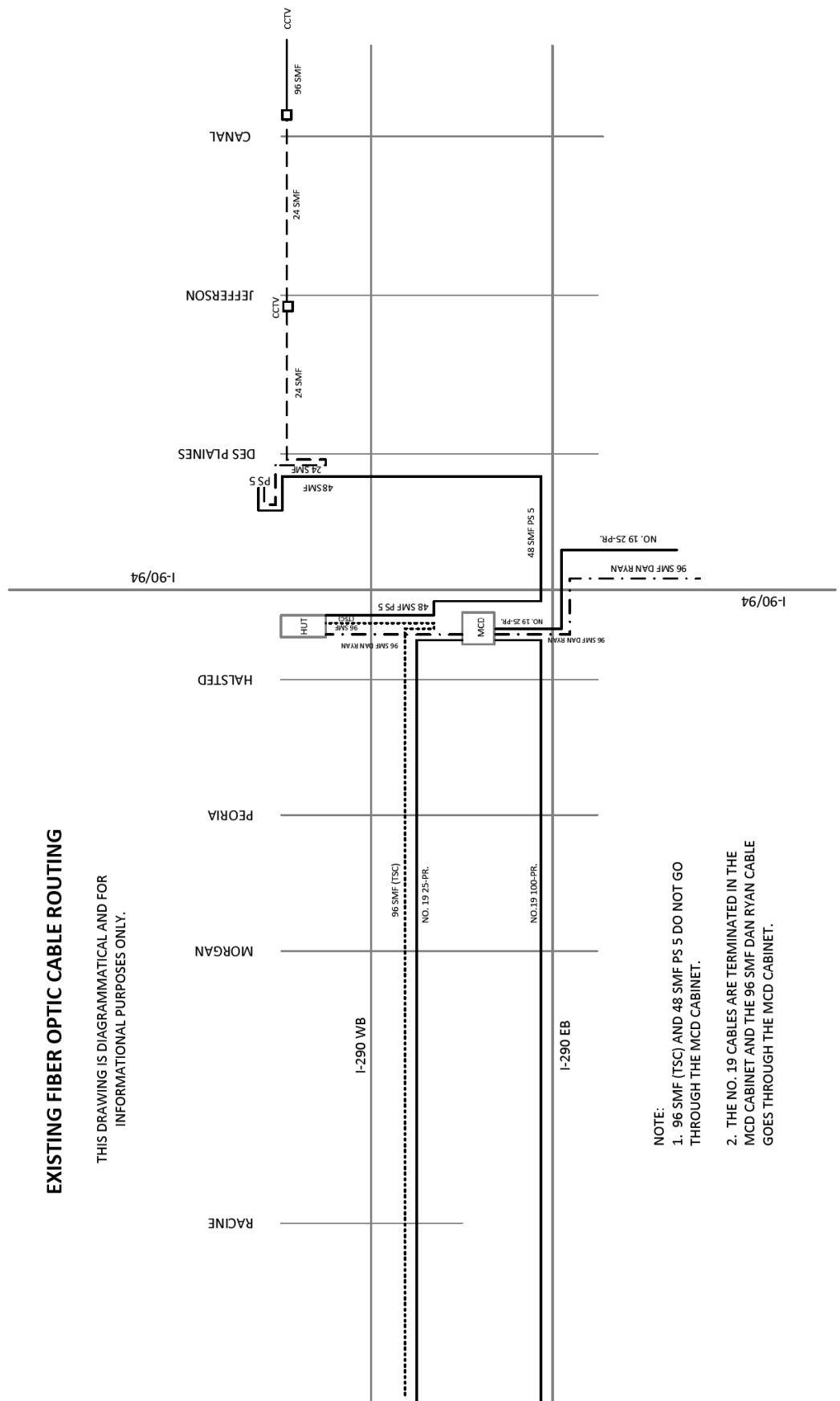

- NOTE:
 1. 96 SMF (TSC) AND 48 SMF PS 5 DO NOT GO THROUGH THE MCD CABINET.
 2. THE NO. 19 CABLES ARE TERMINATED IN THE MCD CABINET AND THE 96 SMF DAN RYAN CABLE GOES THROUGH THE MCD CABINET.

PROPOSED FIBER OPTIC CABLE ROUTING
THIS DRAWING IS DIAGRAMMATICAL AND FOR INFORMATIONAL PURPOSES ONLY.

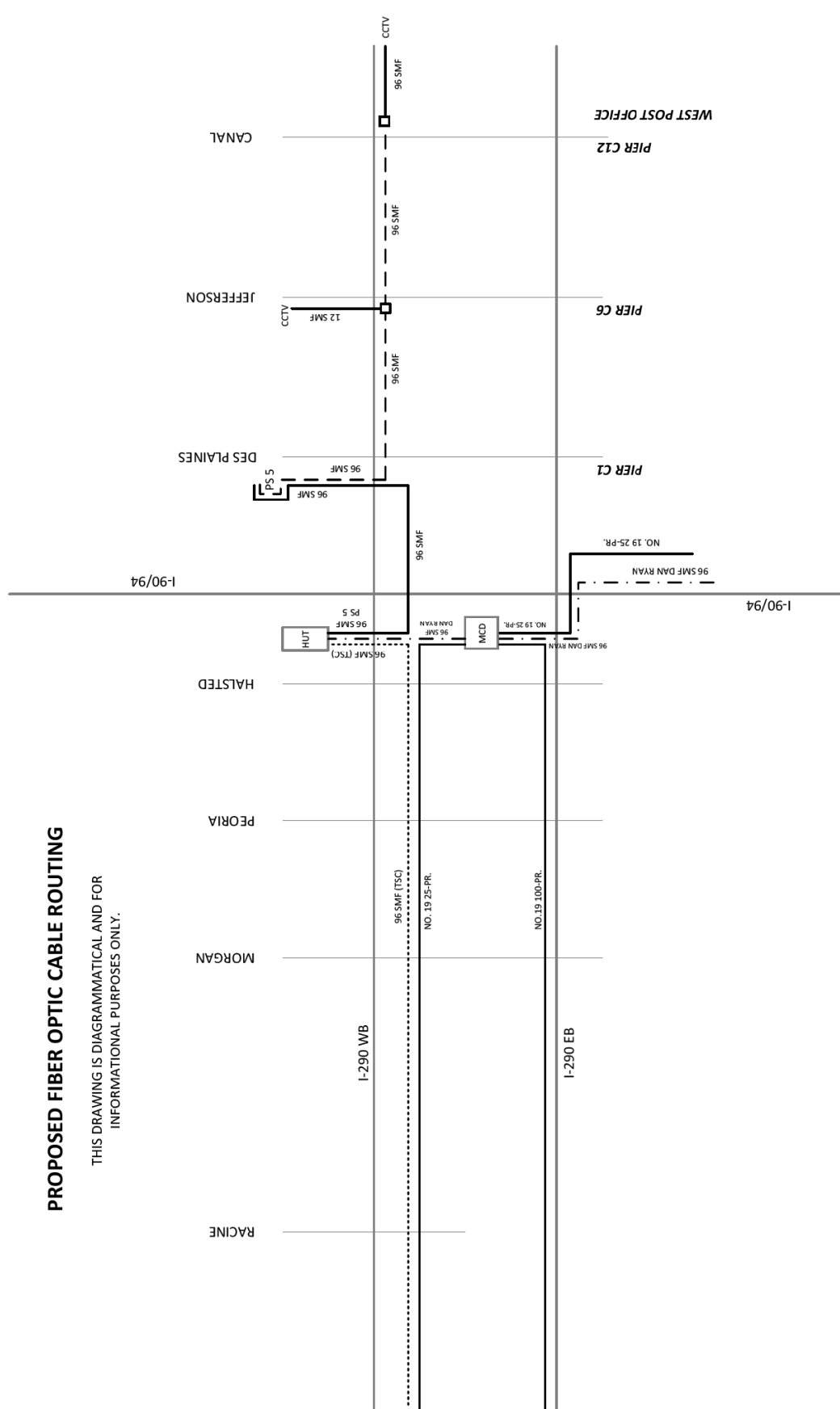

D160x78-sht-11S-12
 USER NAME = myersc
 PLOT SCALE = 2,0000' / in.
 PLOT DATE = 3/17/2016

DESIGNED - GWS	REVISED -
DRAWN - CAM	REVISED -
CHECKED - JDG	REVISED -
DATE - 3/18/2016	REVISED -

STATE OF ILLINOIS
 DEPARTMENT OF TRANSPORTATION

ITS DETAILS
 WB I-290 OVER I-90/94 AND WB CONGRESS PARKWAY

SCALE: N.T.S. SHEET 13 OF 20 SHEETS STA. TO STA.

F.A.I. RTE.	SECTION	COUNTY	TOTAL SHEETS	SHEET NO.
90/94/290	2014-004R&B	COOK	706	178
CONTRACT NO. 60X78				
ILLINOIS FED. AID PROJECT				

FILE PATH = p:\61779-PMINT.aecom\line\local\AECOM_D902_NA\Documents\01_Americas\T_engg\station\60269438_Circle\Phase_1\1000_CAD\006_Roadway\Sheets\60X78_Contract\0160X78-sht-ITS-13

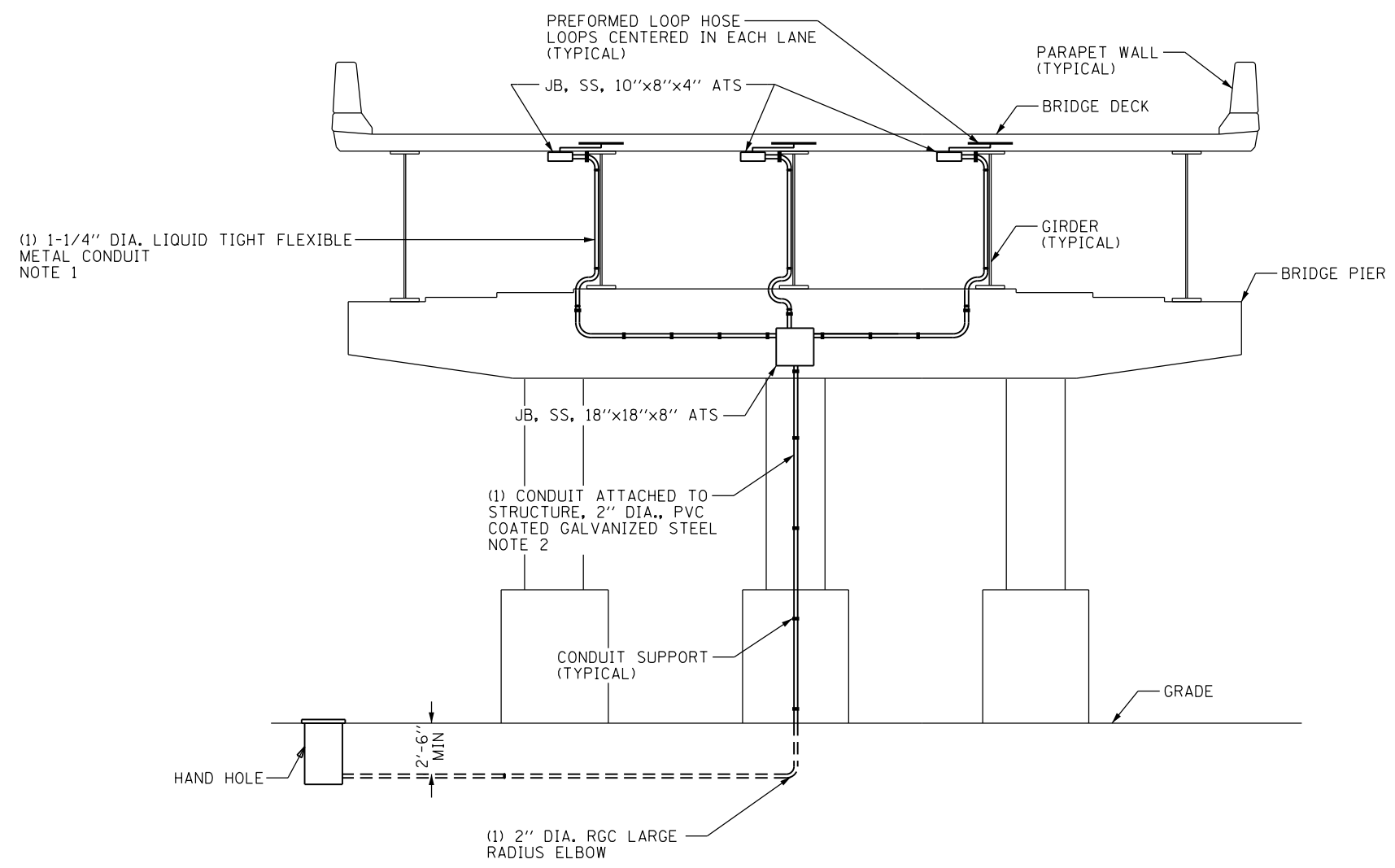

CONDUIT ATTACHED TO PIER INSTALLATION DETAIL

NOTES:

1. THE LOCATIONS OF THE ITS EQUIPMENT SHOWN ON THE PLAN ARE APPROXIMATIONS. THE FINAL INSTALLATION LOCATIONS OF THE ITS EQUIPMENT SHALL BE STAKED IN THE FIELD AND APPROVED BY THE ENGINEER PRIOR TO BEGINNING ANY WORK TO ENSURE THAT THERE ARE NO CONFLICTS WITH EXISTING/PROPOSED UTILITIES AND WORK PERFORMED BY OTHER DISCIPLINES.



D160X78-sht-ITS-13	DESIGNED - GWS	REVISED -
USER NAME = myersc	DRAWN - CAM	REVISED -
PLOT SCALE = 1.6000' / in.	CHECKED - JDG	REVISED -
PLOT DATE = 3/17/2016	DATE - 3/18/2016	REVISED -

**STATE OF ILLINOIS
DEPARTMENT OF TRANSPORTATION**

**ITS DETAILS - CONDUIT ATTACHED TO PIER STRUCTURE
WB I-290 OVER I-90/94 AND WB CONGRESS PARKWAY**

SCALE: N.T.S. SHEET 14 OF 20 SHEETS STA. TO STA.

F.A.I. RTE.	SECTION	COUNTY	TOTAL SHEETS	SHEET NO.
90/94/290	2014-004R&B	COOK	706	179
CONTRACT NO. 60X78				
ILLINOIS FED. AID PROJECT				

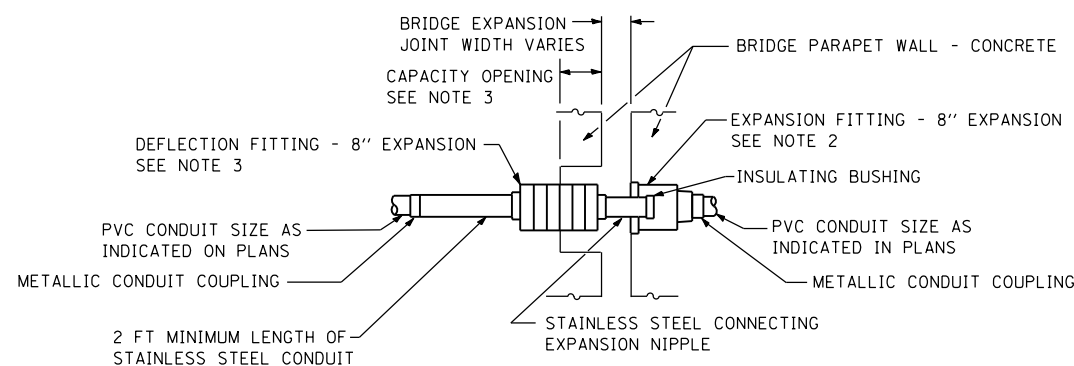

EXPANSION/DEFLECTION CONDUIT COUPLING DETAIL
NOTES 1 AND 6

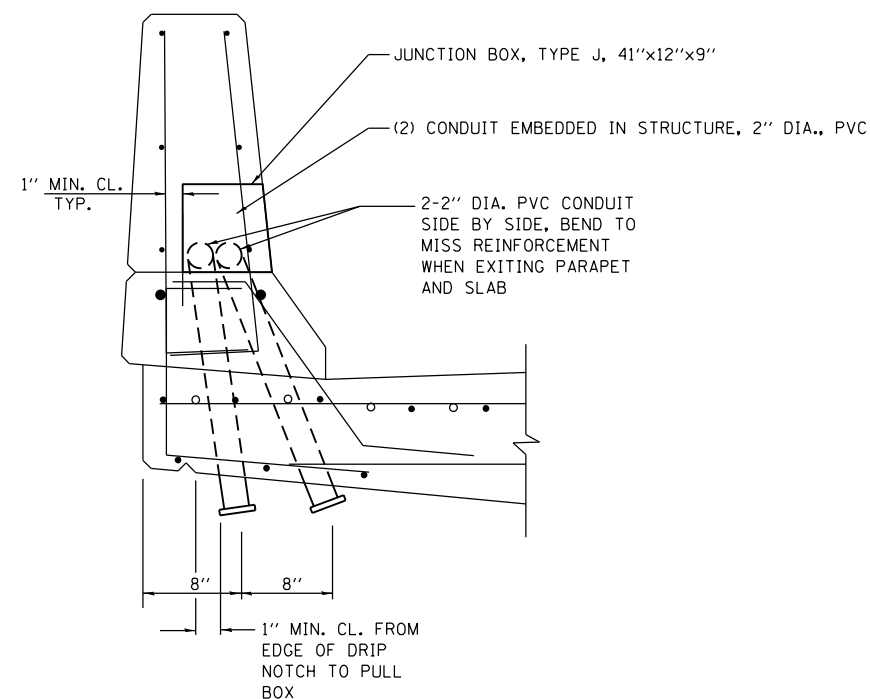

DROP-OUT AT PIER

NOTES:

1. THE CONTRACTOR SHALL INSTALL A CONDUIT EXPANSION/DEFLECTION COUPLING AT THE JOINT LOCATIONS IN THE CONCRETE PARAPET ON THE BRIDGE CAPABLE OF ACCEPTING THE LONGITUDINAL MOVEMENT. ALL METALLIC PARTS OF THE COUPLING SHALL BE MADE OF STAINLESS STEEL OR AS APPROVED BY THE ENGINEER. ANY NON-STAINLESS METAL SHALL BE HOT DIP GALVANIZED AND COATED TO PREVENT REACTION WITH THE CONCRETE. THE COST OF THE COUPLING SHALL BE PART OF AND INCIDENTAL TO THE CONDUIT SYSTEM.
2. THE BARREL IN THE EXPANSION FITTING SHALL BE IN THE CONCRETE ON ONE SIDE OF THE EXPANSION JOINT. ONE HALF THE LENGTH OF THE DEFLECTION FITTING SHALL BE EMBEDDED IN THE CONCRETE ON THE OTHER SIDE OF THE COUPLING.
3. A CAVITY OPENING 3" LARGER IN DIAMETER THAN THE DEFLECTION FITTING SHALL BE PROVIDED IN THE CONCRETE TO ENSURE PROPER PERFORMANCE OF THE COUPLING.
4. CAREFUL ATTENTION TO JOINT MOVEMENT OVER A RANGE OF TEMPERATURES SHALL BE COORDINATED WITH THE SELECTION AND INSTALLATION OF THE COUPLING TO ENSURE THE RANGE OF MOVEMENT OF THE COUPLING IS NOT EXCEEDED AT TEMPERATURE EXTREMES.
5. ALL MANUFACTURER'S INSTALLATION INSTRUCTIONS SHALL BE CAREFULLY FOLLOWED TO ENSURE OPTIMUM PERFORMANCE OF THE EXPANSION/DEFLECTION COUPLING.
6. THE CONTRACTOR SHALL INSTALL COUPLINGS AT ALL BRIDGE EXPANSION JOINTS AND SHALL BE RESPONSIBLE TO DETERMINE THE PROPER NUMBER OF COUPLINGS REQUIRED. SEE STRUCTURAL DRAWINGS FOR THE EXPANSION JOINT LOCATIONS.
7. WITH THE APPROVAL OF THE ENGINEER, THE CONTRACTOR MAY SUBSTITUTE TWO (2) STAINLESS STEEL JUNCTION BOXES ATTACHED TO THE BACK OF THE WALL AND CONNECTED BY A HIGH GRADE OF FLEXIBLE METAL CONDUIT FOR ALL EXPANSION JOINTS. THIS SUBSTITUTION SHALL BE MADE AT NO ADDITIONAL COST TO THE DEPARTMENT.
8. EXPANSION/DEFLECTION COUPLINGS ARE INCIDENTAL TO THE COST OF THE CONDUIT.
9. CONDUIT DROP-OUTS AT PIERS ARE INCIDENTAL TO THE COST OF THE TYPE J EMBEDDED JUNCTION BOX.

FILE PATH = p:\61779-PMINT\ecomon\line\loc\h\AECOM\0502_MIA\Documents\01_Americas\T\engor\station\60269438_Circle\Phase_11\000_CAD\006_Roadway\Sheets\60X78_Contract\016078-sht-ITS-14



D160X78-sht-ITS-14
USER NAME = myersc
PLOT SCALE = 2.0000' / in.
PLOT DATE = 3/17/2016

DESIGNED - WDS
DRAWN - CAM
CHECKED - WDS
DATE - 3/18/2016

REVISED -
REVISED -
REVISED -
REVISED -

**STATE OF ILLINOIS
DEPARTMENT OF TRANSPORTATION**

ITS DETAILS - ITS CONDUIT EXPANSION DETAIL
WB I-290 OVER I-90/94 AND WB CONGRESS PARKWAY
SCALE: N.T.S. SHEET 15 OF 20 SHEETS STA. TO STA.

F.A.I. RTE.	SECTION	COUNTY	TOTAL SHEETS	SHEET NO.
90/94/290	2014-004R&B	COOK	706	180
CONTRACT NO. 60X78			ILLINOIS FED. AID PROJECT	

FILE PATH = p:\6179-PMINT.aecom\line\local\AECOM_D902_NA\Documents\01_Americas\T_engsp\station\60269338_Circle\Phase_11\000_CAD\006_Roadway\Sheets\60X78_Contract\0160X78-sht-ITS-15

SHEET LEFT BLANK INTENTIONALLY

ITS-16



D160X78-sht-ITS-15	DESIGNED - GWS	REVISED -
USER NAME = dshevoz	DRAWN - CAM	REVISED -
PLOT SCALE = 2.0000' / in.	CHECKED - JDG	REVISED -
PLOT DATE = 4/27/2016	DATE - 3/18/2016	REVISED -

STATE OF ILLINOIS
DEPARTMENT OF TRANSPORTATION

ITS DETAILS
WB I-290 OVER I-90/94 AND WB CONGRESS PARKWAY

SCALE: N.T.S. SHEET 16 OF 20 SHEETS STA. TO STA.

F.A.I. RTE.	SECTION	COUNTY	TOTAL SHEETS	SHEET NO.
90/94/290	2014-004R&B	COOK	706	181
CONTRACT NO. 60X78				
ILLINOIS FED. AID PROJECT				

FILE PATH = p:\6179-PMINT\ecommon\line\local\AECOM\0902_NA\Documents\01_Americas\T\engp\station\60269438_Circle\Phase_1\000_CAD\006_Roadway\Sheets\60X78_Contract\016078-sht-17S-16

TRUNK CABLE FIBER ASSIGNMENTS			ORIGINATION: F.O. SPLICE BOX AT WEST WALL OF POST OFFICE
TRUNK CABLE DESIGNATION	TCF-96 STRAND WEST		DESTINATION: F.O. SPLICE BOX AT PS-5
BUFFER TUBE	FIBER	FIBER NO.	ASSIGNMENT
BLUE	Blue 1	1	CCTV CAMERA IKOA (at SE Br. Hse.) via Fiber #1 of 96-strand cable
	Orange 2	2	CCTV CAMERA IKOB (at SE Br. Hse.) via Fiber #1 of 96-strand cable
	Green 3	3	CCTV CAMERA IKOC (at Northwest Bridge House)
	Brown 4	4	CCTV CAMERA IKOD (at Northwest Bridge House)
	Slate 5	5	DMS Controller Ethernet Tx line
	White 6	6	DMS Controller Ethernet Rx line
	Red 7	7	CCTV CAMERA IKOE (at So. Jefferson St.) via Fiber #1 of 12-strand cable
	Black 8	8	CCTV CAMERA IKOF (at So. Jefferson St.) via Fiber #2 of 12-strand cable
	Yellow 9	9	PUMP HOUSE 7 (RESERVED)
	Violet 10	10	PUMP HOUSE 7 (RESERVED)
	Rose 11	11	PUMP HOUSE 7 (RESERVED)
	Aqua 12	12	PUMP HOUSE 7 (RESERVED)
ORANGE	Blue 1	13	DARK
	Orange 2	14	DARK
	Green 3	15	DARK
	Brown 4	16	DARK
	Slate 5	17	DARK
	White 6	18	DARK
	Red 7	19	DARK
	Black 8	20	DARK
	Yellow 9	21	DARK
	Violet 10	22	DARK
	Rose 11	23	DARK
	Aqua 12	24	DARK

NOTE: FIBERS 25 THROUGH 96 ARE DARK.

LATERAL CABLE FIBER ASSIGNMENTS			ORIGINATION: CCTV EQUIPMENT CABINET ON PIER C6	
LATERAL CABLE DESIGNATION	LCF-12 STRAND SJS		DESTINATION: F.O. SPLICE BOX ON PIER C6	
BUFFER TUBE	FIBER	FIBER NO.	ASSIGNMENT	CONNECTION
BLUE	Blue 1	1	CCTV CAMERA IKOE (at So. Jefferson St.)	Fiber #7 of 96-strand West trunk cable
	Orange 2	2	CCTV CAMERA IKOF (at So. Jefferson St.)	Fiber #8 of 96-strand West trunk cable
	Green 3	3	DARK	
	Brown 4	4	DARK	
	Slate 5	5	DARK	
	White 6	6	DARK	
	Red 7	7	DARK	
	Black 8	8	DARK	
	Yellow 9	9	DARK	
	Violet 10	10	DARK	
	Rose 11	11	DARK	
	Aqua 12	12	DARK	

ITS-17



D160X78-sht-17S-16	DESIGNED - GWS	REVISED -
USER NAME = myersc	DRAWN - CAM	REVISED -
PLOT SCALE = 2.0000' / in.	CHECKED - JDG	REVISED -
PLOT DATE = 3/17/2016	DATE - 3/18/2016	REVISED -

STATE OF ILLINOIS
DEPARTMENT OF TRANSPORTATION

CCTV SYSTEM, CONGRESS PARKWAY TO PS 5 96-STRAND TRUNK AND 12-STRAND LATERAL WB I-290 OVER I-90/94 AND WB CONGRESS PARKWAY	
SCALE: N.T.S.	SHEET 17 OF 20 SHEETS STA. TO STA.

F.A.I. RTE.	SECTION	COUNTY	TOTAL SHEETS	SHEET NO.
90/94/290	2014-004R&B	COOK	706	182
CONTRACT NO. 60X78			ILLINOIS FED. AID PROJECT	

FILE PATH = p:\61779-PMINT\ecommon\line\local\AECOM\092\092\092\092\Circle\Phase_1\1000_CAD\006_Roadway\Sheets\60X78_Contract\0160X78-sht-115-17

DISTRIBUTION CABLE FIBER ASSIGNMENTS				ORIGINATION: PUMP STATION 5				
DISTRIBUTION CABLE DESIGNATION				DESTINATION: CIRCLE INTERCHANGE COMMUNICATIONS HUT				
BUFFER TUBE	FIBER	FIBER NO.	ASSIGNMENT	BUFFER TUBE	FIBER	FIBER NO.	ASSIGNMENT	
BLUE	Blue	1	1	SLATE	Blue	1	49	DARK
	Orange	2	2		Orange	2	50	DARK
	Green	3	3		Green	3	51	DARK
	Brown	4	4		Brown	4	52	DARK
	Slate	5	5		Slate	5	53	DARK
	White	6	6		White	6	54	DARK
	Red	7	7		Red	7	55	DARK
	Black	8	8		Black	8	56	DARK
	Yellow	9	9		Yellow	9	57	DARK
	Violet	10	10		Violet	10	58	DARK
	Rose	11	11		Rose	11	59	DARK
	Aqua	12	12		Aqua	12	60	DARK
ORANGE	Blue	1	13	WHITE	Blue	1	61	DARK
	Orange	2	14		Orange	2	62	DARK
	Green	3	15		Green	3	63	DARK
	Brown	4	16		Brown	4	64	DARK
	Slate	5	17		Slate	5	65	DARK
	White	6	18		White	6	66	DARK
	Red	7	19		Red	7	67	DARK
	Black	8	20		Black	8	68	DARK
	Yellow	9	21		Yellow	9	69	DARK
	Violet	10	22		Violet	10	70	DARK
	Rose	11	23		Rose	11	71	DARK
	Aqua	12	24		Aqua	12	72	DARK
GREEN	Blue	1	25	RED	Blue	1	73	DARK
	Orange	2	26		Orange	2	74	DARK
	Green	3	27		Green	3	75	DARK
	Brown	4	28		Brown	4	76	DARK
	Slate	5	29		Slate	5	77	DARK
	White	6	30		White	6	78	DARK
	Red	7	31		Red	7	79	DARK
	Black	8	32		Black	8	80	DARK
	Yellow	9	33		Yellow	9	81	DARK
	Violet	10	34		Violet	10	82	DARK
	Rose	11	35		Rose	11	83	DARK
	Aqua	12	36		Aqua	12	84	DARK
BROWN	Blue	1	37	BLACK	Blue	1	85	DARK
	Orange	2	38		Orange	2	86	DARK
	Green	3	39		Green	3	87	DARK
	Brown	4	40		Brown	4	88	DARK
	Slate	5	41		Slate	5	89	DARK
	White	6	42		White	6	90	DARK
	Red	7	43		Red	7	91	DARK
	Black	8	44		Black	8	92	DARK
	Yellow	9	45		Yellow	9	93	DARK
	Violet	10	46		Violet	10	94	DARK
	Rose	11	47		Rose	11	95	DARK
	Aqua	12	48		Aqua	12	96	DARK

ITS-18



D160X78-sht-115-17
 USER NAME = myersc
 PLOT SCALE = 2.0000' / in.
 PLOT DATE = 3/17/2016

DESIGNED - GWS	REVISED -
DRAWN - CAM	REVISED -
CHECKED - JDC	REVISED -
DATE - 3/18/2016	REVISED -

**STATE OF ILLINOIS
DEPARTMENT OF TRANSPORTATION**

**CCTV SYSTEM, PS 5 TO COMMUNICATIONS HUT
96-STRAND TRUNK
WB I-290 OVER I-90/94 AND WB CONGRESS PARKWAY**

SCALE: N.T.S. SHEET 18 OF 20 SHEETS STA. TO STA.

F.A.I. RTE.	SECTION	COUNTY	TOTAL SHEETS	SHEET NO.
90/94/290	2014-004R&B	COOK	706	183
ILLINOIS FED. AID PROJECT			CONTRACT NO. 60X78	

(1) CAMERA STRUCTURE, 100' MOUNTING HEIGHT WITH
(2) CCTV INSTALLATIONS (IKO & IKO)

(2) 48' OF 3" PVC CONDUIT WITH
(1) 48' OF 12 SM F.O. COMM. CABLE
(1) 48' OF 2-C NO. 6 WITH NO. 8 GROUND POWER CABLE

DRILL EX. HANDHOLE

(3) 14' OF EX. CONDUIT WITH
(1) 14' OF 12 SM F.O. COMM. CABLE
(1) 14' OF 2-C NO. 6 WITH NO. 8 GROUND POWER CABLE

TERMINATE 12 SM F.O. IN COMM. HUT, CONNECT POWER CABLES TO EX. POWER PANEL IN COMM. HUT, SEE COMMUNICATION DETAILS.

APPROXIMATELY 1184' OF EX. CONDUIT WITH EX. 48 SM F.O. BETWEEN COMM. HUT AND PS-5.



EXPIRATION DATE: 11/30/2013
SHEET RANGE: 11, 24-29

NOTES

- SAW CUT AND REMOVE THE EXISTING PAVEMENT TO INSTALL THE CONDUIT. THE PAVEMENT SHALL BE RESTORED AND THE TRENCH FILLED, THE WORK TO REMOVE AND RESTORED THE EXISTING PAVEMENT INCLUDING ALL MATERIALS, DISPOSAL AND BACKFILLING WILL NOT BE PAID FOR SEPARATELY AND SHALL BE INCLUDED IN THE COST OF THE "UNDERGROUND CONDUIT, GALVANIZED STEEL, 3" DIA." PAY ITEM.

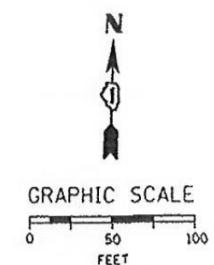
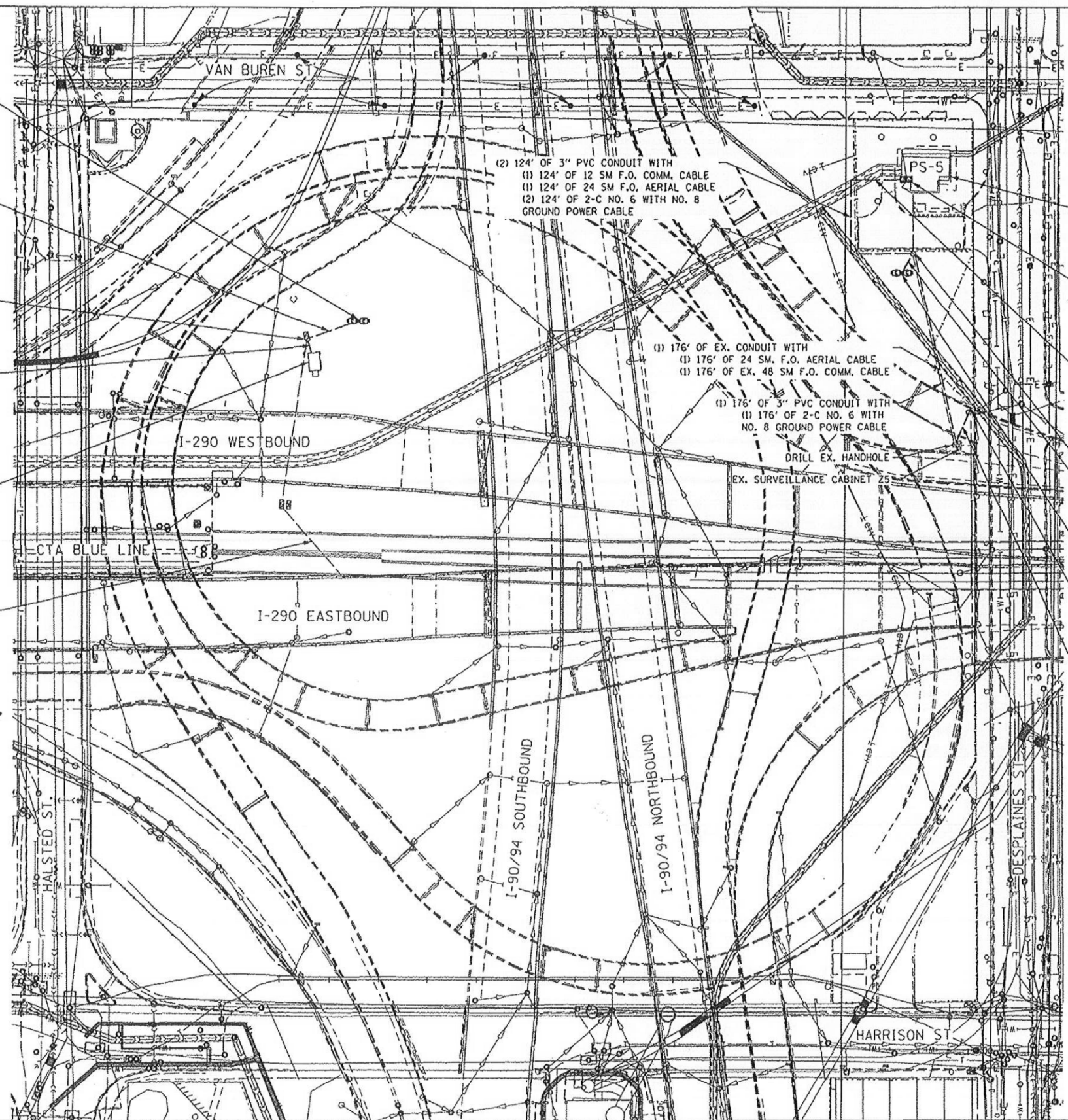

TERMINATE 12 SM F.O. AND 24 SM F.O. IN PS-5. CONNECT POWER CABLES TO EXISTING LIGHTING PANEL IN PS-5. SEE COMMUNICATION DETAILS AND PUMP STATION DETAILS.

(2) JB, SS, 12"x12"x6" ATS
(2) 20' OF 3" PVC G.S. CONDUIT ATS WITH
(1) 20' OF 12 SM F.O. COMM. CABLE
(1) 20' OF 24 SM F.O. AERIAL CABLE
(2) 20' OF 2-C NO. 6 WITH NO. 8 GROUND POWER CABLE

SEE NOTE 1.
(2) 51' OF 3" PVC CONDUIT WITH
(1) 51' OF 12 SM F.O. COMM. CABLE
(1) 51' OF 24 SM F.O. COMM. CABLE
(2) 51' OF 2-C NO. 6 WITH NO. 8 GROUND POWER CABLE

DRILL EX. HANDHOLE

(2) 20' OF 3" PVC CONDUIT WITH
(1) 20' OF 12 SM F.O. COMM. CABLE
(1) 20' OF 2-C NO. 6 WITH NO. 8 GROUND POWER CABLE

(1) CAMERA STRUCTURE, 100' MOUNTING HEIGHT WITH
(2) CCTV INSTALLATIONS (IKO & IKO)

(1) 14' OF 2" PVC COATED G.S. CONDUIT ATS WITH
(1) 14' OF 24 SM F.O. AERIAL CABLE
(1) 14' OF 2-C NO. 6 WITH NO. 8 GROUND POWER CABLE

(1) 38' OF 2" PVC CONDUIT UNDERGROUND WITH
(1) 38' OF 24 SM F.O. AERIAL CABLE
(1) 38' OF 2-C NO. 6 WITH NO. 8 GROUND POWER CABLE

RECORD DRAWING
Meade, Inc.

By *[Signature]* Date *2/2/15*

LEGEND

- ⊙ EXISTING HANDHOLE
- ⊞ EXISTING CABINET
- PROPOSED CCTV POLE
- ⊕ PROPOSED CCTV ASSEMBLY
- - - EXISTING UNDERGROUND CABLE
- - - PROPOSED UNDERGROUND CABLE



DIG049-sht-ITS-01
USER NAME = lachery
PLOT SCALE = 100.0000' / in.
PLOT DATE = 10/24/2013

DESIGNED - JML	REVISED -
DRAWN - JML	REVISED -
CHECKED - WDS	REVISED -
DATE - 10/18/2013	REVISED -

STATE OF ILLINOIS
DEPARTMENT OF TRANSPORTATION

HALSTED STREET AND HARRISON STREET - ITS PLANS
PROPOSED ITS

SCALE: 1" = 50' SHEET 1 OF 5 SHEETS STA. TO STA.

F.A.I. RTE.	SECTION	COUNTY	TOTAL SHEETS	SHEET NO.
389	2013-26-1	COOK	37	11
FED. ROAD DIST. NO. 1			ILLINOIS FED. AID PROJECT	

ITS-19



D16078-sht-ITS-18
USER NAME = myersc
PLOT SCALE = 2.0000' / in.
PLOT DATE = 3/17/2016

DESIGNED - GWS	REVISED -
DRAWN - CAM	REVISED -
CHECKED - JDC	REVISED -
DATE - 3/18/2016	REVISED -

STATE OF ILLINOIS
DEPARTMENT OF TRANSPORTATION

ITS DETAILS - RECORD DRAWING
WB I-290 OVER I-90/94 AND WB CONGRESS PARKWAY

SCALE: N.T.S. SHEET 19 OF 20 SHEETS STA. TO STA.

F.A.I. RTE.	SECTION	COUNTY	TOTAL SHEETS	SHEET NO.
90/94/290	2014-004R&B	COOK	706	184
ILLINOIS FED. AID PROJECT			CONTRACT NO. 60X78	

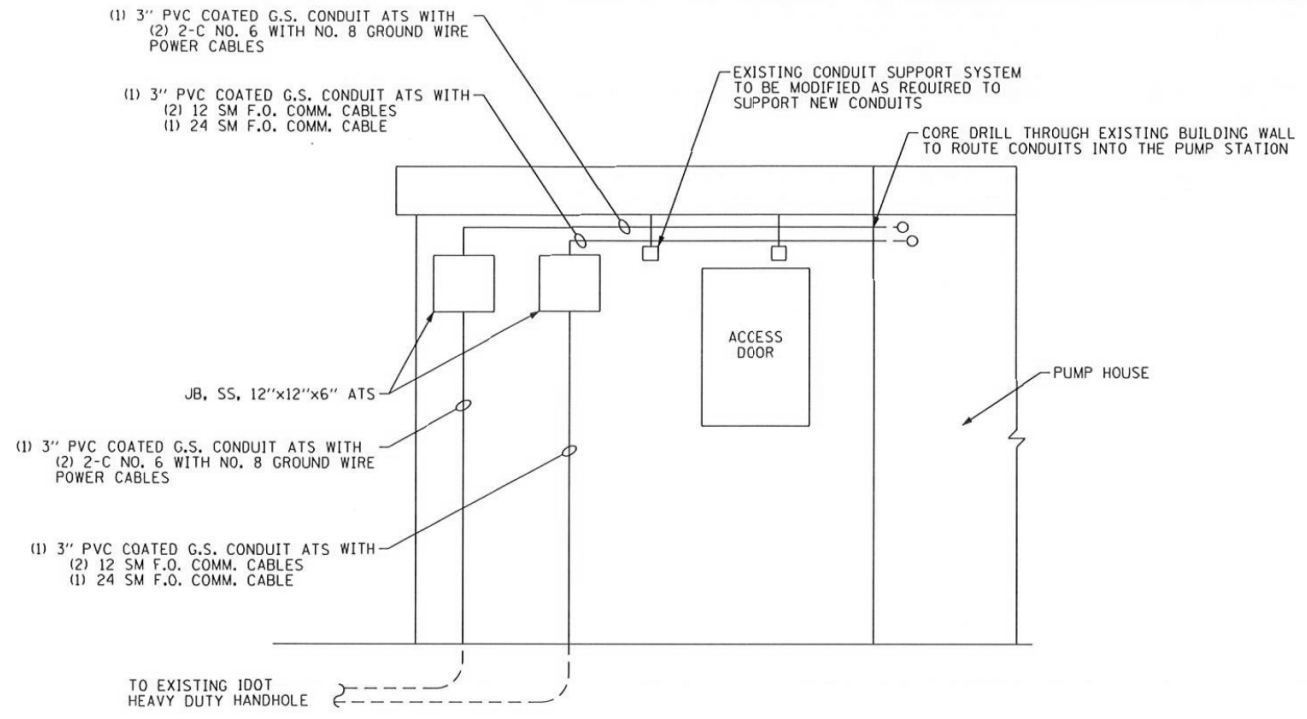

IDOT PUMP STATION NO. 5 - PARTIAL ELEVATION VIEW (LOOKING NORTH)
NOT TO SCALE

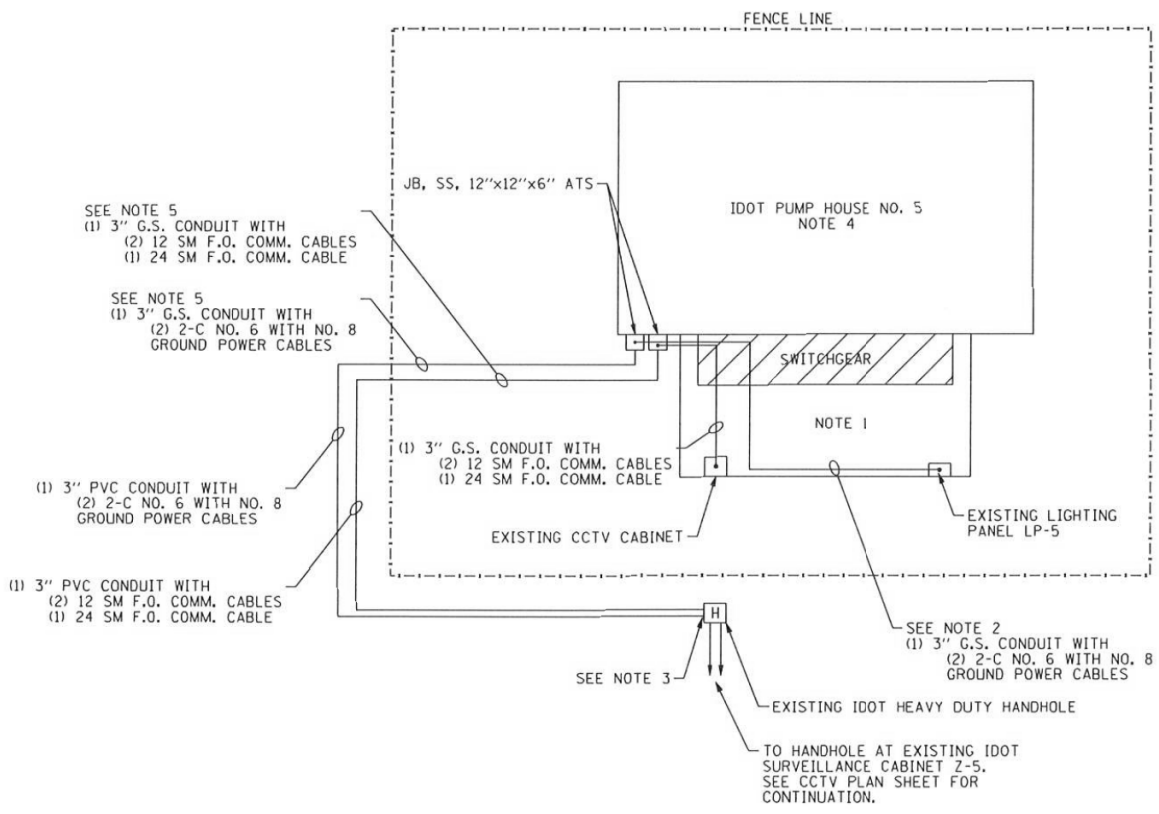

IDOT PUMP STATION NO. 5 - PLAN VIEW
NOT TO SCALE

RECORD DRAWING
Meade, Inc.

By *[Signature]* Date *2/2/15*

- NOTES:**
1. ALL WORK TO INSTALL THE POWER AND FIBER OPTIC CABLES IN CONDUIT FROM THE NEW JUNCTION BOXES TO THE CCTV CABINET AND LIGHTING PANEL SHALL BE INCLUDED IN THE LUMP SUM "PUMP STATION ELECTRICAL WORK" PAY ITEM.
 2. CONNECT THE CCTV CAMERA POWER CABLES TO TWO EXISTING SPARE 1-POLE, 20 AMP CIRCUIT BREAKERS LOCATED IN THE EXISTING LIGHTING PANEL.
 3. THE CONTRACTOR SHALL DRILL THROUGH THE EXISTING HEAVY DUTY HANDHOLE WALL TO CONNECT THE NEW 3" CONDUITS AS SHOWN.
 4. ALL WORK SHALL BE COORDINATED WITH IDOT PUMP STATION MAINTENANCE PERSONNEL.
 5. SAW CUT AND REMOVE THE EXISTING PAVEMENT TO INSTALL THE CONDUIT. THE PAVEMENT SHALL BE RESTORED AND THE TRENCH FILLED. THE WORK TO REMOVE AND RESTORED THE EXISTING PAVEMENT INCLUDING ALL MATERIALS, DISPOSAL AND BACKFILLING WILL NOT BE PAID FOR SEPARATELY AND SHALL BE INCLUDED IN THE COST OF THE "UNDERGROUND CONDUIT, GALVANIZED STEEL, 3" DIA." PAY ITEM.

AECOM 303 EAST WACKER DRIVE, SUITE 1400 CHICAGO, IL 60601-5274 PHONE: (312) 373-7700 FAX: (312) 373-6800	D160V49-sht-ITS-02	DESIGNED - WDS	REVISED -	STATE OF ILLINOIS DEPARTMENT OF TRANSPORTATION	CCTV SYSTEM, I-90/4 CONGRESS PARKWAY PUMP STATION DETAILS		F.A.I. RTE. 389	SECTION 2013-26-1	COUNTY COOK	TOTAL SHEETS 37	SHEET NO. 26
	USER NAME = lacherj PLOT SCALE = 2.0000' / in. PLOT DATE = 10/21/2013	DRAWN - CAM CHECKED - WDS DATE - 10/18/2013	REVISED - REVISED - REVISED -		SCALE: NONE SHEET 2 OF 5 SHEETS STA. TO STA.	CONTRACT NO. 60W49 FED. ROAD DIST. NO. 1 ILLINOIS FED. AID PROJECT					

AECOM 303 EAST WACKER DRIVE, SUITE 1400 CHICAGO, IL 60601-5274 PHONE: (312) 373-7700 FAX: (312) 373-6800	D160X78-sht-ITS-19	DESIGNED - GWS	REVISED -	STATE OF ILLINOIS DEPARTMENT OF TRANSPORTATION	ITS DETAILS - RECORD DRAWING WB I-290 OVER I-90/4 AND WB CONGRESS PARKWAY		F.A.I. RTE. 90/94/290	SECTION 2014-004R&B	COUNTY COOK	TOTAL SHEETS 706	SHEET NO. 185
	USER NAME = myersc PLOT SCALE = 2.0000' / in. PLOT DATE = 3/17/2016	DRAWN - CAM CHECKED - JDG DATE - 3/18/2016	REVISED - REVISED - REVISED -		SCALE: N.T.S. SHEET 20 OF 20 SHEETS STA. TO STA.	CONTRACT NO. 60X78 ILLINOIS FED. AID PROJECT					

Bench Mark: Square cut at center of door entrance to 707 W. Harrison St. South side of Harrison St. ±90' west of west line of Des Plaines. Elevation 597.47 BM 1366.
 A * cut in the SE anchor bolt at the 11th street light N. of Roosevelt on the W. side of Halsted. Elev. 594.06 BM 1347.
 Existing Structure: S.N. 016-1703 was originally built in 1953 as F.A. Route Number 131. The existing structure consists of 7 spans; 1 approach span of reinforced concrete superstructure and 6 main spans of multi-unit steel continuous multi-beam superstructures. The existing structure has an overall length of 502'-0" and an out-to-out width of 57'-6". The substructure units are founded on sub-piers and consist of 8 multi column piers. The existing bridge is to be removed and replaced.

Traffic Control: Two lanes of traffic will be maintained on existing S.N. 016-1030 (WB I-290) utilizing stage construction.

No Salvage.

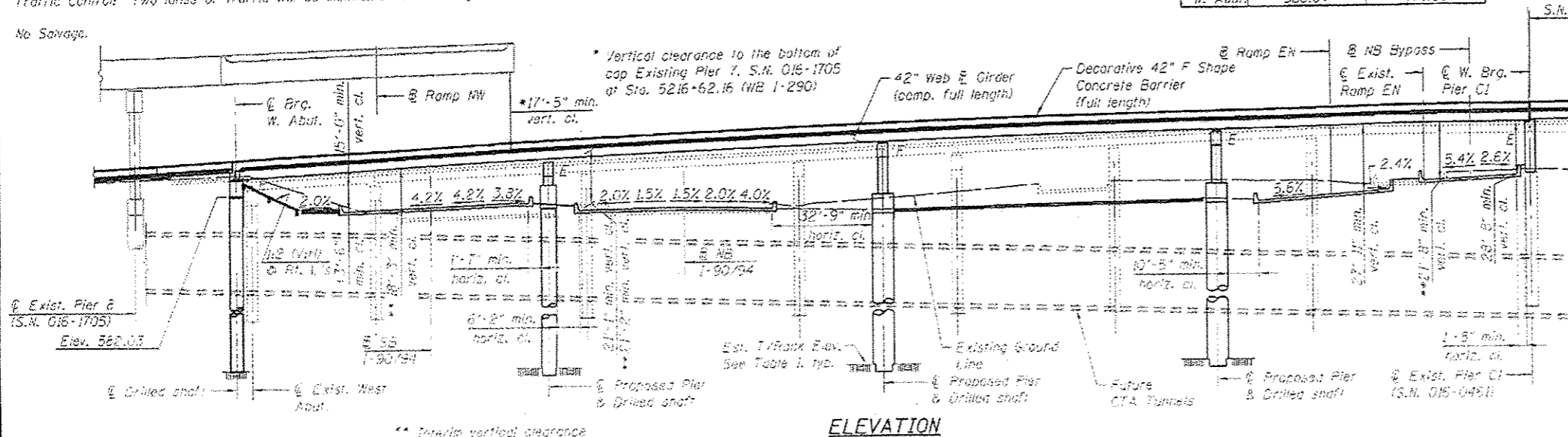

ELEVATION

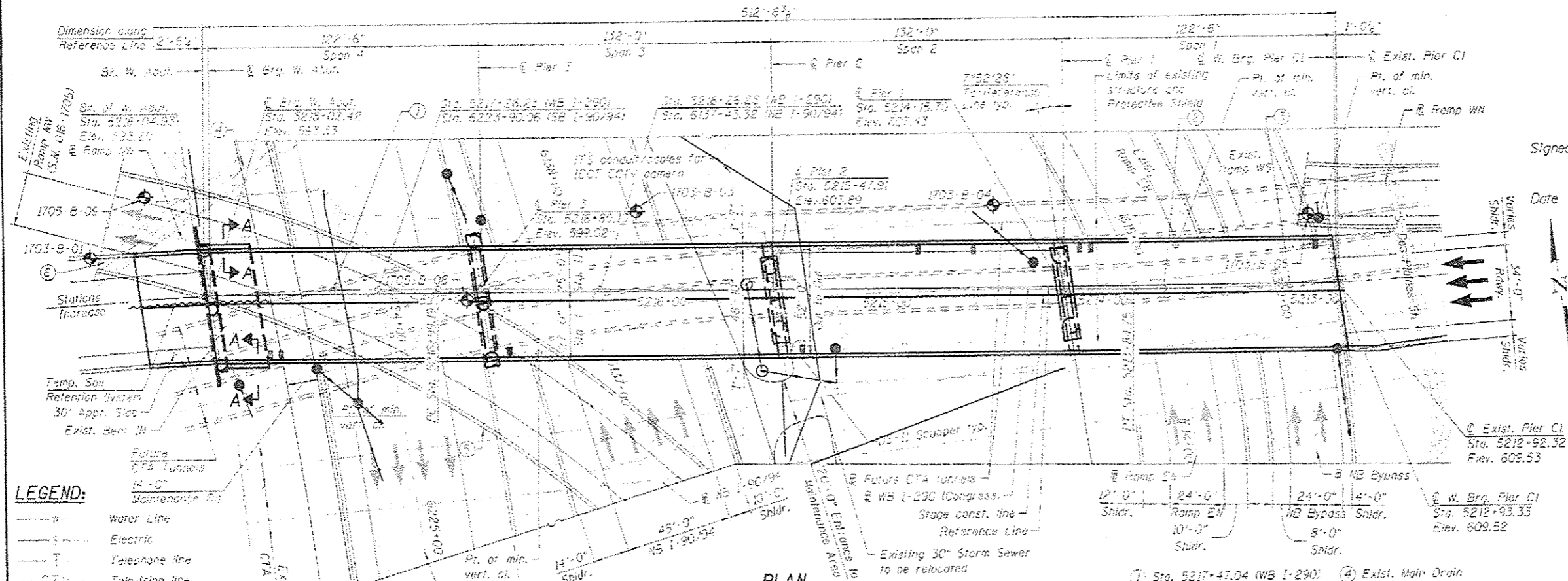

PLAN

LEGEND:

- Water Line
- Electric
- Telephone line
- Television line
- Combined Sewer
- Storm Sewer
- ⊙ Point of min. vert. cl.
- ⊙ Soil Boring Location

Notes:

1. Span lengths are measured along Reference Line. Plan view is oriented with spans and stations increasing to the left so that plan view is oriented with that of existing structure (S.N. 016-1030) and I-290 viaduct (S.N. 016-0461).
2. For Section A-A, See sheet S1-3.

TABLE 1

	Estimated T/Ground Elev.	Estimated T/Rock Elev.
Pier 1	576.4±	478.70
Pier 2	575.4±	475.50
Pier 3	578.0±	479.10
W. Abut.	586.0±	479.60

DESIGN SPECIFICATIONS

2014 AASHTO LRFD Bridge Design Specifications 7th Edition
LOADING HL-93
 Allow 50#/sq. ft. for future wearing surface.

DESIGN STRESSES

FIELD UNITS
 f'_c = 3,500 psi
 f_y = 60,000 psi (Reinforcement)
 f_y = 50,000 psi (M270 Grade 50)

SEISMIC DATA

Seismic Performance Zone (SPZ) = 1
 Design Spectral Acceleration at 1.0 sec. (S₁₀) = 0.085g
 Design Spectral Acceleration at 0.2 sec. (S_{0.2}) = 0.144g
 Soil Site Class = 0

SCUPPER LOCATION

Station	Offset
5213+02.00	20.01' Rt.
5214+04.20	20.91' Rt.
5214+09.20	23.86' Rt.
5214+57.29	20.31' Rt.
5214+82.30	20.02' Rt.
5215+34.72	29.42' Lt.
5216+67.46	30.94' Lt.
5217+71.72	30.55' Lt.
5217+76.72	30.39' Lt.

APPROVED
 For Structural Adequacy Only

Jamal Grainawi
 Engineer of Bridges & Structures



Signed *Jamal Grainawi*
 JAMAL I. GRAINAWI, S.E. II, Lic. No. 081-005161
 Expires 11-30-2016.

Date **3/18/2016**

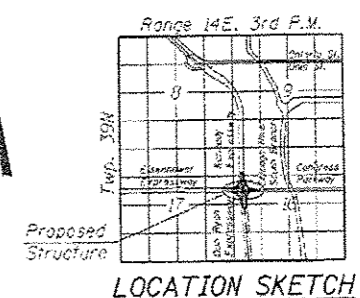

GENERAL PLAN & ELEVATION

WB I-290 (CONGRESS) OVER I-90/94
F.A.I. ROUTE 90/94/290
SECTION 2014-004R&B
COOK COUNTY
STATION 5216+26.28
STRUCTURE NO. 016-1703



USER NAME	DATE	DESIGNED	BY	REVISIONS
P.J.L.				
J.Z.				
D.C.P.				
J.C.				

STATE OF ILLINOIS
 DEPARTMENT OF TRANSPORTATION

F.A.I. R.T.E.	SECTION	COUNTY	TOTAL SHEETS	SHEET NO.
90/94/290	2014-004 R&B	COOK	706	186

SHEET NO. S1-01 OF S1-53 SHEETS
 ILLINOIS FED. AID PROJECT
 CONTRACT NO. 60X78

GENERAL NOTES:

- Fasteners shall be ASTM A325 Type 1, hot dipped galvanized bolts. Bolts 7/8" φ, holes 15/16" φ, unless otherwise noted.
- Calculated weight of Structural Steel = 1,066,960 lbs.
- All structural steel shall be AASHTO M270 Grade 50.
- All structural steel shall be hot-dip galvanized (see special provisions).
- No field welding is permitted except as specified in the contract documents.
- Reinforcement bars designated (E) shall be epoxy coated.
- Plan dimensions and details relative to existing plans are subject to nominal construction variations. The Contractor shall field verify existing dimensions and details affecting new construction and make necessary approved adjustments prior to construction or ordering of materials. Such variations shall not be cause for additional compensation for a change in scope of the work, however, the Contractor will be paid for the quantity actually furnished at the unit price bid for the work.
- Bearing seat surfaces shall be constructed or adjusted to the designated elevations within a tolerance of 1/8" (0.01 ft.). Adjustment shall be made either by grinding the surface or by shimming the bearings.
- Concrete Sealer shall be applied to the designated areas of the Piers, West Abutment and Wingwalls.
- The existing structural steel coating contains lead. The Contractor shall take appropriate precautions to deal with the presence of lead on this project.
- Slipforming of the parapet is not allowed.
- Limited groundwater elevation data is available in the boring logs. In addition, groundwater may also be present in deeper granular layers. The groundwater may rise in the shafts to an elevation above the top of granular layers. The Contractor shall consider this information when choosing construction methods. The Contractor will not be compensated for issues related to the groundwater elevation.
- Temporary Soil Retention System shall be as per Std. Spec. Section 522.07 and as modified herein. Temporary Soil Retention System shall be installed without the use of impact-type pile drivers. The proposed equipment and procedures used for the installation of Temporary Soil Retention System shall be submitted to the Engineer for approval prior to their use. If vibratory equipment utilized, the Contractor shall also submit documentation regarding the operating noise levels and operating vibration characteristics of the equipment proposed. The approval of the equipment and procedure by the Engineer does not guarantee the performance in the field of the equipment will be acceptable. If in the judgment of the Engineer, the noise and/or vibration effects exceed those required by the local residents, then the Contractor must halt production and find a remedy suitable to the Engineer. Threshold values for vibration monitoring are included in the special provision "CONSTRUCTION VIBRATION MONITORING". The costs incurred finding suitable equipment and procedures shall be included in the cost of Temporary Soil Retention System. No additional costs shall be paid for this effort.

STRUCTURAL ASSESSMENT OF EXISTING STRUCTURE NOTES:

- In order to construct proposed superstructure & substructure elements, Contractor may elect to support temporary construction material and/or equipment, on the existing structures in the vicinity of the proposed structure. The Contractor shall submit Structural Assessment Report(s) for approval prior to beginning the work. See Special Provision.
- An Existing Structure Information Package (ESIP) will be provided by the Department to the Contractor upon request.
- The Contractor shall retain the services of an engineering firm, prequalified in the IDOT consultant selection category of Highway Bridge (Adv. Typical), for preparation of the Structural Assessment Report(s). Contractor's pre-approval shall not be applicable for this project. See Special Provision.

Current Ratings on File for Existing Structures are as follows:

S.N. 016-1029 (EB I-290 over I-90/94)
Inventory: HS 17.2
Operating: HS 28.7
Live Load Restrictions: None

S.N. 016-1030 (WB I-290 over I-90/94)
Inventory: HS 14.7
Operating: HS 24.5
Live Load Restrictions: None

S.N. 016-2450 (Ramp WB I-290 to SB I-90/94 over I-90/94)
Inventory: HS 14.2
Operating: HS 23.6
Live Load Restrictions: None

INDEX OF SHEETS

- SI-1 General Plan and Elevation
- SI-2 General Data I
- SI-3 General Data II
- SI-4 Curve Data & Geometric Layout
- SI-5 Substructure Layout
- SI-6 Temporary Soil Retention System
- SI-7 Stage Construction Details
- SI-8 Existing Structure Removal Details I
- SI-9 Existing Structure Removal Details II
- SI-10 Existing Structure Removal Details III
- SI-11 Temporary Concrete Barrier for Stage Construction
- SI-12 Top of Slab Elevation Plan
- SI-13 Top of Slab Elevations I
- SI-14 Top of Slab Elevations II
- SI-15 Top of Slab Elevations III
- SI-16 Top of Slab Elevations IV
- SI-17 Top of West Approach Slab Elevations
- SI-18 Deck Plan I
- SI-19 Deck Plan II
- SI-20 Deck Details I
- SI-21 Deck Details II
- SI-22 Concrete Diaphragm Details
- SI-23 Precast Bridge Approach Details I
- SI-24 Precast Bridge Approach Details II
- SI-25 Precast Bridge Approach Details III
- SI-26 Precast Bridge Approach Details IV
- SI-27 Drainage System
- SI-28 Drainage Scupper, DS-II
- SI-29 Framing Plan
- SI-30 Superstructure Steel Details I
- SI-31 Superstructure Steel Details II
- SI-32 Superstructure Steel Details III
- SI-33 Bearing Details I
- SI-34 Bearing Details II
- SI-35 Bearing Details III
- SI-36 Pier 1
- SI-37 Pier 1 Details
- SI-38 Pier 1 Architectural Details
- SI-39 Pier 2
- SI-40 Pier 2 Details
- SI-41 Pier 2 Architectural Details
- SI-42 Pier 3
- SI-43 Pier 3 Details
- SI-44 Pier 3 Architectural Details
- SI-45 West Abutment
- SI-46 West Abutment Details
- SI-47 Bar Splicer Assembly and Mechanical Splicer Details
- SI-48 Boring Logs I
- SI-49 Boring Logs II
- SI-50 Boring Logs III
- SI-51 Boring Logs IV
- SI-52 Boring Logs V
- SI-53 Boring Logs VI

TOTAL BILL OF MATERIAL

ITEM	UNIT	SUPER	SUB	TOTAL
Removal of Existing Structures No. 1	Each	1		1
Protective Shield	Sq. Yd.	3,222		3,222
Structure Excavation	Cu. Yd.	-	994	994
Concrete Structures	Cu. Yd.	-	622	622
Concrete Superstructure	Cu. Yd.	877	-	877
Bridge Deck Grooving	Sq. Ft.	2,818	-	2,818
Form Liner Textured Surface	Sq. Ft.	-	3,022	3,022
Rubbed Finish	Sq. Ft.	-	895	895
Protective Coat	Sq. Yd.	3,483	-	3,483
Furnishing and Erecting Structural Steel	L. Sum	0.6	-	0.6
Stud Shear Connectors	Each	10,344	-	10,344
Reinforcement Bars	Pound	-	217,790	217,790
Reinforcement Bars, Epoxy Coated	Pound	213,630	119,290	332,920
Bar Splicers	Each	1,657	278	1,935
Mechanical Splicers	Each	-	363	363
Slopedwall 4 Inch	Sq. Yd.	-	164	164
Name Plates	Each	1	-	1
Drilled Shaft in Soil	Cu. Yd.	-	1,076	1,076
Drilled Shaft in Rock	Cu. Yd.	-	31	31
Preformed Joint Strip Seal	Foot	52	-	52
Elastomeric Bearing Assembly, Type II	Each	-	16	16
Anchor Bolts, 1"	Each	-	80	80
Anchor Bolts, 1 1/4"	Each	-	16	16
Temporary Soil Retention System	Sq. Ft.	-	153	153
Concrete Sealer	Sq. Ft.	-	8,327	8,327
Geocomposite Wall Drain	Sq. Yd.	-	79	79
Crosshole Sonic Logging	Each	-	4	4
Temporary Drainage System No. 1	L. Sum	1	-	1
Concrete Wearing Surface, 5"	Sq. Yd.	175	-	175
Precast Bridge Approach Slab	Sq. Ft.	1,568	-	1,568
High Load Multi-Rotational Bearing, Guided Expansion, 400k	Each	16	-	16
Granular Backfill for Structures	Cu. Yd.	-	180	180
Drainage Scuppers, DS-II	Each	9	-	9
Drainage System	L. Sum	0.2	-	0.2
Pipe Underdrains for Structures 4"	Foot	-	77	77
Temporary Shoring	Each	-	5	5

STRUCTURAL ASSESSMENT OF EXISTING STRUCTURE NOTES (Cont'd):

- Inventory and Operating Ratings and Live Load Restrictions are provided for information only. Inventory and Operating Ratings are based on HS loading and configuration. Live Load Restrictions are based on Illinois legal loads and configurations. The Ratings and Live load Restrictions are not necessarily representative of capacities to support the Contractor's equipment.
- The contractor is advised that the existing structures may contain members in deteriorated conditions with reduced load carrying capacities. It is the Contractor's responsibility to account for the condition of existing structures when developing construction procedures for using them to support construction loads.
- The contractor shall verify that the structural demands of the applied loads due to the Contractor's means and methods will not exceed the available capacity of the structure at the time loads are applied. Most likely, the Contractor will be required to provide additional shoring under the existing bridges (or other methods of retrofitting) to support construction loads. Design, installation and subsequent removal of such shoring system will be the responsibility of the Contractor and will not be paid separately.
- The Contractor shall use caution and not damage any component of the existing structure. Upon completion of work and prior to allowing traffic back on the existing structure the contractor must restore existing structure in its original condition.

STATION 5216+26.28
SECTION 2014-004R&B
BUILT BY
STATE OF ILLINOIS
F.A.I. ROUTE 90/94/290
LOADING HL-93
STRUCTURE NO. 016-1703

NAME PLATE
See Std. 515001

0161703-60X78-5002-1NX.dgn

PARSONS BRINCKERHOFF	USER NAME = pateld	DESIGNED - PJL	REVISED -	STATE OF ILLINOIS DEPARTMENT OF TRANSPORTATION	GENERAL DATA I STRUCTURE NO. 016-1703	F.A.I. RTE.	SECTION	COUNTY	TOTAL SHEETS	SHEET NO.
	PLOT SCALE = N.T.S.	CHECKED - JZ	REVISED -			90/94/290	2014-004 R&B	COOK	706	187
	PLOT DATE = 5/6/2016	DRAWN - DCP	REVISED -			CONTRACT NO. 60X78				
		CHECKED - JIG	REVISED -			ILLINOIS FED. AID PROJECT				

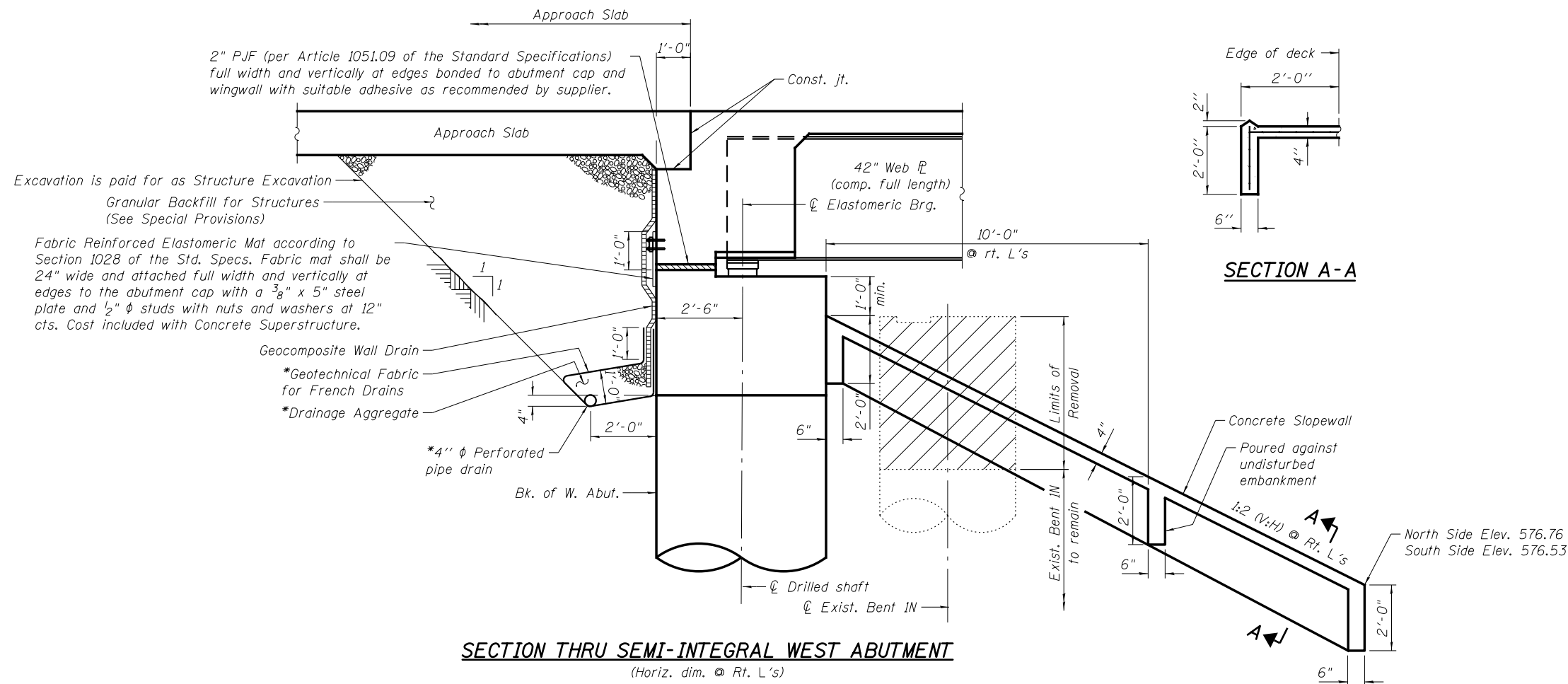

SECTION THRU SEMI-INTEGRAL WEST ABUTMENT
(Horiz. dim. @ Rt. L's)

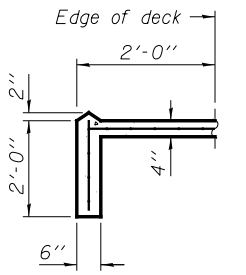

SECTION A-A

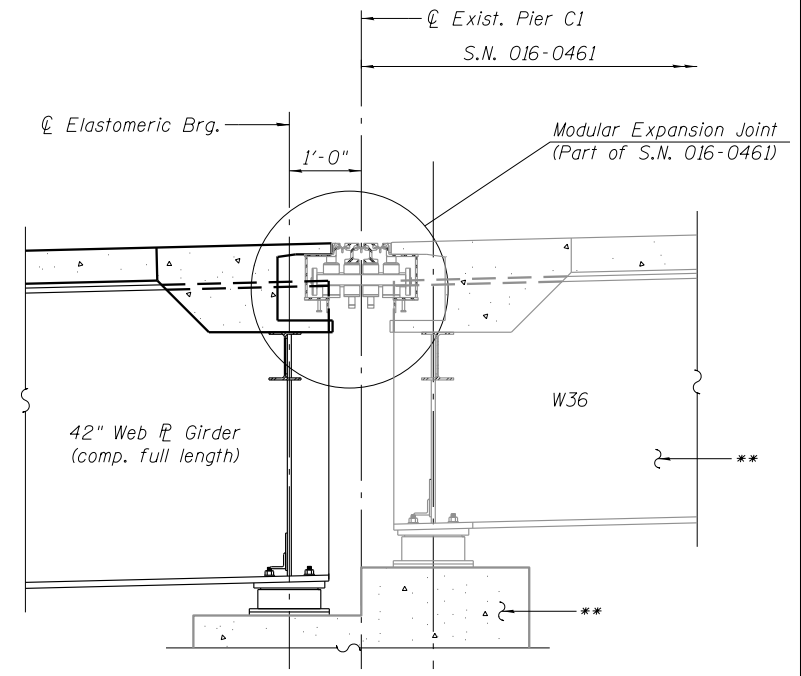

SECTION THRU PIER C1
(Horiz. dim. @ Rt. L's @ Pier C1)

** Construction of pier C1 is part of S.N. 016-0461 prior to construction of S.N. 016-1703.

* Included in the cost of Pipe Underdrains for Structures.

Notes:
 All drainage system components shall extend to 2'-0" from the end of each wingwall except an outlet pipe shall extend until intersecting with the side slopes. The pipes shall drain into concrete headwalls. (See Article 601.05 of the Standard Specifications and Highway Standard 601101).
 Bent cap of existing Bent IN shall be maintained during Stage I Construction.
 Concrete slopewall to be constructed during Stage II Construction.
 Slope wall shall be reinforced with welded wire fabric, 6 in. x 6 in. W4.0 x W4.0, weighing 58 lbs. per 100 sq. ft.

BILL OF MATERIAL

Item	Unit	Quantity
Slopewall 4 Inch	Sq. Yd.	164
Geocomposite Wall Drain	Sq. Yd.	79
Pipe Underdrains for Structures 4"	Foot	77
Granular Backfill for Structures	Cu. Yd.	180

0161703-60X78-5003-DET.dgn

PARSONS BRINCKERHOFF

USER NAME = pateld	DESIGNED - JZ	REVISED -
PLOT SCALE = N.T.S.	CHECKED - JZ	REVISED -
PLOT DATE = 5/6/2016	DRAWN - DCP	REVISED -
	CHECKED - JIG	REVISED -

**STATE OF ILLINOIS
DEPARTMENT OF TRANSPORTATION**

**GENERAL DATA II
STRUCTURE NO. 016-1703**

SHEET NO. S1-03 OF S1-53 SHEETS

F.A.I. RTE.	SECTION	COUNTY	TOTAL SHEETS	SHEET NO.
90/94/290	2014-004 R&B	COOK	706	188
CONTRACT NO. 60X78				
ILLINOIS FED. AID PROJECT				

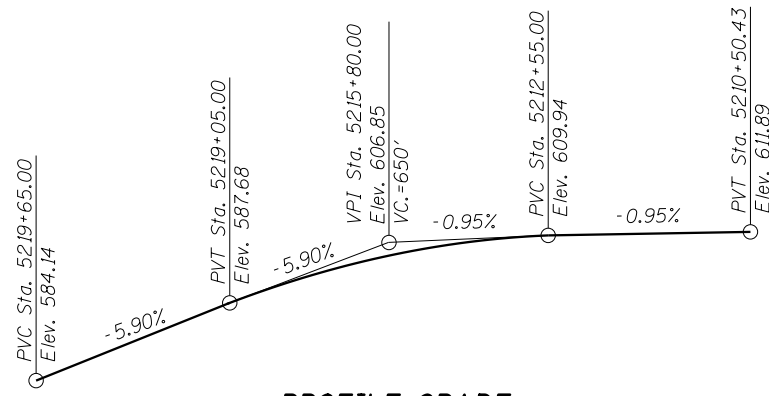

PROFILE GRADE
(Along WB I-290 (Congress))

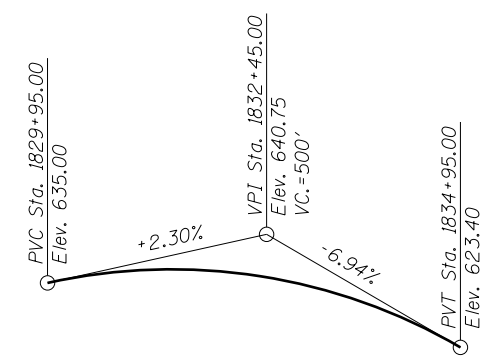

PROFILE GRADE
(Along Ramp NW)

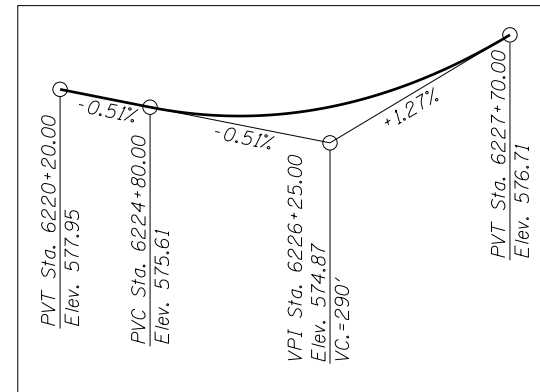

PROFILE GRADE
(Along SB I-90/94)

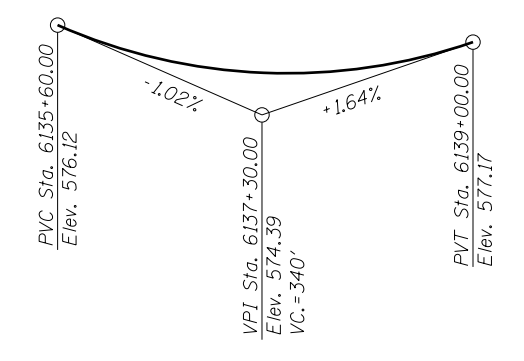

PROFILE GRADE
(Along NB I-90/94)

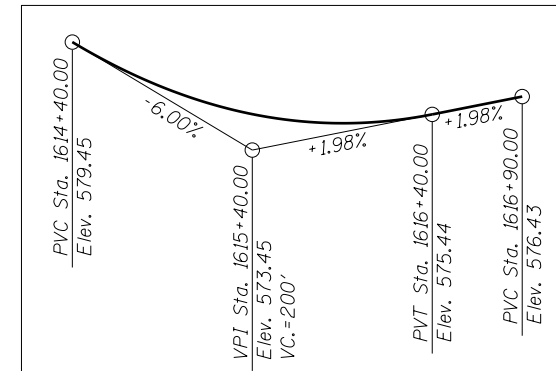

PROFILE GRADE
(Along Ramp EN)

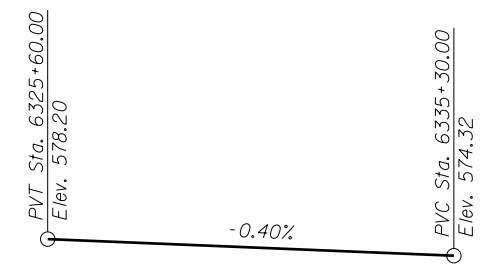

PROFILE GRADE
(Along NB Bypass)

CURVE DATA

(WB I-290)		(Ramp NW)	
PROP. CURVE P-CON-WB-1	PROP. CURVE P-CIR-NW-2	PROP. CURVE P-CON-WB-2	PROP. CURVE P-CIR-NW-6
PI Sta. = 5212+68.02	PI Sta. = 1831+44.22	PI Sta. = 5218+24.26	PI Sta. = 1831+44.22
$\Delta = 8^\circ 12' 18''$ (Rt.)	$\Delta = 88^\circ 30' 25''$ (Lt.)	$\Delta = 8^\circ 42' 22''$ (Lt.)	$\Delta = 88^\circ 30' 25''$ (Lt.)
$D = 3^\circ 30' 31''$	$D = 10^\circ 36' 37''$	$D = 3^\circ 29' 14''$	$D = 10^\circ 36' 37''$
$R = 1,633.00'$	$R = 540.00'$	$R = 1,643.00'$	$R = 540.00'$
$T = 117.13'$	$T = 526.11'$	$T = 125.07'$	$T = 526.11'$
$L = 233.85'$	$L = 834.16'$	$L = 249.65'$	$L = 834.16'$
$E = 4.20'$	$E = 213.92'$	$E = 4.75'$	$E = 213.92'$
$e = 4.40\%$	$e = 5.40\%$	$e = 4.40\%$	$e = 5.40\%$
$T.R. = 67'$	$T.R. = 39'$	$T.R. = NA$	$T.R. = 39'$
$S.E. Run = 147'$	$S.E. Run = 105'$	$S.E. Run = 97'$	$S.E. Run = 105'$
$P.C. Sta. = 5211+50.90$	$P.C. Sta. = 1826+18.11$	$P.C. Sta. = 5216+99.19$	$P.C. Sta. = 1826+18.11$
$P.T. Sta. = 5213+84.75$	$P.T. Sta. = 1834+52.27$	$P.T. Sta. = 5219+48.84$	$P.T. Sta. = 1834+52.27$
$DS = 45$	$DS = 35$	$DS = 45$	$DS = 35$

CURVE DATA

(SB I-90/94)
PROP. CURVE P-KDR-SB-3
PI Sta. = 6224+30.06
$\Delta = 11^\circ 28' 39''$ (Rt.)
$D = 2^\circ 41' 06''$
$R = 2,134.00'$
$T = 214.46'$
$L = 427.48'$
$E = 10.75'$
$e = 4.20\%$
$T.R. = NA$
$S.E. Run = 203'$
$P.C. Sta. = 6222+15.60$
$P.T. Sta. = 6226+43.08$
$DS = 60$

CURVE DATA

(Ramp EN)
PROP. CURVE P-CIR-EN-2
PI Sta. = 1624+72.31
$\Delta = 158^\circ 53' 11''$ (Lt.)
$D = 16^\circ 51' 06''$
$R = 340.00'$
$T = 1,824.37'$
$L = 942.85'$
$E = 1,515.78'$
$e = 5.60\%$
$T.R. = 36'$
$S.E. Run = 102'$
$P.C. Sta. = 1606+47.94$
$P.T. Sta. = 1615+90.79$
$DS = 30$

CURVE DATA

(NB Bypass)
PROP. CURVE P-NCD-NX-4
PI Sta. = 6328+76.78
$\Delta = 59^\circ 05' 41''$ (Lt.)
$D = 14^\circ 08' 50''$
$R = 405.00'$
$T = 229.58'$
$L = 417.72'$
$E = 60.54'$
$e = 5.40\%$
$T.R. = 36'$
$S.E. Run = 98'$
$P.C. Sta. = 6326+47.20$
$P.T. Sta. = 6330+64.91$
$DS = 30$

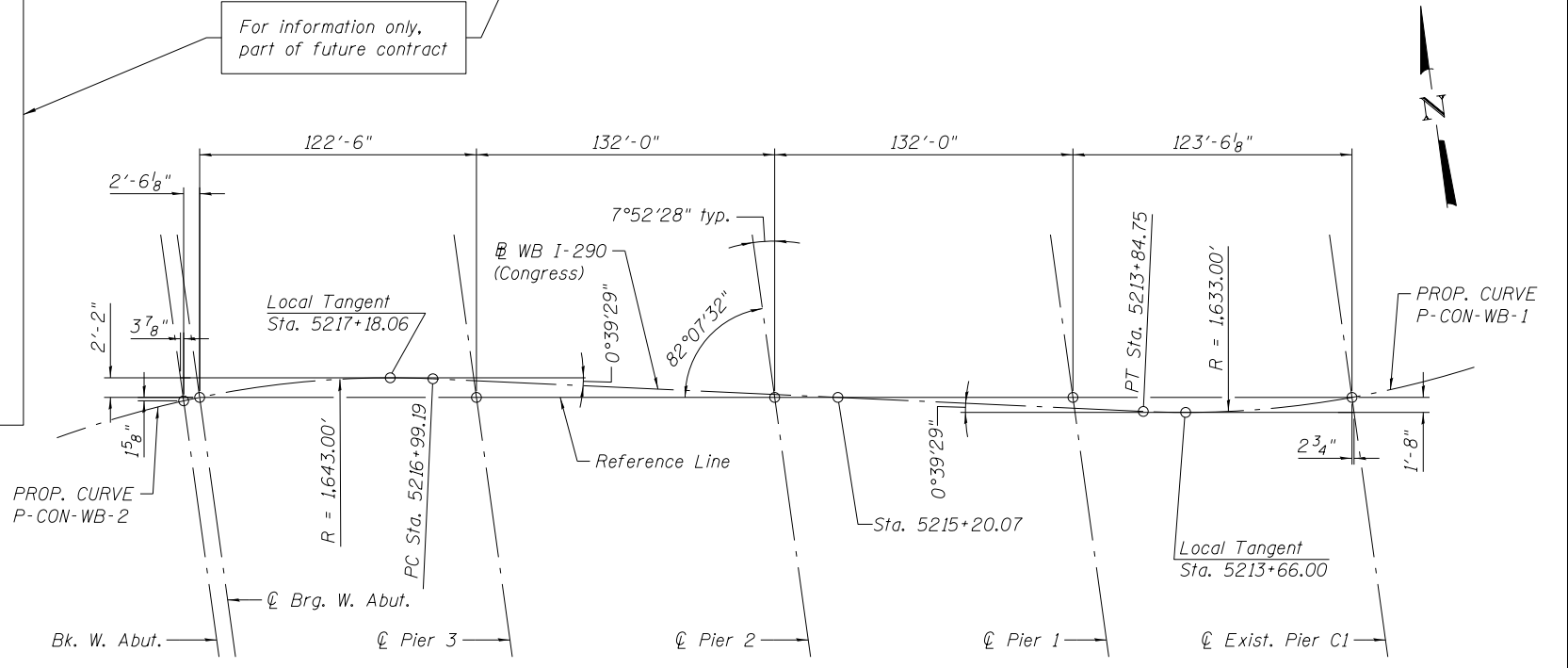

OFFSET SKETCH

0161703-60X78-5004-PGL.dgn



USER NAME = pateld	DESIGNED - PJL	REVISED -
PLOT SCALE = N.T.S.	CHECKED - JZ	REVISED -
PLOT DATE = 3/23/2016	DRAWN - DCP	REVISED -
	CHECKED - JIG	REVISED -

STATE OF ILLINOIS
DEPARTMENT OF TRANSPORTATION

CURVE DATA & GEOMETRIC LAYOUT
STRUCTURE NO. 016-1703

SHEET NO. S1-04 OF S1-53 SHEETS

F.A.I. RTE.	SECTION	COUNTY	TOTAL SHEETS	SHEET NO.
90/94/290	2014-004 R&B	COOK	706	189
CONTRACT NO. 60X78				
ILLINOIS FED. AID PROJECT				

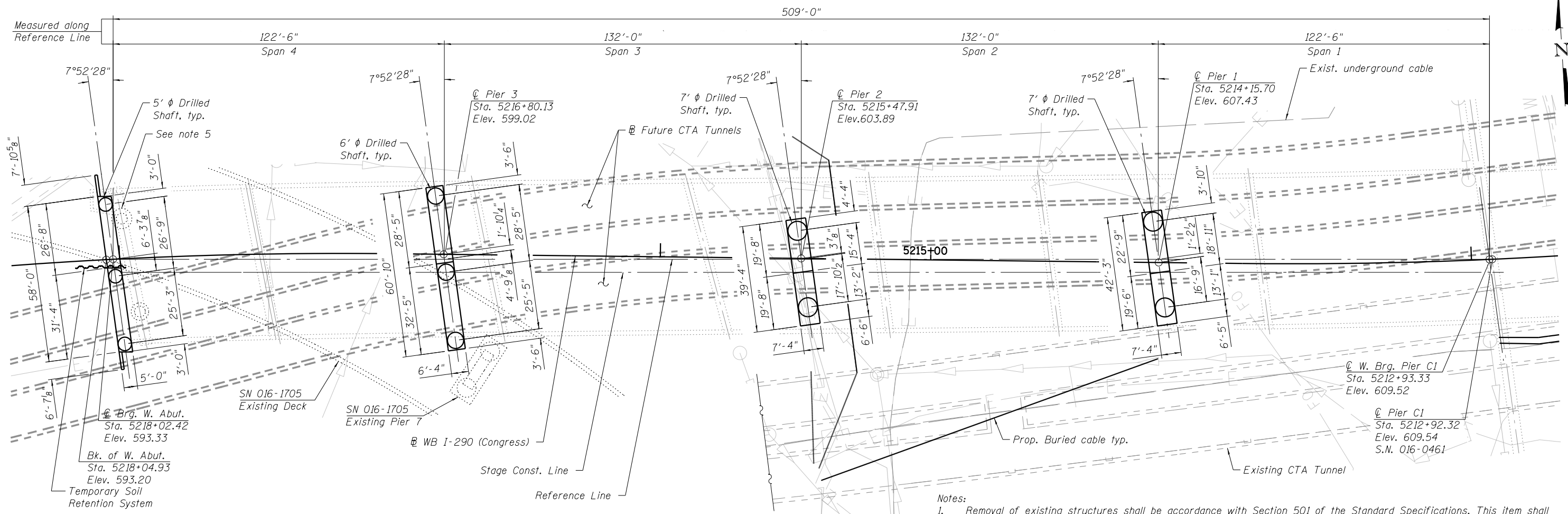

LEGEND:

- |W|— Water Line
- |E|— Electric
- |T|— Telephone line
- |CTV|— Television line
- |>>>|— Combined Sewer
- |>|— Storm Sewer

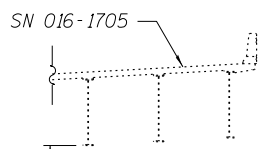
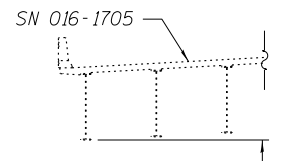

SUBSTRUCTURE LAYOUT PLAN

Notes:

1. Removal of existing structures shall be accordance with Section 501 of the Standard Specifications. This item shall include complete removal of the concrete bridge rails, concrete deck and superstructure. This item also includes partial removal of the abutment wall and wingwall down to a minimum of 1'-0" below proposed finished grade.
2. Impact driving of piles and sheet piling is not allowed.
3. The maximum allowable excavation slope is 1:2 (V:H).
4. For Temporary Soil Retention System limits, See sheet S1-6.
5. The Contractor shall perform a preconstruction survey at the west abutment identifying the clearance distance between the existing drilled shafts and proposed. Included within his Installation Procedure submittal the Contractor shall identify his proposed means and methods to prevent from encountering the existing drilled shafts during construction. No separate payment will be made for Work associated with encountering the existing drilled shafts which may be included but not be limited to the use of special augers, tooling, or core barrels and/or constructing a replacement drilled shaft. The cost for Work associated with encountering the existing drilled shafts shall be included in the cost of Drilled Shaft in Soil.

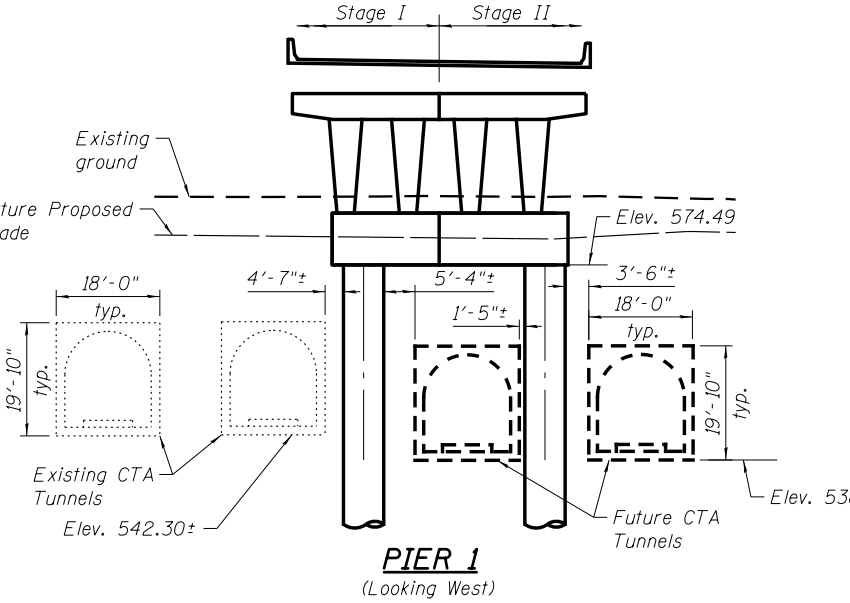
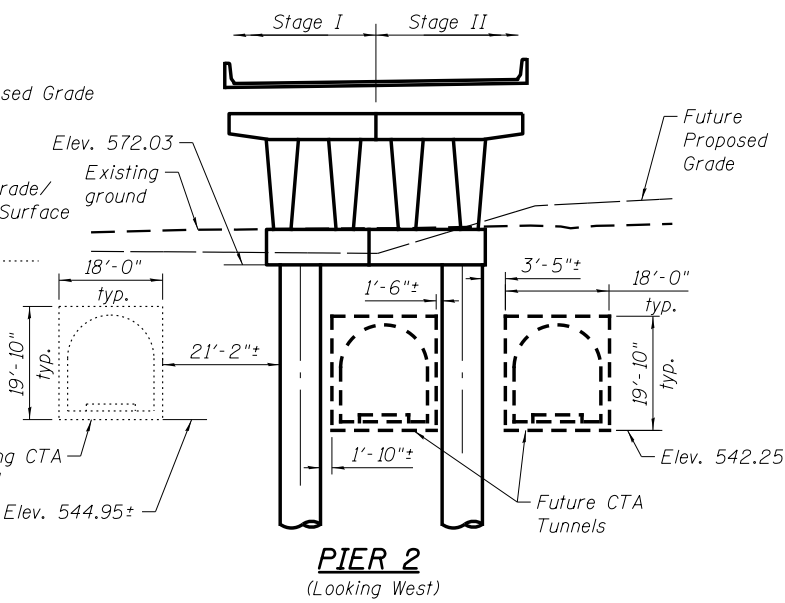
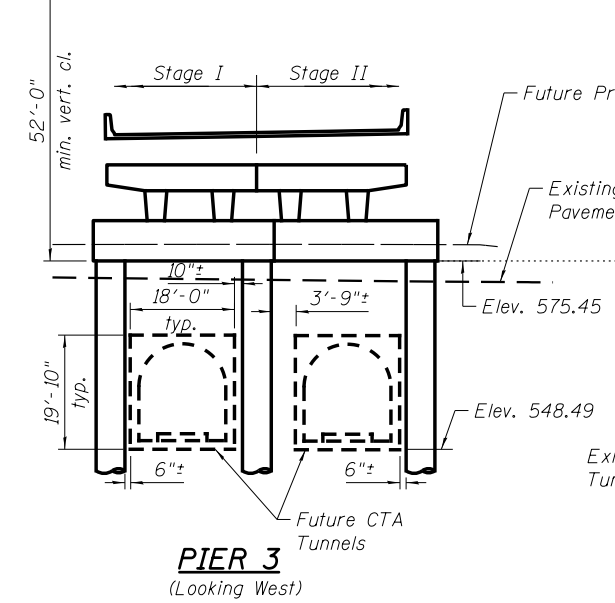
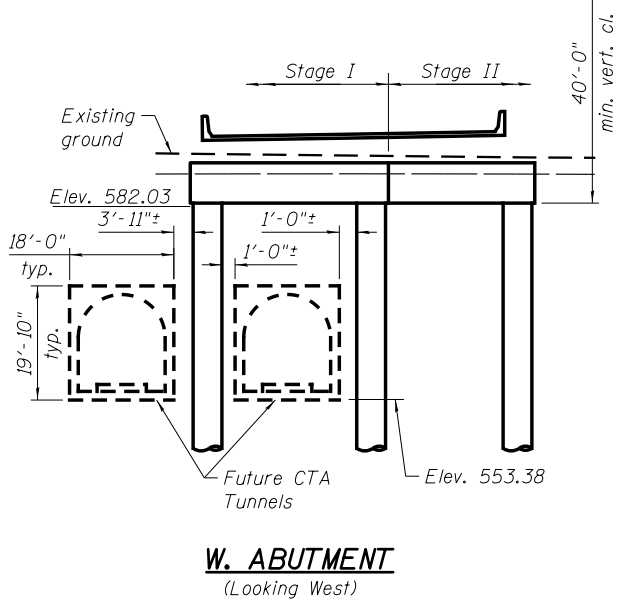

0161703-60X78-S005-LAY.dgn

PARSONS BRINCKERHOFF

USER NAME = pateld	DESIGNED - JZ	REVISD -
PLOT SCALE = N.T.S.	CHECKED - LFC	REVISD -
PLOT DATE = 5/9/2016	DRAWN - JZ	REVISD -
	CHECKED - JIG	REVISD -

**STATE OF ILLINOIS
DEPARTMENT OF TRANSPORTATION**

**SUBSTRUCTURE LAYOUT
STRUCTURE NO. 016-1703**

SHEET NO. S1-05 OF S1-53 SHEETS

F.A.I. RTE. 90/94/290	SECTION 2014-004 R&B	COUNTY COOK	TOTAL SHEETS 706	SHEET NO. 190
CONTRACT NO. 60X78				
ILLINOIS FED. AID PROJECT				

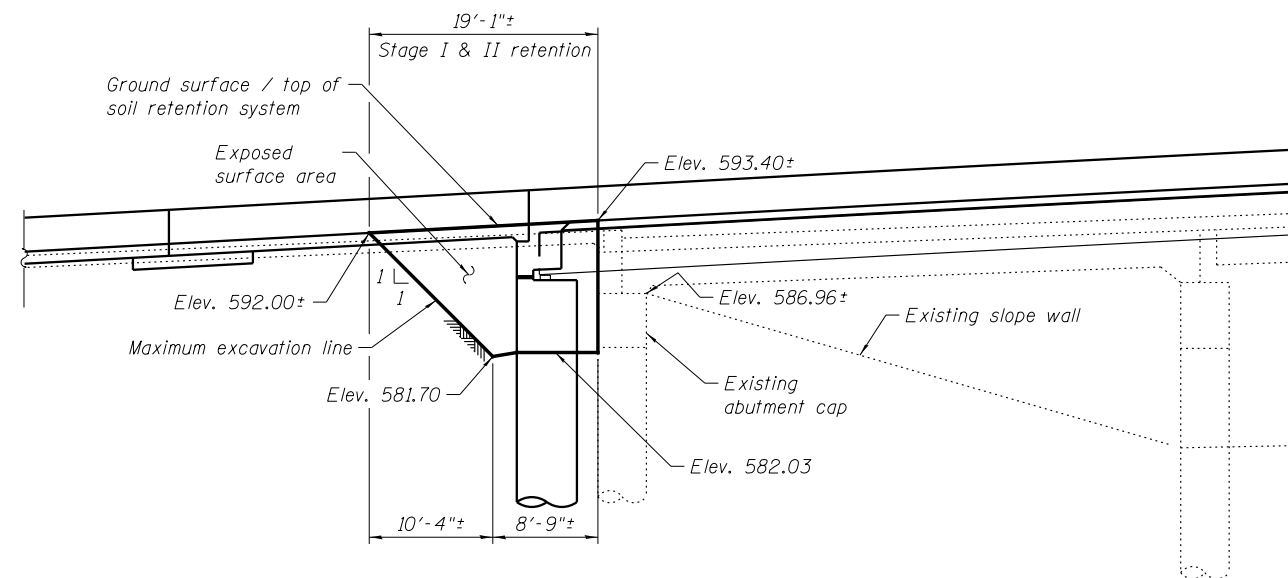

TEMPORARY SOIL RETENTION AT WEST ABUTMENT

(Dimensions measured along Stage Construction Line)

BILL OF MATERIAL

Item	Unit	Quantity
Temporary Soil Retention System	Sq. Ft.	153

Notes:

- Impact driving of piles and sheet piling is not allowed.
- A cantilevered sheet piling design does not appear feasible and additional members or other retention systems may be necessary. The Contractor shall submit a temporary soil retention system design including plan details and calculations for review and acceptance by the Engineer.
- Coordinate T.S.R.S. placement with deck demolition and existing beam locations.
- Slope at top of soil retention system to match slope of existing slope wall.

0161703-60X78-5006-SRS.dgn

**PARSONS
BRINCKERHOFF**

USER NAME = pateld	DESIGNED - JZ	REVISED -
	CHECKED - LFC	REVISED -
PLOT SCALE = N.T.S.	DRAWN - JZ	REVISED -
PLOT DATE = 3/23/2016	CHECKED - JIG	REVISED -

**STATE OF ILLINOIS
DEPARTMENT OF TRANSPORTATION**

**TEMPORARY SOIL RETENTION SYSTEM
STRUCTURE NO. 016-1703**

SHEET NO. S1-06 OF S1-53 SHEETS

F.A.I. RTE.	SECTION	COUNTY	TOTAL SHEETS	SHEET NO.
90/94/290	2014-004 R&B	COOK	706	191
CONTRACT NO. 60X78				
ILLINOIS FED. AID PROJECT				

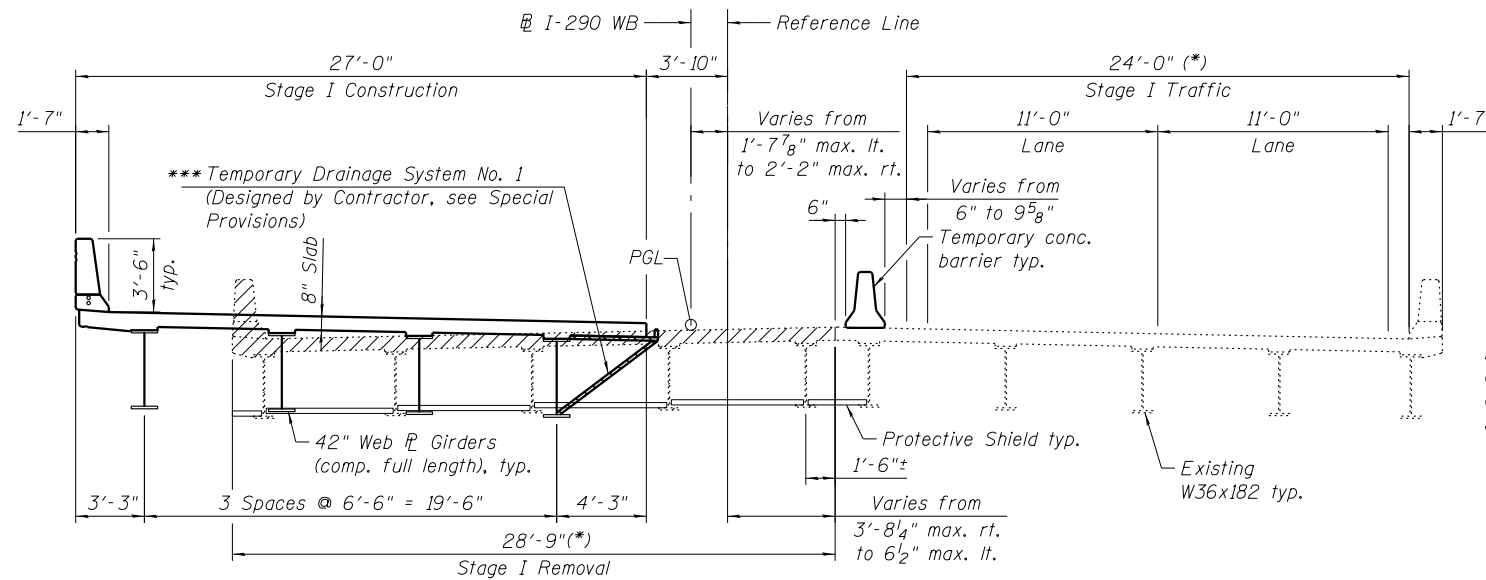

CROSS SECTION EXCLUDING WEST END - STAGE I

(Looking West) Upstation, Sta. 5212+92.36 to 5217+48.08
 (Dimensions are measured perpendicular to Reference Line U.N.O.)

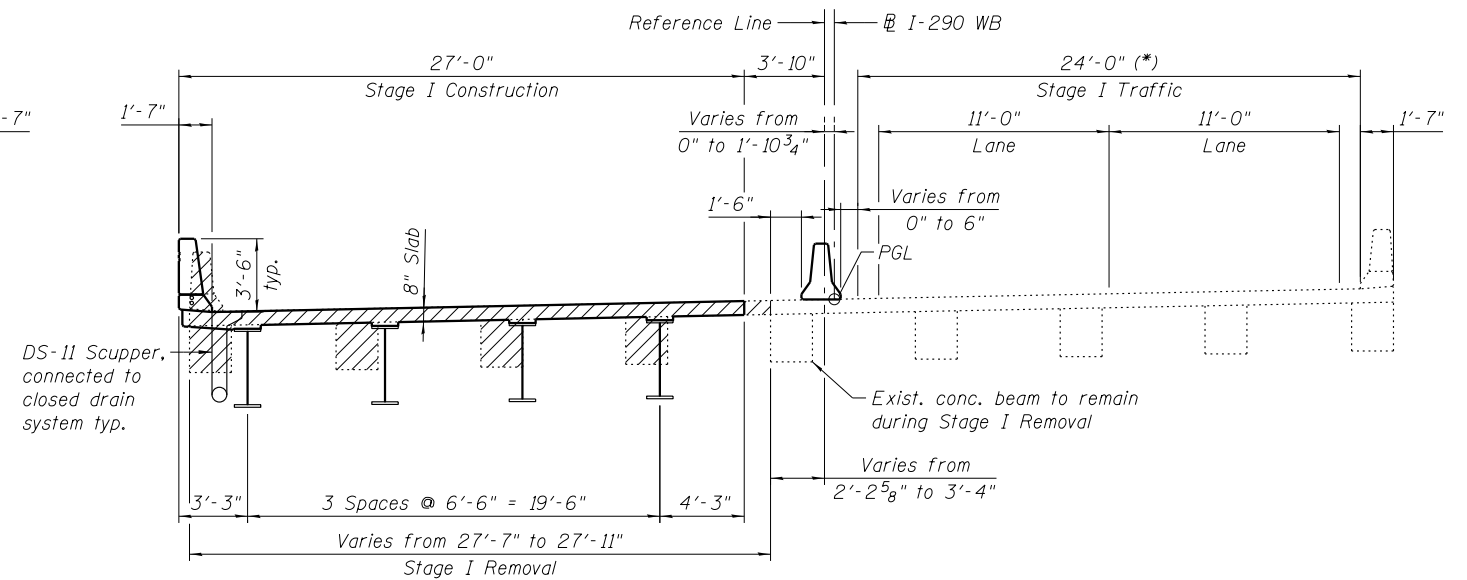

CROSS SECTION AT WEST END - STAGE I

(Looking West) Upstation, Sta. 5217+48.08 to 5218+03.95
 (Dimensions are measured perpendicular to Reference Line U.N.O.)

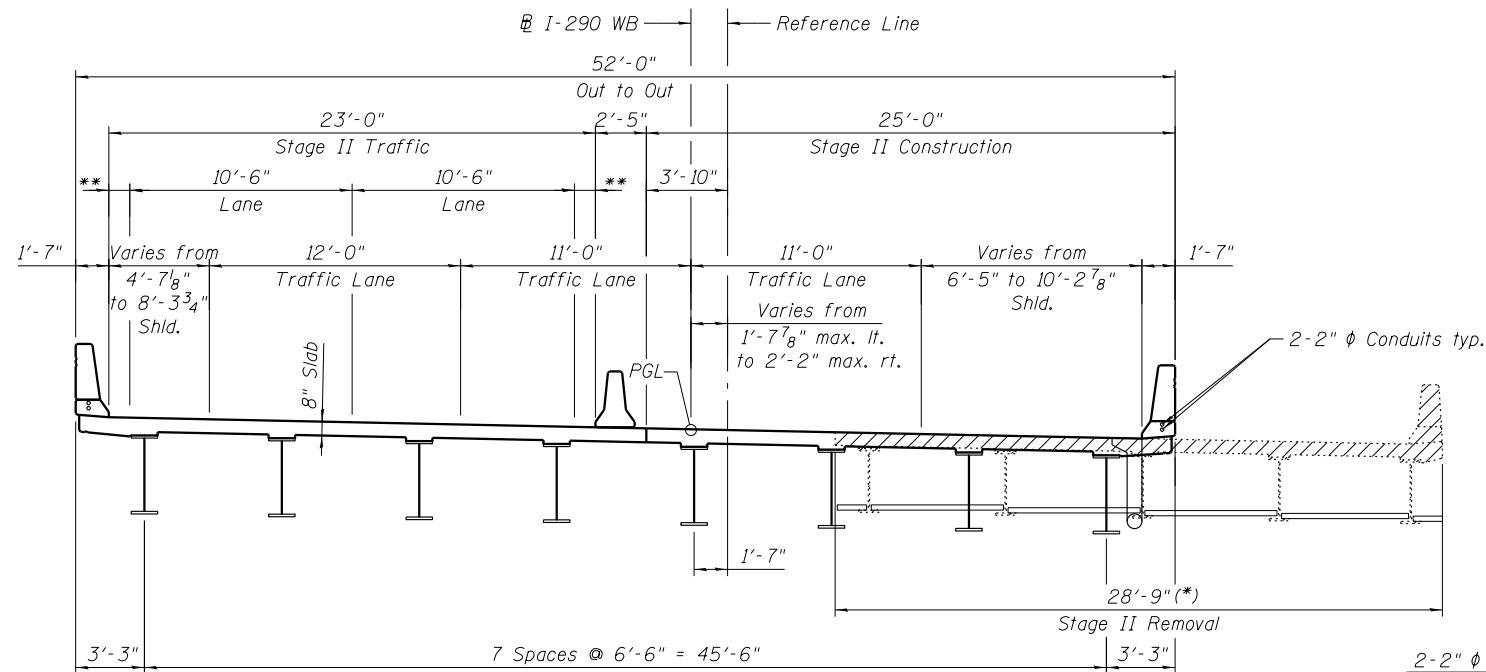

CROSS SECTION EXCLUDING WEST END - STAGE II

(Looking West) Upstation, Sta. 5212+92.36 to 5217+48.08
 (Dimensions are measured perpendicular to Reference Line U.N.O.)

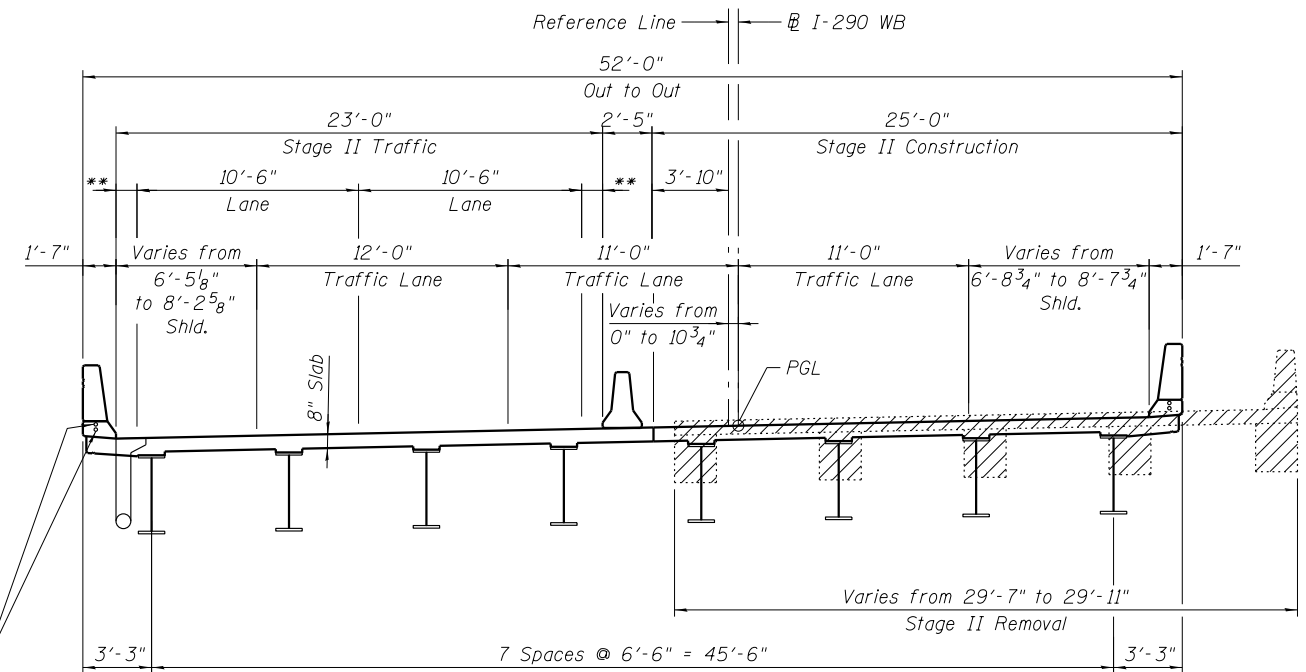

CROSS SECTION AT WEST END - STAGE II

(Looking West) Upstation, Sta. 5217+48.08 to 5218+03.95
 (Dimensions are measured perpendicular to Reference Line U.N.O.)

* Exist. deck width is measured perpendicular to exist. \perp .

** Varies from 0' - 1'-6"

*** Minimum cross-sectional area of
 Temporary Drainage System = 0.33 Sq. Ft.

BILL OF MATERIAL

Item	Unit	Total
Temporary Drainage System No. 1	L. Sum	1

Notes:

- Hatched areas indicate removal of existing structure.
- See sheet S1-11, for details of Temporary Concrete Barrier
- For quantity of Temporary Concrete Barrier, see Roadway Plans.

0161703-60X78-S007-STC.dgn

**PARSONS
BRINCKERHOFF**

USER NAME = pateld	DESIGNED - P.JL	REVISED -
PLOT SCALE = N.T.S.	CHECKED - J.Z	REVISED -
PLOT DATE = 3/23/2016	DRAWN - D.CP	REVISED -
	CHECKED - J.JG	REVISED -

**STATE OF ILLINOIS
DEPARTMENT OF TRANSPORTATION**

**STAGE CONSTRUCTION DETAILS
STRUCTURE NO. 016-1703**

SHEET NO. S1-07 OF S1-53 SHEETS

F.A.I. RTE.	SECTION	COUNTY	TOTAL SHEETS	SHEET NO.
90/94/290	2014-004 R&B	COOK	706	192
CONTRACT NO. 60X78			ILLINOIS FED. AID PROJECT	

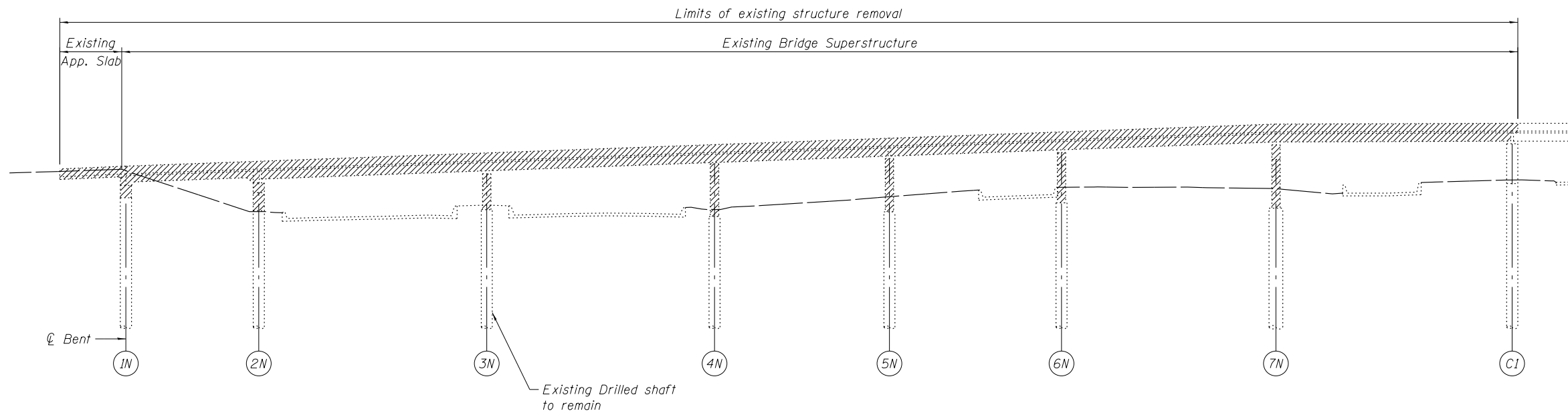

ELEVATION

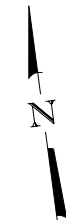
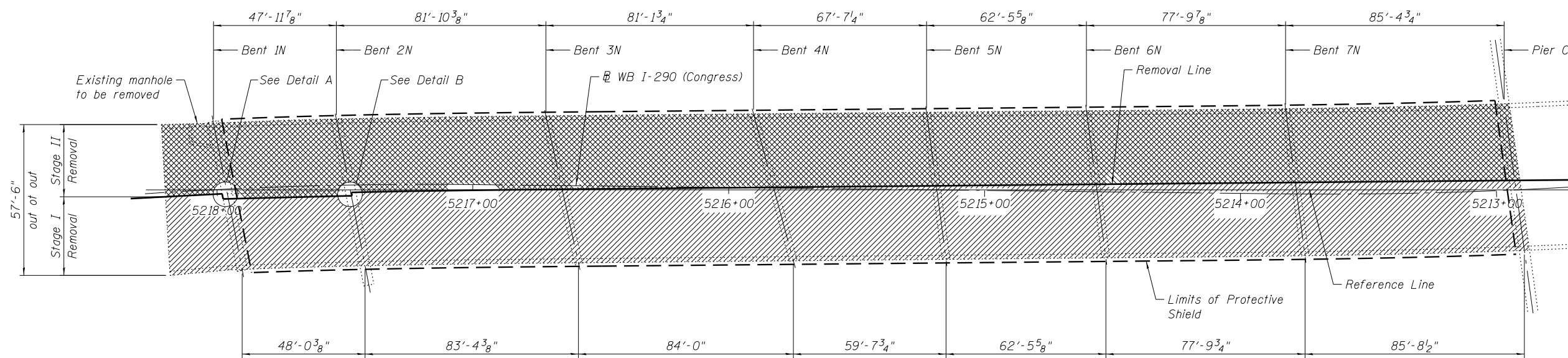

LEGEND:

- Stage I Removal
- Stage II Removal
- Limits of Protective Shield

BILL OF MATERIAL

Item	Unit	Quantity
Removal of Existing Structures No. 1	Each	1
Protective Shield	Sq Yd	3,222

Notes:

1. See sheet S1-9 & S1-10, for substructure removal.
2. See sheet S1-7, for superstructure removal.

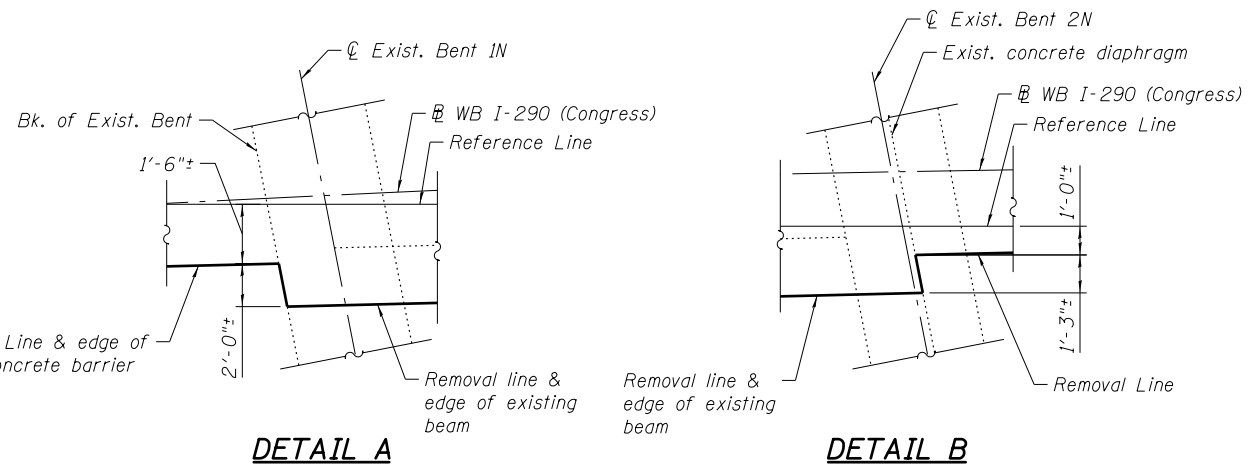

DETAIL A

DETAIL B

PLAN

0161703-60X78-5008-ESR.dgn

PARSONS BRINCKERHOFF

USER NAME = pateld	DESIGNED - JLP	REVISED -
	CHECKED - LFC	REVISED -
PLOT SCALE = N.T.S.	DRAWN - DCP	REVISED -
PLOT DATE = 3/23/2016	CHECKED - JIG	REVISED -

**STATE OF ILLINOIS
DEPARTMENT OF TRANSPORTATION**

**EXISTING STRUCTURE REMOVAL DETAILS I
STRUCTURE NO. 016-1703**

SHEET NO. S1-08 OF S1-53 SHEETS

F.A.I. RTE.	SECTION	COUNTY	TOTAL SHEETS	SHEET NO.
90/94/290	2014-004 R&B	COOK	706	193
CONTRACT NO. 60X78				
<small>ILLINOIS FED. AID PROJECT</small>				

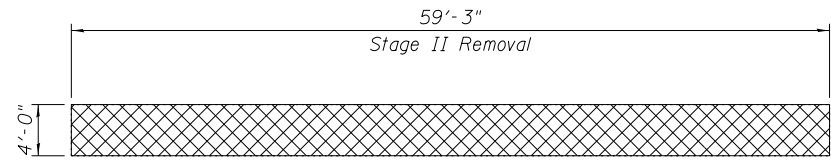

BENT 1N PLAN

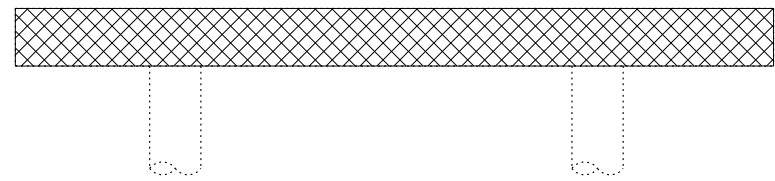

BENT 1N ELEVATION

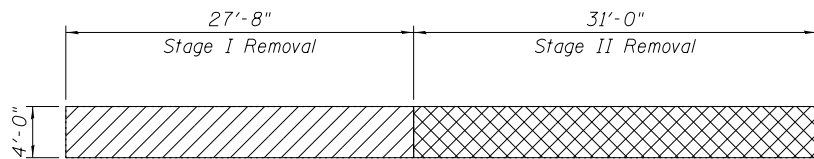

BENT 2N PLAN

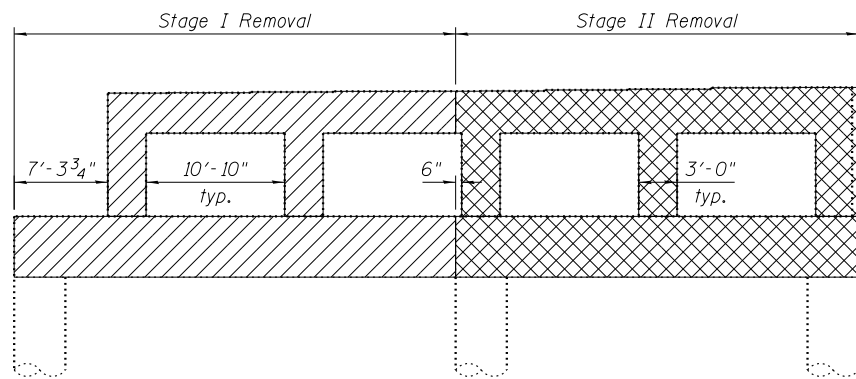

BENT 2N ELEVATION

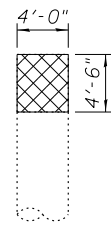
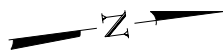

END VIEW

* Existing Pier 7 part of S.N. 016-1705

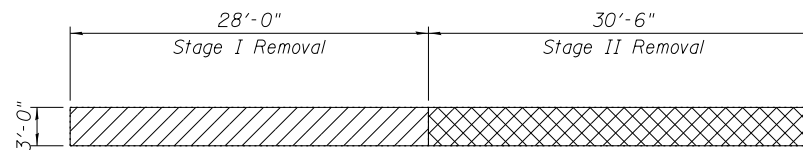
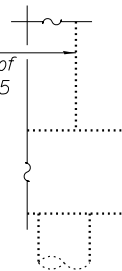

BENT 3N PLAN

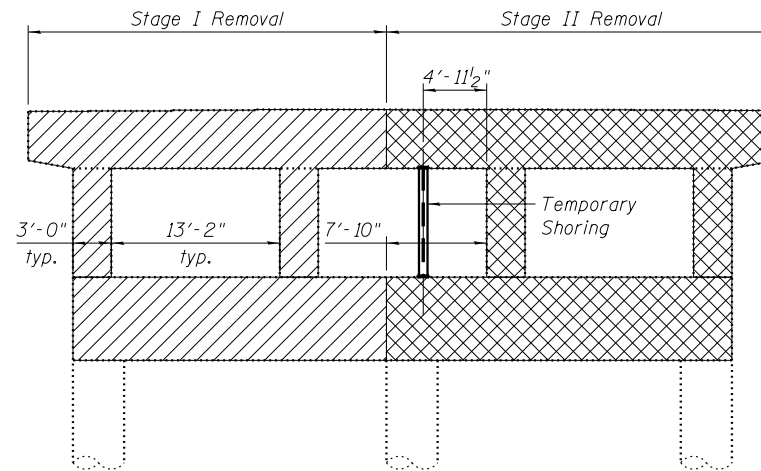

BENT 3N ELEVATION

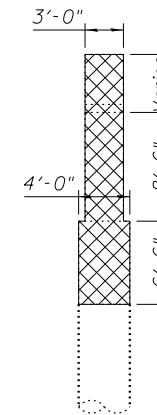

END VIEW

* Contractor shall take all necessary precautions to protect and not undermine near by existing Pier 7 foundation part of S.N. 016-1705.

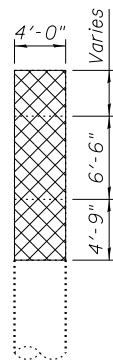
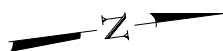

END VIEW

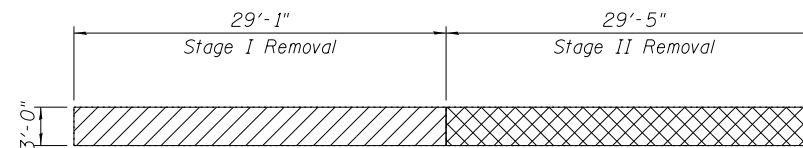

BENT 4N PLAN

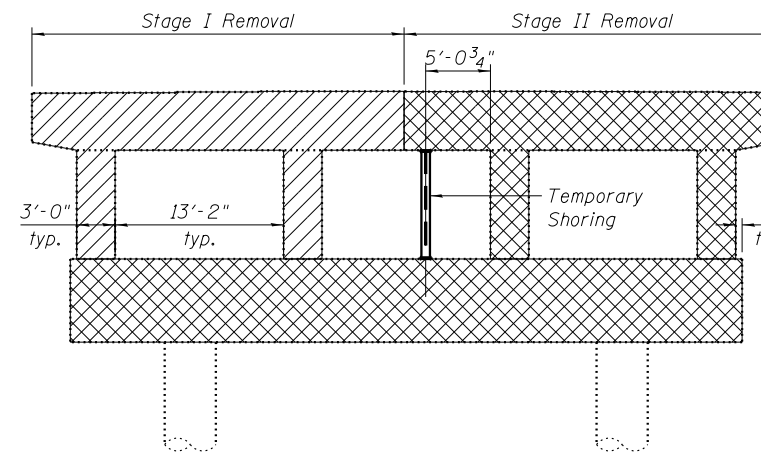

BENT 4N ELEVATION

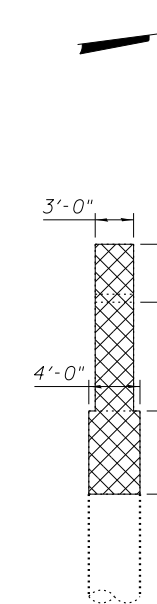

END VIEW

Note: Temporary shoring shall be placed at the bearing of exterior girder.

Service temporary shoring design load at each bent:
DL: 126 k
LL: 63 k

LEGEND:

- Stage I Removal
- Stage II Removal

0161703-60X78-5009-ESR.dgn

PARSONS BRINCKERHOFF

USER NAME = pateld	DESIGNED - JZ	REVISED -
	CHECKED - LFC	REVISED -
PLOT SCALE = N.T.S.	DRAWN - DCP	REVISED -
PLOT DATE = 3/23/2016	CHECKED - JIG	REVISED -

**STATE OF ILLINOIS
DEPARTMENT OF TRANSPORTATION**

**EXISTING STRUCTURE REMOVAL DETAILS II
STRUCTURE NO. 016-1703**

SHEET NO. S1-09 OF S1-53 SHEETS

F.A.I. RTE.	SECTION	COUNTY	TOTAL SHEETS	SHEET NO.
90/94/290	2014-004 R&B	COOK	706	194
CONTRACT NO. 60X78				
ILLINOIS FED. AID PROJECT				

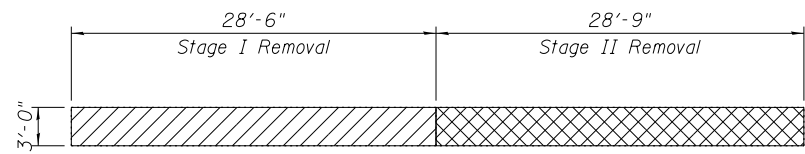

BENT 5N PLAN

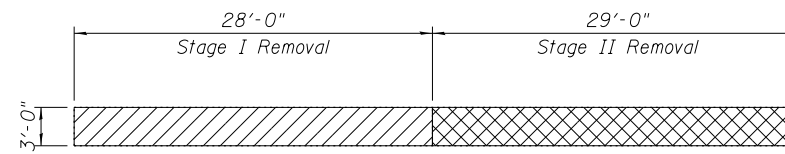
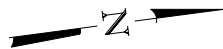

BENT 7N PLAN

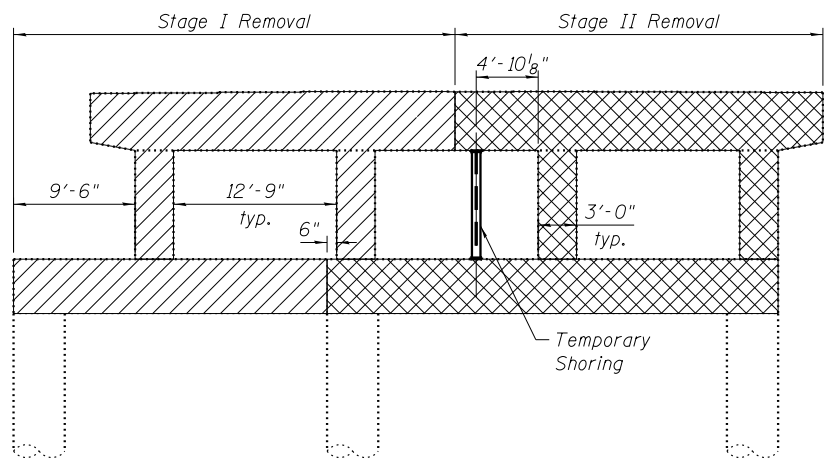

BENT 5N ELEVATION

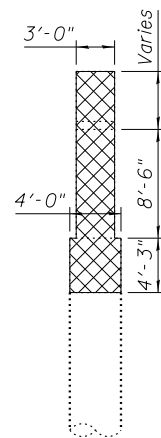

END VIEW

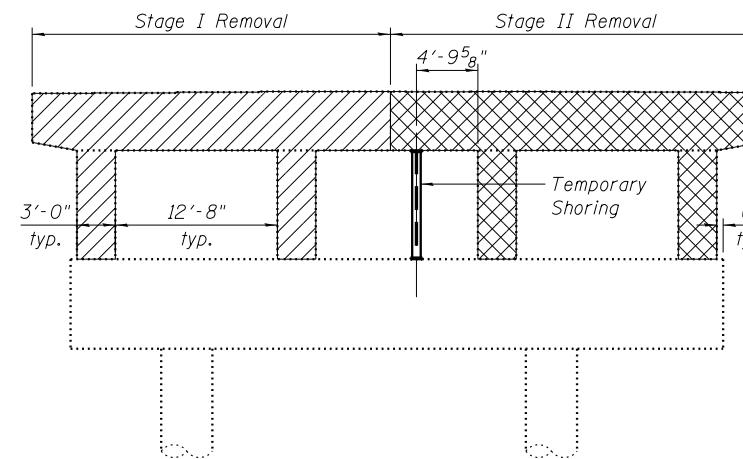

BENT 7N ELEVATION

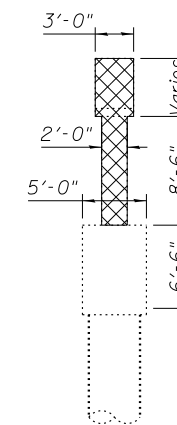

END VIEW

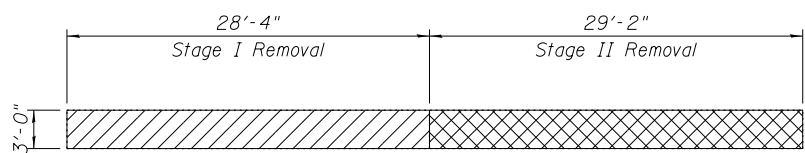

PIER 6N PLAN

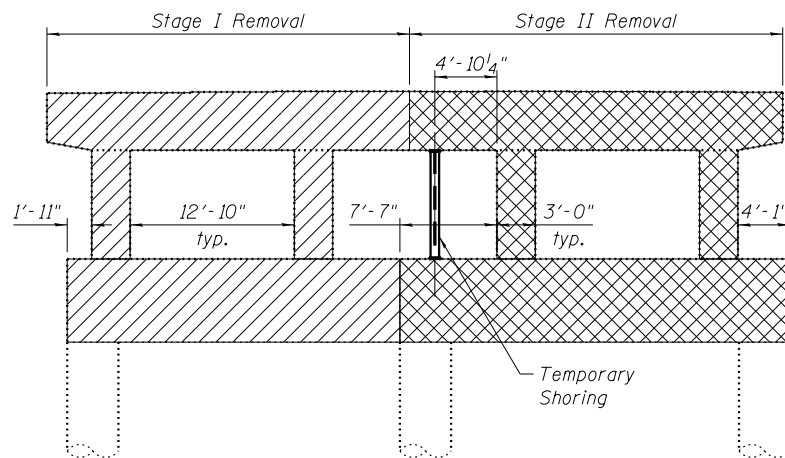
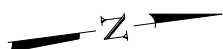

BENT 6N ELEVATION

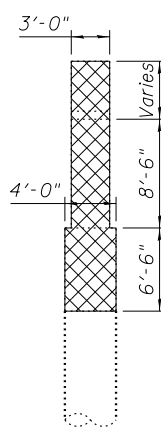

END VIEW

Note:
Temporary shoring shall be placed at the ϕ bearing of exterior girder.

Service temporary shoring design load at each bent:
DL: 126 k
LL: 63 k

BILL OF MATERIAL

Item	Unit	Quantity
Temporary Shoring	Each	5

LEGEND:

- Stage I Removal
- Stage II Removal

0161703-60X78-S010-ESR.dgn

**PARSONS
BRINCKERHOFF**

USER NAME = pateld	DESIGNED - JZ	REVISED -
PLOT SCALE = N.T.S.	CHECKED - LFC	REVISED -
PLOT DATE = 3/23/2016	DRAWN - DCP	REVISED -
	CHECKED - JIG	REVISED -

**STATE OF ILLINOIS
DEPARTMENT OF TRANSPORTATION**

**EXISTING STRUCTURE REMOVAL DETAILS III
STRUCTURE NO. 016-1703**

SHEET NO. S1-10 OF S1-53 SHEETS

F.A.I. RTE.	SECTION	COUNTY	TOTAL SHEETS	SHEET NO.
90/94/290	2014-004 R&B	COOK	706	195
CONTRACT NO. 60X78				
ILLINOIS FED. AID PROJECT				

When "A" is 3'-1" or less, the temporary concrete barrier shall be anchored to the new slab according to Detail I or Detail II. No anchorage is required when "A" is greater than 3'-1".

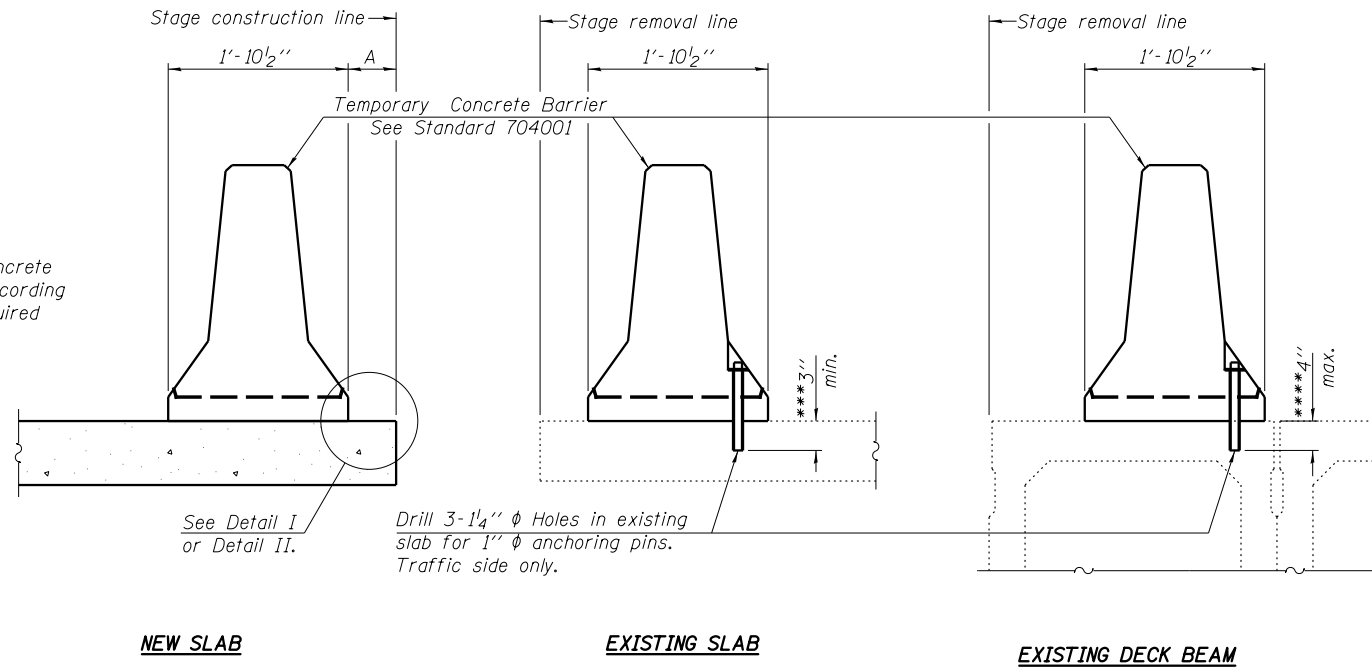

SECTIONS THRU SLAB OR DECK BEAM

NOTES

Detail I - With Bar Splicer or Couplers:
Connect one (1) 1" x 7" x "W" steel PL to the top layer of couplers with 2-5/8" φ bolts screwed to coupler at approximate C of each barrier panel.

Detail II - With Extended Reinforcement Bars:
Connect one (1) 1" x 7" x "W" steel PL to the concrete slab or concrete wearing surface with 2-5/8" φ Expansion Anchors or cast in place inserts spaced between the top layer of reinforcement at approximate C of each barrier panel.

Cost of retainer assembly is included with Temporary Concrete Barrier. The 1" x 7" x "W" plate shall not be removed until stage II construction forms and all reinforcement bars are in place and the concrete is ready to be placed.

*** Dimension shown is minimum required embedment into concrete. If hot-mix asphalt wearing surface is present, minimum embedment shall be in addition to wearing surface depth.

**** If existing deck beam is to remain in place after stage construction, embedment shall only be into wearing surface and not into existing deck beam concrete.

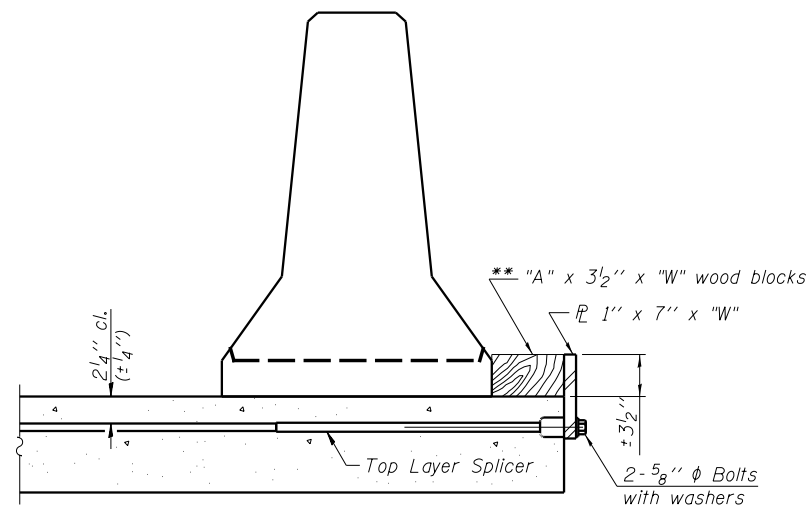

DETAIL I

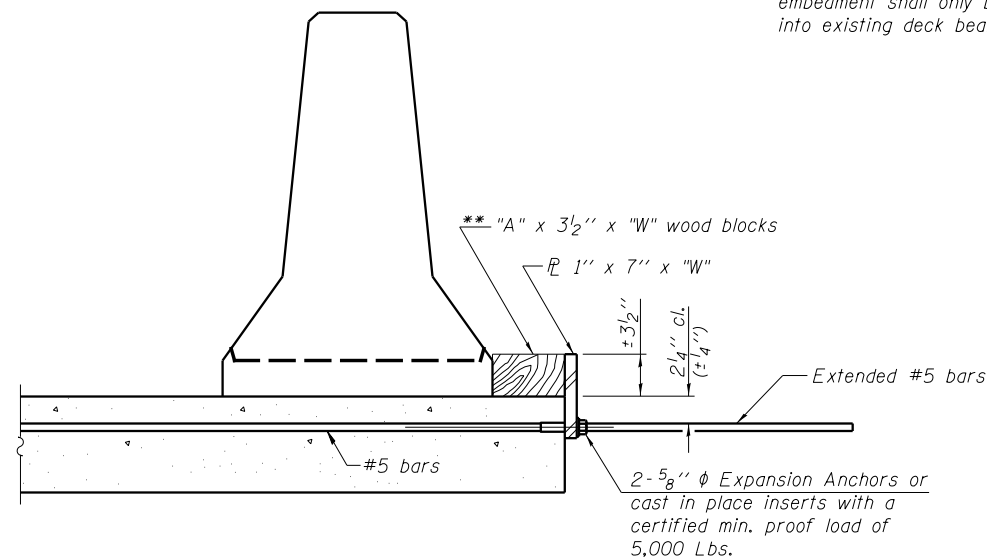

DETAIL II

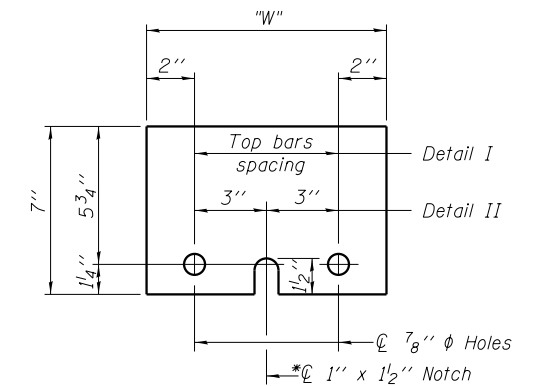

STEEL RETAINER PL 1" x 7" x "W"

* Required only with Detail II

RETAINER ASSEMBLY

** Wood blocks may be omitted when required to provide minimum stage traffic lane width. When the wood blocks are omitted, the concrete barrier shall be in direct contact with the steel retainer plate.

R-27

1-12-15

PARSONS BRINCKERHOFF

USER NAME = pateld	DESIGNED - JZ	REVISED -
PLOT SCALE = N.T.S.	CHECKED - AH	REVISED -
PLOT DATE = 3/23/2016	DRAWN - DCP	REVISED -
	CHECKED - JIG	REVISED -

**STATE OF ILLINOIS
DEPARTMENT OF TRANSPORTATION**

**TEMPORARY CONCRETE BARRIER FOR STAGE CONSTRUCTION
STRUCTURE NO. 016-1703**

SHEET NO. S1-11 OF S1-53 SHEETS

F.A.I. R.E.	SECTION	COUNTY	TOTAL SHEETS	SHEET NO.
90/94/290	2014-004 R&B	COOK	706	196
CONTRACT NO. 60X78				

ILLINOIS FED. AID PROJECT

0161703-60X78-S011-TCB.dgn

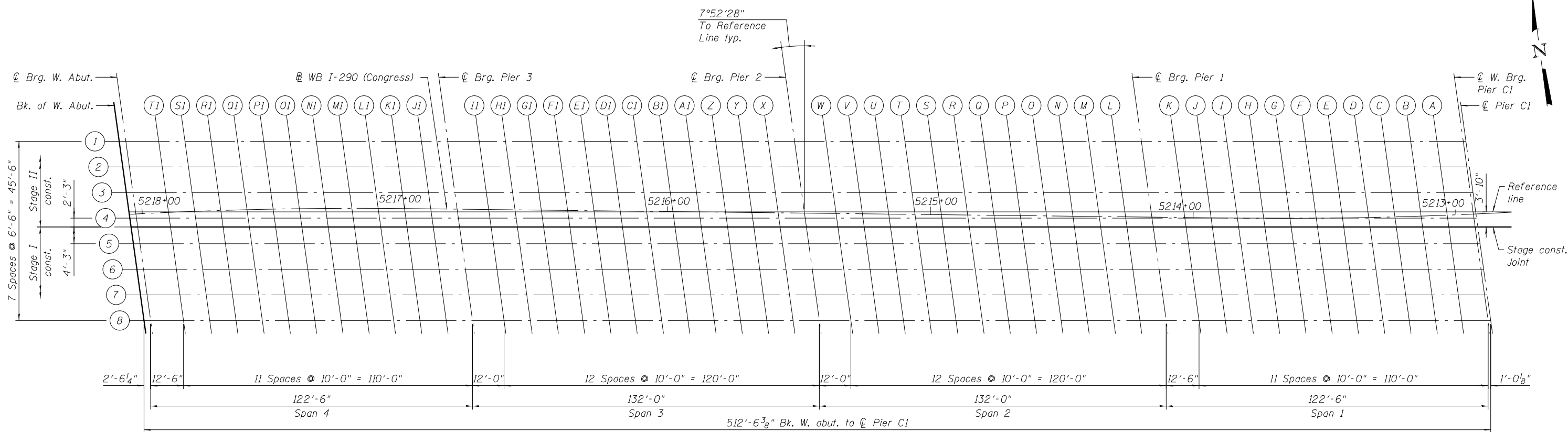

PLAN

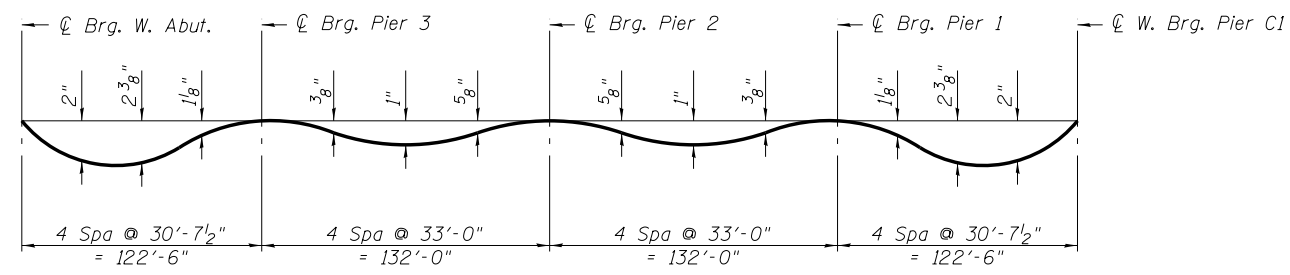

DEAD LOAD DEFLECTION DIAGRAM
(Includes weight of concrete only.)

Note:
The above deflections are not to be used in the field if the engineer is working from the grade elevations adjusted for dead load deflections as shown in tables. See sheets S1-13 thru S1-16.

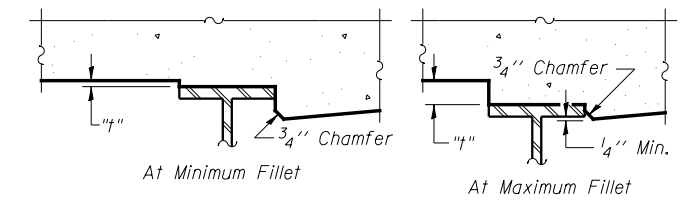

To determine "t": After all structural steel has been erected, elevations of the top flanges of the beams shall be taken at intervals in tables. See sheets S1-13 thru S1-16. These elevations subtracted from the "Theoretical Grade Elevations Adjusted for Dead Load Deflection" shown on sheets S1-13 thru S1-16, minus slab thickness, equals the fillet heights "t" above top flange of beams.

FILLET HEIGHTS

0161703-60X78-S012-TSE.dgn

PARSONS BRINCKERHOFF

USER NAME = pateld	DESIGNED - JLP/HA	REVISED -
PLOT SCALE = N.T.S.	CHECKED - JZ	REVISED -
PLOT DATE = 4/25/2016	DRAWN - DCP	REVISED -
	CHECKED - JIG	REVISED -

**STATE OF ILLINOIS
DEPARTMENT OF TRANSPORTATION**

**TOP OF SLAB ELEVATIONS PLAN
STRUCTURE NO. 016-1703**

SHEET NO. S1-12 OF S1-53 SHEETS

F.A.I. R.E.	SECTION	COUNTY	TOTAL SHEETS	SHEET NO.
90/94/290	2014-004 R&B	COOK	706	197
CONTRACT NO. 60X78				
ILLINOIS FED. AID PROJECT				

GIRDER NO. 1

Location	Station	Offset	Theoretical Grade Elevations	Theoretical Grade Elevations Adjusted For Dead Load Deflection
Ⓞ Pier C1	5212+94.01	18.01	608.72	608.72
Ⓞ W. Brg. Pier C1	5212+95.03	18.05	608.70	608.70
A	5213+05.14	18.46	608.55	608.62
B	5213+15.24	18.80	608.40	608.52
C	5213+25.36	19.08	608.24	608.41
D	5213+35.47	19.30	608.08	608.27
E	5213+45.59	19.45	607.97	608.17
F	5213+55.71	19.55	607.85	608.05
G	5213+65.84	19.58	607.73	607.91
H	5213+75.96	19.55	607.61	607.75
I	5213+86.06	19.46	607.48	607.58
J	5213+96.06	19.34	607.34	607.40
K	5214+06.06	19.23	607.19	607.23
Ⓞ Brg. Pier 1	5214+18.56	19.08	607.00	607.00
L	5214+28.56	18.97	606.84	606.83
M	5214+38.56	18.85	606.66	606.67
N	5214+48.56	18.74	606.48	606.51
O	5214+58.56	18.62	606.29	606.34
P	5214+68.56	18.51	606.10	606.17
Q	5214+78.56	18.39	605.89	605.98
R	5214+88.55	18.28	605.68	605.77
S	5214+98.55	18.16	605.45	605.54
T	5215+08.55	18.05	605.22	605.30
U	5215+18.55	17.94	604.98	605.04
V	5215+28.55	17.82	604.74	604.77
W	5215+38.55	17.71	604.48	604.50
Ⓞ Brg. Pier 2	5215+50.55	17.57	604.16	604.16
X	5215+60.55	17.45	603.83	603.84
Y	5215+70.55	17.34	603.50	603.52
Z	5215+80.55	17.22	603.15	603.20
A1	5215+90.55	17.11	602.80	602.87
B1	5216+00.55	16.99	602.45	602.53
C1	5216+10.55	16.88	602.08	602.18
D1	5216+20.55	16.76	601.71	601.80
E1	5216+30.55	16.65	601.33	601.41
F1	5216+40.54	16.53	600.95	601.00
G1	5216+50.54	16.42	600.55	600.59
H1	5216+60.54	16.30	600.15	600.16
I1	5216+70.54	16.19	599.75	599.75
Ⓞ Brg. Pier 3	5216+82.54	16.05	599.31	599.31
J1	5216+92.54	15.94	598.93	598.95
K1	5217+02.51	15.83	598.54	598.59
L1	5217+12.41	15.76	598.15	598.24
M1	5217+22.32	15.76	597.75	597.88
N1	5217+32.22	15.81	597.35	597.52
O1	5217+42.13	15.93	596.95	597.14
P1	5217+52.03	16.11	596.52	596.72
Q1	5217+61.93	16.34	596.06	596.26
R1	5217+71.82	16.64	595.59	595.77
S1	5217+81.72	17.00	595.12	595.26
T1	5217+91.60	17.41	594.64	594.73
Ⓞ Brg. W. Abut. Bk. of W. Abut.	5218+03.96	18.02	594.04	594.04
	5218+06.45	18.15	593.92	593.92

GIRDER NO. 2

Location	Station	Offset	Theoretical Grade Elevations	Theoretical Grade Elevations Adjusted For Dead Load Deflection
Ⓞ Pier C1	5212+93.39	11.48	609.01	609.01
Ⓞ W. Brg. Pier C1	5212+94.41	11.52	609.00	609.00
A	5213+04.47	11.93	608.85	608.91
B	5213+14.54	12.27	608.70	608.82
C	5213+24.62	12.56	608.54	608.70
D	5213+34.69	12.78	608.38	608.57
E	5213+44.77	12.94	608.24	608.45
F	5213+54.85	13.04	608.11	608.31
G	5213+64.93	13.08	607.97	608.15
H	5213+75.01	13.05	607.83	607.97
I	5213+85.09	12.97	607.68	607.78
J	5213+95.09	12.85	607.52	607.59
K	5214+05.09	12.74	607.36	607.39
Ⓞ Brg. Pier 1	5214+17.59	12.59	607.14	607.14
L	5214+27.58	12.48	606.96	606.96
M	5214+37.58	12.36	606.77	606.78
N	5214+47.58	12.25	606.57	606.59
O	5214+57.58	12.14	606.36	606.41
P	5214+67.58	12.02	606.14	606.21
Q	5214+77.58	11.91	605.92	606.00
R	5214+87.58	11.79	605.69	605.78
S	5214+97.58	11.68	605.45	605.53
T	5215+07.58	11.56	605.20	605.27
U	5215+17.58	11.45	604.94	604.99
V	5215+27.58	11.33	604.67	604.71
W	5215+37.58	11.22	604.40	604.41
Ⓞ Brg. Pier 2	5215+49.58	11.08	604.06	604.06
X	5215+59.58	10.96	603.73	603.74
Y	5215+69.58	10.85	603.40	603.42
Z	5215+79.57	10.73	603.06	603.10
A1	5215+89.57	10.62	602.71	602.78
B1	5215+99.57	10.50	602.35	602.44
C1	5216+09.57	10.39	601.99	602.08
D1	5216+19.57	10.27	601.62	601.71
E1	5216+29.57	10.16	601.24	601.32
F1	5216+39.57	10.05	600.85	600.91
G1	5216+49.57	9.93	600.46	600.49
H1	5216+59.57	9.82	600.06	600.07
I1	5216+69.57	9.70	599.65	599.66
Ⓞ Brg. Pier 3	5216+81.57	9.56	599.19	599.19
J1	5216+91.57	9.45	598.79	598.81
K1	5217+01.55	9.33	598.38	598.44
L1	5217+11.50	9.26	597.97	598.06
M1	5217+21.44	9.25	597.56	597.68
N1	5217+31.38	9.31	597.13	597.30
O1	5217+41.33	9.42	596.71	596.90
P1	5217+51.27	9.59	596.27	596.47
Q1	5217+61.21	9.82	595.80	596.00
R1	5217+71.14	10.11	595.34	595.51
S1	5217+81.07	10.47	594.86	595.00
T1	5217+91.00	10.88	594.38	594.47
Ⓞ Brg. W. Abut. Bk. of W. Abut.	5218+03.40	11.48	593.78	593.78
	5218+05.90	11.62	593.66	593.66

GIRDER NO. 3

Location	Station	Offset	Theoretical Grade Elevations	Theoretical Grade Elevations Adjusted For Dead Load Deflection
Ⓞ Pier C1	5212+92.78	4.94	609.31	609.31
Ⓞ W. Brg. Pier C1	5212+93.80	4.99	609.29	609.29
A	5213+03.82	5.40	609.15	609.21
B	5213+13.85	5.75	608.99	609.11
C	5213+23.88	6.04	608.84	609.00
D	5213+33.91	6.26	608.68	608.87
E	5213+43.95	6.43	608.52	608.73
F	5213+53.99	6.53	608.37	608.57
G	5213+64.03	6.58	608.22	608.39
H	5213+74.07	6.56	608.05	608.19
I	5213+84.11	6.48	607.89	607.99
J	5213+94.11	6.36	607.71	607.77
K	5214+04.11	6.25	607.53	607.56
Ⓞ Brg. Pier 1	5214+16.61	6.11	607.29	607.29
L	5214+26.61	5.99	607.09	607.08
M	5214+36.61	5.88	606.88	606.88
N	5214+46.61	5.76	606.66	606.68
O	5214+56.61	5.65	606.43	606.48
P	5214+66.61	5.53	606.20	606.26
Q	5214+76.61	5.42	605.95	606.04
R	5214+86.61	5.30	605.70	605.79
S	5214+96.61	5.19	605.44	605.53
T	5215+06.61	5.07	605.17	605.25
U	5215+16.61	4.96	604.90	604.95
V	5215+26.60	4.84	604.61	604.65
W	5215+36.60	4.73	604.32	604.33
Ⓞ Brg. Pier 2	5215+48.60	4.59	603.96	603.96
X	5215+58.60	4.47	603.63	603.64
Y	5215+68.60	4.36	603.30	603.32
Z	5215+78.60	4.24	602.96	603.01
A1	5215+88.60	4.13	602.61	602.68
B1	5215+98.60	4.02	602.26	602.34
C1	5216+08.60	3.90	601.90	601.98
D1	5216+18.60	3.79	601.53	601.61
E1	5216+28.60	3.67	601.15	601.22
F1	5216+38.60	3.56	600.76	600.82
G1	5216+48.60	3.44	600.37	600.40
H1	5216+58.60	3.33	599.97	599.98
I1	5216+68.60	3.21	599.56	599.56
Ⓞ Brg. Pier 3	5216+80.59	3.07	599.07	599.07
J1	5216+90.59	2.96	598.65	598.67
K1	5217+00.59	2.84	598.23	598.28
L1	5217+10.57	2.77	597.80	597.89
M1	5217+20.56	2.75	597.36	597.49
N1	5217+30.54	2.80	596.92	597.08
O1	5217+40.52	2.91	596.47	596.66
P1	5217+50.50	3.07	596.02	596.22
Q1	5217+60.48	3.30	595.55	595.75
R1	5217+70.46	3.59	595.08	595.25
S1	5217+80.43	3.94	594.61	594.74
T1	5217+90.39	4.35	594.13	594.21
Ⓞ Brg. W. Abut. Bk. of W. Abut.	5218+02.84	4.95	593.52	593.52
	5218+05.36	5.08	593.40	593.40

0161703-60X78-5013-TSE.dgn



USER NAME = pateld	DESIGNED - JLP/HA	REVISED -
PLOT SCALE = N.T.S.	CHECKED - LFC	REVISED -
PLOT DATE = 3/23/2016	DRAWN - DCP	REVISED -
	CHECKED - JIG	REVISED -

**STATE OF ILLINOIS
DEPARTMENT OF TRANSPORTATION**

**TOP OF SLAB ELEVATIONS I
STRUCTURE NO. 016-1703**

SHEET NO. S1-13 OF S1-53 SHEETS

F.A.I. RTE.	SECTION	COUNTY	TOTAL SHEETS	SHEET NO.
90/94/290	2014-004 R&B	COOK	706	198
CONTRACT NO. 60X78				
ILLINOIS FED. AID PROJECT				

PROFILE GRADE LINE

Location	Station	Offset	Theoretical Grade Elevations	Theoretical Grade Elevations Adjusted For Dead Load Deflection
☉ Pier C1	5212+92.32	0.00	609.53	609.53
☉ W. Brg. Pier C1	5212+93.33	0.00	609.52	609.52
A	5213+03.28	0.00	609.39	609.45
B	5213+13.24	0.00	609.26	609.37
C	5213+23.20	0.00	609.11	609.27
D	5213+33.17	0.00	608.96	609.15
E	5213+43.15	0.00	608.80	609.01
F	5213+53.14	0.00	608.64	608.83
G	5213+63.13	0.00	608.47	608.64
H	5213+73.13	0.00	608.28	608.42
I	5213+83.14	0.00	608.09	608.20
J	5213+93.16	0.00	607.90	607.96
K	5214+03.18	0.00	607.69	607.73
☉ Brg. Pier 1	5214+15.70	0.00	607.43	607.43
L	5214+25.71	0.00	607.21	607.20
M	5214+35.73	0.00	606.98	606.98
N	5214+45.75	0.00	606.74	606.76
O	5214+55.76	0.00	606.50	606.54
P	5214+65.78	0.00	606.24	606.31
Q	5214+75.80	0.00	605.98	606.07
R	5214+85.81	0.00	605.72	605.81
S	5214+95.83	0.00	605.44	605.53
T	5215+05.85	0.00	605.16	605.23
U	5215+15.86	0.00	604.87	604.92
V	5215+25.88	0.00	604.57	604.60
W	5215+35.89	0.00	604.26	604.28
☉ Brg. Pier 2	5215+47.91	0.00	603.89	603.89
X	5215+57.93	0.00	603.57	603.57
Y	5215+67.95	0.00	603.24	603.26
Z	5215+77.96	0.00	602.90	602.94
A1	5215+87.98	0.00	602.55	602.62
B1	5215+98.00	0.00	602.20	602.28
C1	5216+08.01	0.00	601.84	601.93
D1	5216+18.03	0.00	601.47	601.56
E1	5216+28.05	0.00	601.09	601.17
F1	5216+38.06	0.00	600.71	600.77
G1	5216+48.08	0.00	600.32	600.35
H1	5216+58.10	0.00	599.92	599.94
I1	5216+68.11	0.00	599.51	599.52
☉ Brg. Pier 3	5216+80.13	0.00	599.02	599.02
J1	5216+90.15	0.00	598.59	598.61
K1	5217+00.17	0.00	598.16	598.21
L1	5217+10.18	0.00	597.72	597.81
M1	5217+20.18	0.00	597.28	597.40
N1	5217+30.17	0.00	596.83	596.99
O1	5217+40.16	0.00	596.37	596.55
P1	5217+50.14	0.00	595.90	596.10
Q1	5217+60.11	0.00	595.42	595.62
R1	5217+70.08	0.00	594.94	595.11
S1	5217+80.03	0.00	594.45	594.59
T1	5217+89.99	0.00	593.96	594.04
☉ Brg. W. Abut. Bk. of W. Abut.	5218+02.42	0.00	593.33	593.33
	5218+04.93	0.00	593.20	593.20

REFERENCE LINE

Location	Station	Offset	Theoretical Grade Elevations	Theoretical Grade Elevations Adjusted For Dead Load Deflection
☉ Pier C1	5212+92.32	0.00	609.53	609.53
☉ W. Brg. Pier C1	5212+93.33	0.05	609.52	609.52
A	5213+03.33	0.46	609.37	609.43
B	5213+13.32	0.81	609.22	609.34
C	5213+23.33	1.10	609.06	609.22
D	5213+33.33	1.34	608.90	609.09
E	5213+43.34	1.50	608.74	608.94
F	5213+53.35	1.61	608.57	608.77
G	5213+63.36	1.66	608.40	608.57
H	5213+73.37	1.65	608.23	608.37
I	5213+83.38	1.57	608.04	608.15
J	5213+93.38	1.45	607.85	607.92
K	5214+03.38	1.34	607.66	607.69
☉ Brg. Pier 1	5214+15.88	1.20	607.40	607.40
L	5214+25.87	1.08	607.18	607.18
M	5214+35.87	0.97	606.96	606.97
N	5214+45.87	0.85	606.73	606.75
O	5214+55.87	0.74	606.49	606.53
P	5214+65.87	0.62	606.24	606.30
Q	5214+75.87	0.51	605.98	606.06
R	5214+85.87	0.39	605.72	605.80
S	5214+95.87	0.28	605.44	605.53
T	5215+05.87	0.16	605.16	605.23
U	5215+15.87	0.05	604.87	604.92
V	5215+25.87	-0.07	604.57	604.60
W	5215+35.87	-0.18	604.26	604.28
☉ Brg. Pier 2	5215+47.87	-0.32	603.88	603.88
X	5215+57.87	-0.43	603.56	603.57
Y	5215+67.87	-0.55	603.23	603.25
Z	5215+77.86	-0.66	602.89	602.93
A1	5215+87.86	-0.78	602.54	602.61
B1	5215+97.86	-0.89	602.19	602.27
C1	5216+07.86	-1.01	601.82	601.91
D1	5216+17.86	-1.12	601.45	601.54
E1	5216+27.86	-1.24	601.08	601.15
F1	5216+37.86	-1.35	600.69	600.75
G1	5216+47.86	-1.47	600.30	600.33
H1	5216+57.86	-1.58	599.90	599.91
I1	5216+67.86	-1.70	599.49	599.49
☉ Brg. Pier 3	5216+79.86	-1.84	598.99	598.99
J1	5216+89.86	-1.95	598.55	598.57
K1	5216+99.86	-2.06	598.11	598.17
L1	5217+09.87	-2.15	597.67	597.76
M1	5217+19.88	-2.16	597.22	597.34
N1	5217+29.90	-2.12	596.76	596.92
O1	5217+39.91	-2.02	596.29	596.48
P1	5217+49.92	-1.86	595.83	596.03
Q1	5217+59.93	-1.63	595.36	595.55
R1	5217+69.93	-1.35	594.89	595.06
S1	5217+79.93	-1.00	594.41	594.55
T1	5217+89.93	-0.59	593.93	594.02
☉ Brg. W. Abut. Bk. of W. Abut.	5218+02.42	0.00	593.33	593.33
	5218+04.94	0.13	593.20	593.20

GIRDER NO. 4

Location	Station	Offset	Theoretical Grade Elevations	Theoretical Grade Elevations Adjusted For Dead Load Deflection
☉ Pier C1	5212+92.18	-1.59	609.60	609.60
☉ W. Brg. Pier C1	5212+93.18	-1.55	609.59	609.59
A	5213+03.17	-1.13	609.44	609.50
B	5213+13.16	-0.78	609.29	609.41
C	5213+23.15	-0.48	609.13	609.30
D	5213+33.14	-0.25	608.97	609.16
E	5213+43.14	-0.08	608.81	609.01
F	5213+53.14	0.03	608.64	608.83
G	5213+63.14	0.08	608.46	608.63
H	5213+73.14	0.06	608.28	608.42
I	5213+83.14	-0.01	608.10	608.20
J	5213+93.14	-0.13	607.90	607.96
K	5214+03.14	-0.24	607.70	607.73
☉ Brg. Pier 1	5214+15.64	-0.38	607.44	607.44
L	5214+25.64	-0.50	607.22	607.21
M	5214+35.64	-0.61	606.99	607.00
N	5214+45.64	-0.73	606.75	606.78
O	5214+55.64	-0.84	606.51	606.55
P	5214+65.63	-0.96	606.25	606.32
Q	5214+75.63	-1.07	605.99	606.07
R	5214+85.63	-1.19	605.72	605.81
S	5214+95.63	-1.30	605.44	605.53
T	5215+05.63	-1.42	605.15	605.23
U	5215+15.63	-1.53	604.86	604.91
V	5215+25.63	-1.65	604.56	604.59
W	5215+35.63	-1.76	604.24	604.26
☉ Brg. Pier 2	5215+47.63	-1.90	603.86	603.86
X	5215+57.63	-2.01	603.53	603.54
Y	5215+67.63	-2.13	603.20	603.23
Z	5215+77.63	-2.24	602.86	602.91
A1	5215+87.63	-2.36	602.52	602.58
B1	5215+97.63	-2.47	602.16	602.24
C1	5216+07.63	-2.59	601.80	601.89
D1	5216+17.62	-2.70	601.43	601.52
E1	5216+27.62	-2.82	601.05	601.13
F1	5216+37.62	-2.93	600.67	600.72
G1	5216+47.62	-3.05	600.28	600.31
H1	5216+57.62	-3.16	599.88	599.89
I1	5216+67.62	-3.28	599.47	599.47
☉ Brg. Pier 3	5216+79.62	-3.42	598.96	598.96
J1	5216+89.62	-3.53	598.52	598.54
K1	5216+99.62	-3.65	598.08	598.13
L1	5217+09.62	-3.73	597.63	597.71
M1	5217+19.67	-3.75	597.17	597.29
N1	5217+29.69	-3.71	596.71	596.87
O1	5217+39.71	-3.61	596.24	596.42
P1	5217+49.73	-3.44	595.77	595.96
Q1	5217+59.75	-3.22	595.30	595.49
R1	5217+69.76	-2.94	594.83	595.00
S1	5217+79.77	-2.59	594.35	594.49
T1	5217+89.78	-2.19	593.87	593.96
☉ Brg. W. Abut. Bk. of W. Abut.	5218+02.28	-1.59	593.26	593.26
	5218+04.80	-1.46	593.14	593.14

0161703-60X78-5014-TSE.dgn



USER NAME = pateld	DESIGNED - JLP/HA	REVISED -
	CHECKED - LFC	REVISED -
PLOT SCALE = N.T.S.	DRAWN - DCP	REVISED -
PLOT DATE = 3/23/2016	CHECKED - JIG	REVISED -

**STATE OF ILLINOIS
DEPARTMENT OF TRANSPORTATION**

**TOP OF SLAB ELEVATIONS II
STRUCTURE NO. 016-1703**

SHEET NO. S1-14 OF S1-53 SHEETS

F.A.I. RTE.	SECTION	COUNTY	TOTAL SHEETS	SHEET NO.
90/94/290	2014-004 R&B	COOK	706	199
CONTRACT NO. 60X78				
ILLINOIS FED. AID PROJECT				

STAGE CONSTRUCTION JOINT

Location	Station	Offset	Theoretical Grade Elevations	Theoretical Grade Elevations Adjusted For Dead Load Deflection
Ⓞ Pier C1	5212+91.97	-3.85	609.70	609.70
Ⓞ W. Brg. Pier C1	5212+92.97	-3.81	609.69	609.69
A	5213+02.94	-3.39	609.54	609.61
B	5213+12.92	-3.04	609.39	609.51
C	5213+22.90	-2.74	609.24	609.40
D	5213+32.88	-2.51	609.08	609.27
E	5213+42.86	-2.34	608.91	609.11
F	5213+52.85	-2.22	608.73	608.92
G	5213+62.83	-2.17	608.55	608.72
H	5213+72.82	-2.19	608.36	608.50
I	5213+82.81	-2.26	608.17	608.27
J	5213+92.80	-2.37	607.97	608.03
K	5214+02.80	-2.49	607.76	607.79
Ⓞ Brg. Pier 1	5214+15.30	-2.63	607.49	607.49
L	5214+25.30	-2.75	607.26	607.26
M	5214+35.30	-2.86	607.03	607.04
N	5214+45.30	-2.97	606.78	606.81
O	5214+55.30	-3.09	606.53	606.58
P	5214+65.30	-3.20	606.27	606.34
Q	5214+75.30	-3.32	606.00	606.09
R	5214+85.30	-3.43	605.73	605.82
S	5214+95.30	-3.55	605.44	605.53
T	5215+05.30	-3.66	605.15	605.22
U	5215+15.29	-3.78	604.85	604.90
V	5215+25.29	-3.89	604.54	604.57
W	5215+35.29	-4.01	604.22	604.23
Ⓞ Brg. Pier 2	5215+47.29	-4.15	603.83	603.83
X	5215+57.29	-4.26	603.50	603.51
Y	5215+67.29	-4.38	603.17	603.19
Z	5215+77.29	-4.49	602.83	602.88
A1	5215+87.29	-4.61	602.48	602.55
B1	5215+97.29	-4.72	602.13	602.21
C1	5216+07.29	-4.84	601.77	601.86
D1	5216+17.29	-4.95	601.40	601.49
E1	5216+27.29	-5.07	601.02	601.10
F1	5216+37.29	-5.18	600.64	600.69
G1	5216+47.29	-5.29	600.25	600.28
H1	5216+57.29	-5.41	599.85	599.86
I1	5216+67.28	-5.52	599.44	599.44
Ⓞ Brg. Pier 3	5216+79.28	-5.66	598.92	598.92
J1	5216+89.28	-5.78	598.48	598.50
K1	5216+99.28	-5.89	598.03	598.08
L1	5217+09.32	-5.98	597.57	597.66
M1	5217+19.36	-6.00	597.10	597.23
N1	5217+29.39	-5.96	596.63	596.80
O1	5217+39.43	-5.86	596.16	596.34
P1	5217+49.46	-5.70	595.68	595.88
Q1	5217+59.49	-5.48	595.21	595.41
R1	5217+69.52	-5.20	594.74	594.91
S1	5217+79.55	-4.85	594.26	594.40
T1	5217+89.57	-4.45	593.78	593.87
Ⓞ Brg. W. Abut. Bk. of W. Abut.	5218+02.08	-3.86	593.17	593.17
	5218+04.61	-3.72	593.05	593.05

GIRDER NO. 5

Location	Station	Offset	Theoretical Grade Elevations	Theoretical Grade Elevations Adjusted For Dead Load Deflection
Ⓞ Pier C1	5212+91.58	-8.13	609.90	609.90
Ⓞ W. Brg. Pier C1	5212+92.58	-8.08	609.88	609.88
A	5213+02.52	-7.66	609.74	609.80
B	5213+12.47	-7.30	609.59	609.71
C	5213+22.42	-7.01	609.43	609.59
D	5213+32.38	-6.77	609.27	609.46
E	5213+42.34	-6.59	609.09	609.30
F	5213+52.30	-6.48	608.91	609.10
G	5213+62.26	-6.43	608.71	608.88
H	5213+72.22	-6.43	608.51	608.65
I	5213+82.18	-6.50	608.31	608.41
J	5213+92.17	-6.62	608.10	608.16
K	5214+02.17	-6.73	607.88	607.91
Ⓞ Brg. Pier 1	5214+14.66	-6.87	607.59	607.59
L	5214+24.66	-6.99	607.35	607.35
M	5214+34.66	-7.10	607.10	607.11
N	5214+44.66	-7.22	606.85	606.87
O	5214+54.66	-7.33	606.58	606.63
P	5214+64.66	-7.45	606.31	606.38
Q	5214+74.66	-7.56	606.03	606.11
R	5214+84.66	-7.68	605.74	605.83
S	5214+94.66	-7.79	605.44	605.53
T	5215+04.66	-7.91	605.14	605.21
U	5215+14.66	-8.02	604.83	604.88
V	5215+24.66	-8.14	604.50	604.54
W	5215+34.66	-8.25	604.17	604.19
Ⓞ Brg. Pier 2	5215+46.66	-8.39	603.77	603.77
X	5215+56.66	-8.50	603.44	603.44
Y	5215+66.65	-8.62	603.11	603.13
Z	5215+76.65	-8.73	602.77	602.81
A1	5215+86.65	-8.85	602.42	602.49
B1	5215+96.65	-8.96	602.07	602.15
C1	5216+06.65	-9.08	601.71	601.79
D1	5216+16.65	-9.19	601.34	601.42
E1	5216+26.65	-9.31	600.96	601.04
F1	5216+36.65	-9.42	600.58	600.63
G1	5216+46.65	-9.54	600.19	600.22
H1	5216+56.65	-9.65	599.79	599.80
I1	5216+66.65	-9.77	599.38	599.38
Ⓞ Brg. Pier 3	5216+78.65	-9.91	598.85	598.85
J1	5216+88.65	-10.02	598.40	598.41
K1	5216+98.65	-10.13	597.93	597.98
L1	5217+08.70	-10.22	597.46	597.55
M1	5217+18.77	-10.25	596.98	597.11
N1	5217+28.83	-10.21	596.50	596.66
O1	5217+38.89	-10.12	596.01	596.19
P1	5217+48.95	-9.96	595.52	595.71
Q1	5217+59.01	-9.74	595.05	595.24
R1	5217+69.06	-9.46	594.58	594.75
S1	5217+79.12	-9.12	594.10	594.23
T1	5217+89.16	-8.72	593.61	593.70
Ⓞ Brg. W. Abut. Bk. of W. Abut.	5218+01.71	-8.13	593.01	593.01
	5218+04.25	-8.00	592.88	592.88

GIRDER NO. 6

Location	Station	Offset	Theoretical Grade Elevations	Theoretical Grade Elevations Adjusted For Dead Load Deflection
Ⓞ Pier C1	5212+90.98	-14.66	610.19	610.19
Ⓞ W. Brg. Pier C1	5212+91.98	-14.61	610.18	610.18
A	5213+01.88	-14.19	610.03	610.10
B	5213+11.79	-13.83	609.88	610.00
C	5213+21.70	-13.53	609.73	609.89
D	5213+31.62	-13.29	609.57	609.76
E	5213+41.54	-13.11	609.38	609.59
F	5213+51.46	-12.99	609.18	609.37
G	5213+61.38	-12.93	608.97	609.14
H	5213+71.30	-12.93	608.75	608.89
I	5213+81.22	-12.99	608.53	608.63
J	5213+91.19	-13.10	608.30	608.36
K	5214+01.19	-13.22	608.06	608.09
Ⓞ Brg. Pier 1	5214+13.69	-13.36	607.75	607.75
L	5214+23.69	-13.48	607.49	607.49
M	5214+33.69	-13.59	607.22	607.23
N	5214+43.69	-13.71	606.95	606.97
O	5214+53.69	-13.82	606.67	606.71
P	5214+63.69	-13.94	606.37	606.44
Q	5214+73.69	-14.05	606.08	606.16
R	5214+83.69	-14.17	605.77	605.86
S	5214+93.69	-14.28	605.45	605.54
T	5215+03.69	-14.40	605.13	605.20
U	5215+13.68	-14.51	604.80	604.85
V	5215+23.68	-14.63	604.45	604.49
W	5215+33.68	-14.74	604.11	604.12
Ⓞ Brg. Pier 2	5215+45.68	-14.88	603.68	603.68
X	5215+55.68	-14.99	603.34	603.35
Y	5215+65.68	-15.11	603.01	603.03
Z	5215+75.68	-15.22	602.67	602.72
A1	5215+85.68	-15.34	602.33	602.39
B1	5215+95.68	-15.45	601.97	602.05
C1	5216+05.68	-15.57	601.61	601.70
D1	5216+15.68	-15.68	601.24	601.33
E1	5216+25.68	-15.80	600.87	600.94
F1	5216+35.68	-15.91	600.48	600.54
G1	5216+45.68	-16.03	600.09	600.13
H1	5216+55.68	-16.14	599.70	599.71
I1	5216+65.67	-16.26	599.29	599.29
Ⓞ Brg. Pier 3	5216+77.67	-16.39	598.74	598.74
J1	5216+87.67	-16.51	598.27	598.29
K1	5216+97.67	-16.62	597.79	597.84
L1	5217+07.76	-16.72	597.30	597.39
M1	5217+17.86	-16.75	596.80	596.92
N1	5217+27.96	-16.72	596.29	596.46
O1	5217+38.07	-16.63	595.78	595.97
P1	5217+48.17	-16.48	595.27	595.47
Q1	5217+58.27	-16.26	594.80	594.99
R1	5217+68.36	-15.99	594.32	594.49
S1	5217+78.45	-15.65	593.84	593.98
T1	5217+88.54	-15.25	593.36	593.44
Ⓞ Brg. W. Abut. Bk. of W. Abut.	5218+01.14	-14.67	592.75	592.75
	5218+03.68	-14.54	592.62	592.62

0161703-60X78-5015-TSE.dgn



USER NAME = pateld	DESIGNED - JLP/HA	REVISED -
	CHECKED - LFC	REVISED -
PLOT SCALE = N.T.S.	DRAWN - DCP	REVISED -
PLOT DATE = 3/23/2016	CHECKED - JIG	REVISED -

STATE OF ILLINOIS
DEPARTMENT OF TRANSPORTATION

TOP OF SLAB ELEVATIONS III
STRUCTURE NO. 016-1703

SHEET NO. S1-15 OF S1-53 SHEETS

F.A.I. R.T.E.	SECTION	COUNTY	TOTAL SHEETS	SHEET NO.
90/94/290	2014-004 R&B	COOK	706	200
CONTRACT NO. 60X78				
ILLINOIS FED. AID PROJECT				